

ROBOTICS

Product manual

IRB 460



Trace back information:
Workspace 23D version a14
Checked in 2023-12-12
Skribenta version 5.5.019

Product manual
IRB 460 - 110/2.4
IRC5, OmniCore

Document ID: 3HAC039842-001
Revision: Y

The information in this manual is subject to change without notice and should not be construed as a commitment by ABB. ABB assumes no responsibility for any errors that may appear in this manual.

Except as may be expressly stated anywhere in this manual, nothing herein shall be construed as any kind of guarantee or warranty by ABB for losses, damage to persons or property, fitness for a specific purpose or the like.

In no event shall ABB be liable for incidental or consequential damages arising from use of this manual and products described herein.

This manual and parts thereof must not be reproduced or copied without ABB's written permission.

Keep for future reference.

Additional copies of this manual may be obtained from ABB.

Original instructions.

© Copyright 2012-2023 ABB. All rights reserved.
Specifications subject to change without notice.

Table of contents

Overview of this manual	9
Product documentation	15
How to read the product manual	17
1 Safety	19
1.1 Safety information	19
1.1.1 Limitation of liability	19
1.1.2 Requirements on personnel	20
1.2 Safety signals and symbols	21
1.2.1 Safety signals in the manual	21
1.2.2 Safety symbols on manipulator labels	23
1.3 Robot stopping functions	29
1.4 Safety during installation and commissioning	30
1.5 Safety during operation	33
1.6 Safety during maintenance and repair	34
1.6.1 Safety during maintenance and repair	34
1.6.2 Emergency release of the robot axes	37
1.6.3 Brake testing	38
1.7 Safety during troubleshooting	39
1.8 Safety during decommissioning	40
2 Installation and commissioning	41
2.1 Introduction to installation and commissioning	41
2.2 Unpacking	42
2.2.1 Pre-installation procedure	42
2.2.2 Technical data	43
2.2.3 Working range and type of motion	47
2.2.4 Risk of tipping/stability	49
2.2.5 The unit is sensitive to ESD	51
2.3 On-site installation	52
2.3.1 Lifting the robot with fork lift accessory	52
2.3.1.1 Fitting the fork lift accessory	52
2.3.1.2 Lifting the robot with fork lift truck	55
2.3.2 Lifting robot with roundslings	58
2.3.3 Manually releasing the brakes	60
2.3.4 Lifting the base plate	62
2.3.5 Securing the base plate	63
2.3.6 Orienting and securing the robot	68
2.3.7 Fitting equipment on robot	72
2.3.8 Loads fitted to the robot, stopping time and braking distances	76
2.4 Installation of options	77
2.4.1 Installation of cooling fan for axis-1 motor (Option 87-1)	77
2.4.2 Installation of signal lamp, upper arm (option), on IRC5 robots	83
2.4.3 Installation of signal lamp for OmniCore robots	87
2.5 Restricting the working range	88
2.5.1 Introduction	88
2.5.2 Mechanically restricting the working range of axis 1	89
2.6 Robot in cold environments	91
2.6.1 Start of robot in cold environments	91
2.7 Electrical connections	92
2.7.1 Robot cabling and connection points	92
2.7.2 Customer connectors on the manipulator	95
2.8 Test run after installation, maintenance, or repair	97
3 Maintenance	99
3.1 Introduction	99

Table of contents

3.2	Maintenance schedule and expected component life	100
3.2.1	Specification of maintenance intervals	100
3.2.2	Maintenance schedule	101
3.2.3	Expected component life	103
3.3	Inspection activities	104
3.3.1	Inspecting the oil level in axis-1 gearbox	104
3.3.2	Inspecting, oil level gearbox axes 2 - 3	106
3.3.3	Inspecting, oil level gearbox axis 6	109
3.3.4	Inspecting, cable harness	111
3.3.5	Inspecting the information labels	113
3.3.6	Inspecting the axis-1 mechanical stop pin	115
3.3.7	Inspecting the additional mechanical stops	117
3.3.8	Inspection, dampers	119
3.3.9	Inspecting the signal lamp (option)	121
3.4	Replacement/changing activities	123
3.4.1	Type of lubrication in gearboxes	123
3.4.2	Changing oil, axis-1 gearbox	124
3.4.3	Changing oil, gearbox axes 2 and 3	128
3.4.4	Changing oil, gearbox axis 6	132
3.4.5	Replacing the SMB battery	134
3.5	Cleaning activities	138
3.5.1	Cleaning the IRB 460	138
4	Repair	141
4.1	Introduction	141
4.2	General procedures	142
4.2.1	Performing a leak-down test	142
4.2.2	Mounting instructions for bearings	143
4.2.3	Mounting instructions for sealings	145
4.2.4	Cut the paint or surface on the robot before replacing parts	149
4.2.5	The brake release buttons may be jammed after service work	150
4.3	Complete robot	151
4.3.1	Replacing cable harness, lower end (axes 1-3)	151
4.3.2	Replacing the cable harness, upper end (incl. axis 6)	161
4.3.3	Replacing customer cable harness (optional)	168
4.3.4	Replacing the SMB unit	178
4.3.5	Replacing the brake release board	183
4.3.6	Replacing the base, including axis 1 gearbox	187
4.4	Upper and lower arm	196
4.4.1	Replacing the turning disk	196
4.4.2	Replacing the tilthouse unit	202
4.4.3	Replacing the upper arm	223
4.4.4	Replacing linkage - upper link arm	240
4.4.5	Replacing linkage - lower link arm	248
4.4.6	Replacing the linkage - link	255
4.4.7	Replacing the POM sealing for the link system	271
4.4.8	Replacing parallel rod	272
4.4.9	Replacing the complete lower arm system	283
4.4.10	Replacing the parallel arm	293
4.5	Motors	301
4.5.1	Replacing motor, axis 1	301
4.5.2	Replacing motors, axes 2 and 3	309
4.5.3	Replacing motor, axis 6	320
4.6	Gearboxes	328
4.6.1	Replacing the axis 1 gearbox	328
4.6.2	Replacing the axis 2 gearbox	337
4.6.3	Replacing the axis 3 gearbox	345
4.6.4	Replacing gearbox axis 6	352

5	Calibration	359
5.1	Introduction to calibration	359
5.1.1	Introduction and calibration terminology	359
5.1.2	Calibration methods	360
5.1.3	When to calibrate	361
5.2	Synchronization marks and axis movement directions	362
5.2.1	Synchronization marks and synchronization position for axes	362
5.2.2	Calibration movement directions for all axes	363
5.3	Updating revolution counters	364
5.3.1	Updating revolution counters on IRC5 robots	364
5.3.2	Updating revolution counters on OmniCore robots	368
5.4	Calibrating with Axis Calibration method	370
5.4.1	Description of Axis Calibration	370
5.4.2	Calibration tools for Axis Calibration	373
5.4.3	Installation locations for the calibration tools	375
5.4.4	Axis Calibration - Running the calibration procedure	377
5.4.5	Reference calibration	381
5.5	Verifying the calibration	383
5.6	Checking the synchronization position	384
6	Decommissioning	387
6.1	Introduction to decommissioning	387
6.2	Environmental information	388
6.3	Scrapping of robot	390
7	Reference information	391
7.1	Introduction	391
7.2	Applicable standards	392
7.3	Unit conversion	393
7.4	Screw joints	394
7.5	Weight specifications	397
7.6	Standard tools	398
7.7	Special tools	399
7.8	Lifting accessories and lifting instructions	402
8	Spare parts	403
8.1	Spare part lists and illustrations	403
9	Circuit diagrams	405
9.1	Circuit diagrams	405
	Index	407

This page is intentionally left blank

Overview of this manual

About this manual

This manual contains instructions for:

- mechanical and electrical installation of the IRB 460
- maintenance of the IRB 460
- mechanical and electrical repair of the IRB 460

The robot described in this manual has the following protection types:

- *Standard*

This manual describes the manipulator using either the IRC5 or the OmniCore controller.

Product manual scope

The manual covers all variants and designs of the IRB 460. Some variants and designs may have been removed from the business offer and are no longer available for purchase.

Usage

This manual should be used during:

- installation and commissioning, from lifting the product to its work site and securing it to the foundation, to making it ready for operation
- maintenance work
- repair work
- decommissioning work



Note

It is the responsibility of the integrator to conduct a risk assessment of the final application.

It is the responsibility of the integrator to provide safety and user guides for the robot system.

Who should read this manual?

This manual is intended for:

- installation personnel
 - maintenance personnel
 - repair personnel.
-

Prerequisites

A maintenance/repair/installation craftsman working with an ABB robot must:

- be trained by ABB and have the required knowledge of mechanical and electrical installation/repair/maintenance work.
 - be trained to respond to emergencies or abnormal situations.
-

Continues on next page

Overview of this manual

Continued

References

General

Document name	Document ID
<i>Product manual, spare parts - IRB 460</i>	3HAC040628-001
<i>Circuit diagram - IRB 460</i>	3HAC036446-005
<i>Technical reference manual - Lubrication in gearboxes</i>	3HAC042927-001
<i>Safety manual for robot - Manipulator and IRC5 or OmniCore controllerⁱ</i>	3HAC031045-001

ⁱ This manual contains all safety instructions from the product manuals for the manipulators and the controllers.

OmniCore robots

Document name	Document ID
<i>Product specification - IRB 460</i>	3HAC081954-001
<i>Product manual - OmniCore V250XT Type B</i>	3HAC087112-001
<i>Product manual - OmniCore V400XT</i>	3HAC081697-001
<i>Operating manual - OmniCore</i>	3HAC065036-001
<i>Technical reference manual - System parameters</i>	3HAC065041-001
<i>Application manual - Additional axes for OmniCore</i>	3HAC082287-001

IRC5 robots

Document name	Document ID
<i>Product specification - IRB 460</i>	3HAC039611-001
<i>Product manual - IRC5 IRC5 with main computer DSQC1000.</i>	3HAC047136-001
<i>Operating manual - IRC5 with FlexPendant</i>	3HAC050941-001
<i>Operating manual - Calibration Pendulum</i>	3HAC16578-1
<i>Operating manual - Service Information System</i>	3HAC050944-001
<i>Application manual - Additional axes and standalone controller</i>	3HAC051016-001
<i>Application manual - Electronic Position Switches</i>	3HAC050996-001
<i>Technical reference manual - System parameters</i>	3HAC050948-001

Revisions

Revision	Description
-	First edition.
A	This revision includes the following updates: <ul style="list-style-type: none">• Added safety section, <i>Signal lamp (optional)</i>.• A new block, about general illustrations, added in section How to read the product manual on page 17.• Illustrations improved throughout the Repair chapter.• Method of replacing the base updated and bits holder added in section Replacing the base, including axis 1 gearbox on page 187.• Refitting method updated in section Replacing the turning disk.

Continues on next page

Revision	Description
	<ul style="list-style-type: none"> • Re-calibration added in section Replacing the turning disk. • Details about tools added in section Replacing the tilthouse unit on page 202. • Procedures for Removal and Refitting updated in section Replacing the upper arm on page 223. • Three legged bearing puller added in Required equipment sections Replacing linkage - upper link arm on page 240 and Replacing linkage - lower link arm on page 248. • Replacing method updated in section Replacing motors, axes 2 and 3 on page 309. • Text updated in section Replacing the axis 1 gearbox on page 328. • In previous section Replacing the axis 2 and 3 gearboxes, replacing gearbox axis 3 has been removed and now only describes the axis 2 gearbox. • New section included Replacing the axis 3 gearbox. • Changed the weight of the robot, see Weight, robot on page 43. • Added an illustration that shows the directions of the robot stress forces, see Loads on foundation, robot on page 44. • Added new section about how to install the signal lamp, see Installation of signal lamp, upper arm (option), on IRC5 robots on page 83. • Added information that the working range of axis 1 also can be restricted by EPS, see Introduction on page 88. • Special tools updated.
B	<p>This revision includes the following updates:</p> <ul style="list-style-type: none"> • Minor corrections and editorial changes made throughout the manual. • Some general tightening torques have been changed/added, see updated values in Screw joints on page 394. • Added steps in the instruction for replacing upper end of cabling, see Replacing the cable harness, upper end (incl. axis 6) on page 161. • Added information about batteries.
C	<p>This revision includes the following updates:</p> <ul style="list-style-type: none"> • The maximum allowed deviation in levelness of the base plate is changed, see Securing the base plate on page 63. • Reference to Hilti standard added to the foundation recommendation for the base plate and class designation for foundation is changed to european standard C25/C30 (previously Swedish standard K25/K30), see Securing the base plate on page 63. • All data about type of lubrication in gearboxes is moved from the manual to a separate lubrication manual, see Type and amount of oil in gearboxes on page 123. • Added a new sealing structure that contains a support ring, o-ring and radial sealing at the link, see Replacing the linkage - link on page 255 and Replacing the upper arm on page 223. • Three o-rings are added to the equipment list and procedure in section Replacing the axis 1 gearbox on page 328. • A new SMB unit and battery is introduced, with longer battery lifetime.
D	<p>This revision includes the following updates:</p> <ul style="list-style-type: none"> • A new procedure is added to the manual: Installation of cooling fan for axis-1 motor (Option 87-1) on page 77. • The position of the battery holder for RMU lithium battery (3-pole battery contacts) has changed. The figures and text has been updated.
E	<p>This revision includes the following updates:</p> <ul style="list-style-type: none"> • Added information about risks when scrapping a decommissioned robot, see Scrapping of robot on page 390.

Continues on next page

Revision	Description
F	This revision includes the following updates: <ul style="list-style-type: none"> • New illustrations added for lower arm and lower and upper arm joints. • The maximum allowed deviation in levelness of the base plate and foundation is changed, see Securing the base plate on page 63. • Minor corrections.
G	This revision includes the following updates: <ul style="list-style-type: none"> • Splitted instruction for fork lift accessory use in two sections. • Illustrations of SMB battery RMU improved,
H	This revision includes the following updates: <ul style="list-style-type: none"> • Article number for label updated (Combined warning label "Brake release", "Brake release buttons" and "Moving robot")
J	Published in release R16.2. The following updates are made in this revision: <ul style="list-style-type: none"> • Drawing of base plate is not available for purchase, faulty information removed in Securing the base plate on page 63. • Corrections due to updates in terminology.
K	Published in release R17.1. The following updates are made in this revision: <ul style="list-style-type: none"> • Added labels to the robot, one warning label (A) on the axis-6 motor, one battery label (N) and one stock robots label (P) See Inspecting the information labels on page 113. • New standard calibration method is introduced (Axis Calibration). See Calibration on page 359.
L	Published in release R17.2. The following updates are made in this revision: <ul style="list-style-type: none"> • Caution about removing metal residues added in sections about SMB boards. • Information about minimum resonance frequency added. • Bending radius for static floor cables added. • Updated list of applicable standards. • Article number for the Calibration tool box, Axis Calibration is changed. • Added text regarding overhaul in section specification of maintenance intervals. • Updated the section Start of robot in cold environments on page 91. • Updated information regarding replacement of brake release board. • Lifting robot with roundslings updated. • Updated information regarding disconnecting and reconnecting battery cable to serial measurement board.
M	Published in release R18.1. The following updates are made in this revision: <ul style="list-style-type: none"> • Information added about fatigue to Axis Calibration tool, see Calibration tools for Axis Calibration on page 373. • Added section, Cut the paint or surface on the robot before replacing parts. • New spare part numbers brake release board. • Note added to calibration chapter to emphasize the requirement of equally dressed robot when using previously created reference calibration values. • Information about myABB Business Portal added.
N	Published in release R18.2. The following updates are done in this revision: <ul style="list-style-type: none"> • Added locating hole position in tool flange view.
P	Published in release R18.2. The following updates are done in this revision: <ul style="list-style-type: none"> • Updated references.
Q	Published in release 19B. The following updates are made in this revision: <ul style="list-style-type: none"> • New touch up color Graphite White available. See Cut the paint or surface on the robot before replacing parts on page 149.

Continues on next page

Revision	Description
	<ul style="list-style-type: none"> • New article numbers for manipulator cables in section Robot cabling and connection points on page 92. • Changed the article number of special tools bits extension and lifting accessory, motor axes 2-3 from 3HAC023760-001 and 3HAC14586-1 to 3HAC12342-1 and 3HAC15534-1, respectively. • Added tightening torque of the shaft when refitting the upper arm. • Updated the information of the hole for filling grease when refitting the link.
R	<p>Published in release 19D. The following updates are made in this revision:</p> <ul style="list-style-type: none"> • Added press tool for installation of support rings in the upper arm housing, see Replacing the upper arm on page 223.
S	<p>Published in release 20B. The following updates are made in this revision:</p> <ul style="list-style-type: none"> • Clarified and added information in mounting instructions for rotating sealings, see Mounting instructions for sealings on page 145. • Clarified text about position of robot axes during Axis Calibration. • Article number of Calibration tool box, Axis Calibration is changed from 3HAC062326-001 to 3HAC074119-001. • Replaced article number and name of grease, previously 3HAB3537-1.
T	<p>Published in release 21B. The following updates are made in this revision:</p> <ul style="list-style-type: none"> • New number and instruction for press tool, parallel arm, see Replacing the parallel arm on page 293. • New number and instruction for press tool, tilt house, see Replacing the tilthouse unit on page 202. • New number and instruction for press tool, linkage - link, see Replacing the linkage - link on page 255. • Text regarding fastener quality is updated, see Fastener quality on page 75.
U	<p>Published in release 21D. The following updates are made in this revision:</p> <ul style="list-style-type: none"> • New section regarding customer connectors added, see Customer connectors on the manipulator. • Added replacement of customer cable harness, see Replacing customer cable harness (optional) on page 168.
V	<p>Published in release 22B. The following updates are made in this revision:</p> <ul style="list-style-type: none"> • Controller OmniCore V250XT supported. • Updated information about Gleitmo treated screws, see Screw joints on page 394. • Updated the drawing of fitting extra equipment on upper arm. • Added the mounting/demounting tool (3HAC040021-001) to required equipment list for replacement of upper arm, complete lower arm system and axis-3 gearbox. • Added procedure of applying rust preventive when replacing axis-2 and axis-3 gearboxes.
W	<p>Published in release 23A. The following updates are done in this revision:</p> <ul style="list-style-type: none"> • Added a step for overall inspection of cabling after cable harness has been replaced. • Updated the part number for Taper roller bearing in section Replacing the tilthouse unit and the table for Required equipment.
X	<p>Published in release 23C. The following updates are done in this revision:</p> <ul style="list-style-type: none"> • Updated the tightening torque from 400 Nm to 800 Nm for securing the upper arm shaft.
Y	<p>Published in release 23D. The following updates are done in this revision:</p> <ul style="list-style-type: none"> • Added axis positions for most stable transport position and removed information about shipping position.

Continues on next page

Overview of this manual

Continued

Revision	Description
	<ul style="list-style-type: none"><li data-bbox="612 309 1070 338">• Added support for OmniCore V400XT.

Product documentation

Categories for user documentation from ABB Robotics

The user documentation from ABB Robotics is divided into a number of categories. This listing is based on the type of information in the documents, regardless of whether the products are standard or optional.



Tip

All documents can be found via myABB Business Portal, www.abb.com/myABB.

Product manuals

Manipulators, controllers, DressPack, and most other hardware is delivered with a **Product manual** that generally contains:

- Safety information.
- Installation and commissioning (descriptions of mechanical installation or electrical connections).
- Maintenance (descriptions of all required preventive maintenance procedures including intervals and expected life time of parts).
- Repair (descriptions of all recommended repair procedures including spare parts).
- Calibration.
- Troubleshooting.
- Decommissioning.
- Reference information (safety standards, unit conversions, screw joints, lists of tools).
- Spare parts list with corresponding figures (or references to separate spare parts lists).
- References to circuit diagrams.

Technical reference manuals

The technical reference manuals describe reference information for robotics products, for example lubrication, the RAPID language, and system parameters.

Application manuals

Specific applications (for example software or hardware options) are described in **Application manuals**. An application manual can describe one or several applications.

An application manual generally contains information about:

- The purpose of the application (what it does and when it is useful).
- What is included (for example cables, I/O boards, RAPID instructions, system parameters, software).
- How to install included or required hardware.
- How to use the application.

Continues on next page

- Examples of how to use the application.

Operating manuals

The operating manuals describe hands-on handling of the products. The manuals are aimed at those having first-hand operational contact with the product, that is production cell operators, programmers, and troubleshooters.

How to read the product manual

Reading the procedures

The procedures contain references to figures, tools, material, and so on. The references are read as described below.

References to figures

The procedures often include references to components or attachment points located on the manipulator/controller. The components or attachment points are marked with *italic text* in the procedures and completed with a reference to the figure where the current component or attachment point is shown.

The denomination in the procedure for the component or attachment point corresponds to the denomination in the referenced figure.

The table below shows an example of a reference to a figure from a step in a procedure.

	Action	Note/Illustration
8.	Remove the <i>rear attachment screws, gearbox</i> .	Shown in the figure Location of gearbox on page xx .

References to required equipment

The procedures often include references to equipment (spare parts, tools, etc.) required for the different actions in the procedure. The equipment is marked with *italic text* in the procedures and completed with a reference to the section where the equipment is listed with further information, that is article number and dimensions.

The designation in the procedure for the component or attachment point corresponds to the designation in the referenced list.

The table below shows an example of a reference to a list of required equipment from a step in a procedure.

	Action	Note/Illustration
3.	Fit a new <i>sealing, axis 2</i> to the gearbox.	Art. no. is specified in Required equipment on page xx .

Safety information

The manual includes a separate safety chapter that must be read through before proceeding with any service or installation procedures. All procedures also include specific safety information when dangerous steps are to be performed.

Read more in the chapter [Safety on page 19](#).

Illustrations

The robot is illustrated with general figures that does not take painting or protection type in consideration.

Likewise, certain work methods or general information that is valid for several robot models, can be illustrated with illustrations that show a different robot model than the one that is described in the current manual.

This page is intentionally left blank

1 Safety

1.1 Safety information

1.1.1 Limitation of liability

Limitation of liability

Any information given in this manual regarding safety must not be construed as a warranty by ABB that the industrial robot will not cause injury or damage even if all safety instructions are complied with.

The information does not cover how to design, install and operate a robot system, nor does it cover all peripheral equipment that can influence the safety of the robot system.

In particular, liability cannot be accepted if injury or damage has been caused for any of the following reasons:

- Use of the robot in other ways than intended.
- Incorrect operation or maintenance.
- Operation of the robot when the safety devices are defective, not in their intended location or in any other way not working.
- When instructions for operation and maintenance are not followed as intended.
- Non-authorized design modifications of the robot.
- Repairs on the robot and its spare parts carried out by in-experienced or non-qualified personnel.
- Foreign objects.
- Force majeure.

Spare parts and equipment

ABB supplies original spare parts and equipment which have been tested and approved for their intended use. The installation and/or use of non-original spare parts and equipment can negatively affect the safety, function, performance, and structural properties of the robot. ABB is not liable for damages caused by the use of non-original spare parts and equipment.

1 Safety

1.1.2 Requirements on personnel

1.1.2 Requirements on personnel

General

Only personnel with appropriate training are allowed to install, maintain, service, repair, and use the robot. This includes electrical, mechanical, hydraulics, pneumatics, and other hazards identified in the risk assessment.

Persons who are under the influence of alcohol, drugs or any other intoxicating substances are not allowed to install, maintain, service, repair, or use the robot.

The plant liable must make sure that the personnel is trained on the robot, and on responding to emergency or abnormal situations.

Personal protective equipment

Use personal protective equipment, as stated in the instructions.

1.2 Safety signals and symbols

1.2.1 Safety signals in the manual







Introduction to safety signals

This section specifies all safety signals used in the user manuals. Each signal consists of:

- A caption specifying the hazard level (DANGER, WARNING, or CAUTION) and the type of hazard.
- Instruction about how to reduce the hazard to an acceptable level.
- A brief description of remaining hazards, if not adequately reduced.

Hazard levels

The table below defines the captions specifying the hazard levels used throughout this manual.

Symbol	Designation	Significance
	DANGER	Signal word used to indicate an imminently hazardous situation which, if not avoided, will result in serious injury.
	WARNING	Signal word used to indicate a potentially hazardous situation which, if not avoided, could result in serious injury.
	ELECTRICAL SHOCK	Signal word used to indicate a potentially hazardous situation related to electrical hazards which, if not avoided, could result in serious injury.
	CAUTION	Signal word used to indicate a potentially hazardous situation which, if not avoided, could result in slight injury.
	ELECTROSTATIC DISCHARGE (ESD)	Signal word used to indicate a potentially hazardous situation which, if not avoided, could result in severe damage to the product.
	NOTE	Signal word used to indicate important facts and conditions.

Continues on next page

1 Safety

1.2.1 Safety signals in the manual

Continued

Symbol	Designation	Significance
	TIP	Signal word used to indicate where to find additional information or how to do an operation in an easier way.

1.2.2 Safety symbols on manipulator labels

Introduction to symbols

This section describes safety symbols used on labels (stickers) on the manipulator. Symbols are used in combinations on the labels, describing each specific warning. The descriptions in this section are generic, the labels can contain additional information such as values.



Note

The symbols on the labels on the product must be observed. Additional symbols added by the integrator must also be observed.



Types of symbols

Both the manipulator and the controller are marked with symbols, containing important information about the product. This is important for all personnel handling the robot, for example during installation, service, or operation.

The safety labels are language independent, they only use graphics. See [Symbols on safety labels on page 23](#).

The information labels can contain information in text.

Symbols on safety labels



Symbol	Description
 xx0900000812	Warning! Warns that an accident <i>may</i> occur if the instructions are not followed that can lead to serious injury, possibly fatal, and/or great damage to the product. It applies to warnings that apply to danger with, for example, contact with high voltage electrical units, explosion or fire risk, risk of poisonous gases, risk of crushing, impact, fall from height, etc.
 xx0900000811	Caution! Warns that an accident may occur if the instructions are not followed that can result in injury and/or damage to the product. It also applies to warnings of risks that include burns, eye injury, skin injury, hearing damage, crushing or slipping, tripping, impact, fall from height, etc. Furthermore, it applies to warnings that include function requirements when fitting and removing equipment where there is a risk of damaging the product or causing a breakdown.
 xx0900000839	Prohibition Used in combinations with other symbols.

Continues on next page

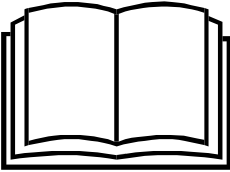
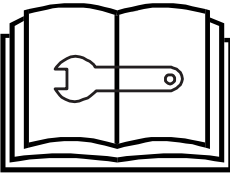
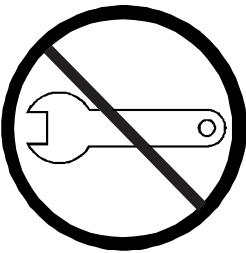
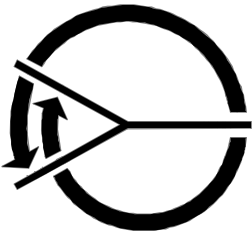

1 Safety

1.2.2 Safety symbols on manipulator labels

Continued

Symbol	Description
 xx0900000813	See user documentation Read user documentation for details. Which manual to read is defined by the symbol: <ul style="list-style-type: none">• No text: <i>Product manual</i>.• EPS: <i>Application manual - Electronic Position Switches</i>.
 xx0900000816	Before disassembly, see product manual
 xx0900000815	Do not disassemble Disassembling this part can cause injury.
 xx0900000814	Extended rotation This axis has extended rotation (working area) compared to standard.
 xx0900000808	Brake release Pressing this button will release the brakes. This means that the robot arm can fall down.

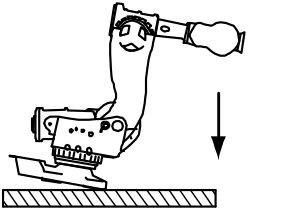

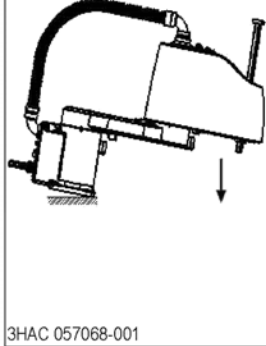
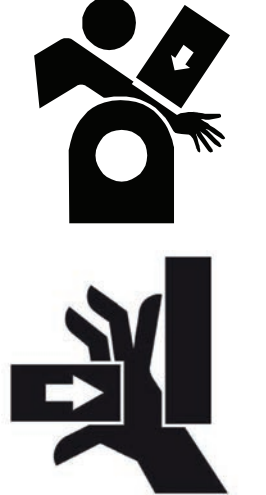
Continues on next page

Symbol	Description
 <p>xx0900000810</p>   <p>3HAC 057068-001</p> <p>xx1500002402</p>	<p>Tip risk when loosening bolts The robot can tip over if the bolts are not securely fastened.</p>
 <p>xx0900000817</p>	<p>Crush Risk of crush injuries.</p>





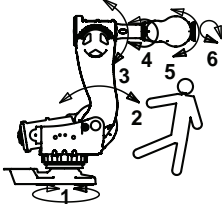
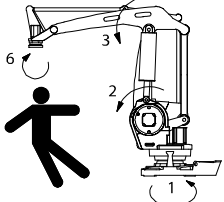
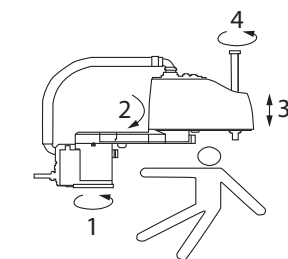

1 Safety

1.2.2 Safety symbols on manipulator labels

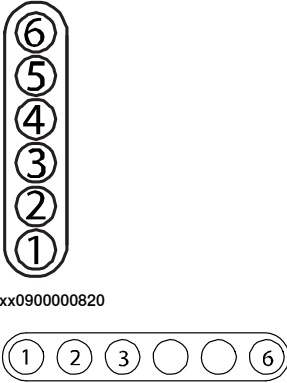
Continued

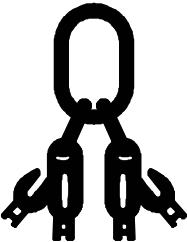
Symbol	Description
 xx0900000818  xx1300001087	Heat Risk of heat that can cause burns. (Both signs are used)
 xx0900000819  xx1000001141  xx1500002616	Moving robot The robot can move unexpectedly.

Continues on next page





Symbol	Description
 <p>xx0900000820</p> <p>xx1000001140</p>	<p>Brake release buttons</p>
 <p>xx0900000821</p>	<p>Lifting bolt</p>
 <p>xx1000001242</p>	<p>Adjustable chain sling with shortener</p>
 <p>xx0900000822</p>	<p>Lifting of robot</p>
 <p>xx0900000823</p>	<p>Oil Can be used in combination with prohibition if oil is not allowed.</p>
 <p>xx0900000824</p>	<p>Mechanical stop</p>

Continues on next page

1 Safety

1.2.2 Safety symbols on manipulator labels

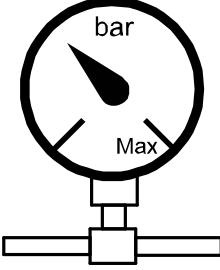
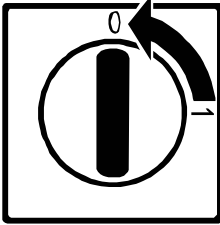
Continued

Symbol	Description
 xx1000001144	No mechanical stop
 xx0900000825	Stored energy Warns that this part contains stored energy. Used in combination with <i>Do not disassemble</i> symbol.
 xx0900000826	Pressure Warns that this part is pressurized. Usually contains additional text with the pressure level.
 xx0900000827	Shut off with handle Use the power switch on the controller.
 xx1400002648	Do not step Warns that stepping on these parts can cause damage to the parts.

1.3 Robot stopping functions

Protective stop and emergency stop

The protective stops and emergency stops are described in the product manual for the controller.

For more information see:

- *Product manual - OmniCore V250XT Type A*
- *Product manual - OmniCore V250XT Type B*
- *Product manual - OmniCore V400XT*
- *Product manual - IRC5*
- *Product manual - IRC5 Compact*
- *Product manual - IRC5 Panel Mounted Controller*

1 Safety

1.4 Safety during installation and commissioning

1.4 Safety during installation and commissioning

National or regional regulations

The integrator of the robot system is responsible for the safety of the robot system.

The integrator is responsible that the robot system is designed and installed in accordance with the safety requirements set forth in the applicable national and regional standards and regulations.

The integrator of the robot system is required to perform a risk assessment.

Layout

The robot integrated to a robot system shall be designed to allow safe access to all spaces during installation, operation, maintenance, and repair.

If robot movement can be initiated from an external control panel then an emergency stop must also be available.

If the manipulator is delivered with mechanical stops, these can be used for reducing the working space.

A perimeter safeguarding, for example a fence, shall be dimensioned to withstand the following:

- The force of the manipulator.
- The force of the load handled by the robot if dropped or released at maximum speed.
- The maximum possible impact caused by a breaking or malfunctioning rotating tool or other device fitted to the robot.

The maximum TCP speed and the maximum velocity of the robot axes are detailed in the section *Robot motion* in the product specification for the respective manipulator.

Consider exposure to hazards, such as slipping, tripping, and falling.

Hazards due to the working position and posture for a person working with or near the robot shall be considered.

Hazards due to noise emission from the robot needs to be considered.

Consider hazards from other equipment in the robot system, for example, that guards remain active until identified hazards are reduced to an acceptable level.

Allergenic material

See [Environmental information on page 388](#) for specification of allergenic materials in the product, if any.

Securing the robot to the foundation

The robot must be properly fixed to its foundation/support, as described in the respective product manual.

When the robot is installed at a height, hanging, or other than mounted directly on the floor, there will be additional hazards.

Continues on next page

Using lifting accessories and other external equipment

Ensure that all equipment used during installation, service and all handling of the robot are in correct condition for the intended use.

Electrical safety

Incoming mains must be installed to fulfill national regulations.

The power supply wiring to the robot must be sufficiently fused and if necessary, it must be possible to disconnect it manually from the mains power.

The power to the robot must be turned off with the main switch and the mains power disconnected when performing work inside the controller cabinet. Lock and tag shall be considered.

Harnesses between controller and manipulator shall be fixed and protected to avoid tripping and wear.

Wherever possible, power on/off or rebooting the robot controller shall be performed with all persons outside the safeguarded space.



Note

Use a CARBON DIOXIDE (CO₂) extinguisher in the event of a fire in the robot.

Safety devices

The integrator is responsible for that the safety devices necessary to protect people working with the robot system are designed and installed correctly.

When integrating the robot with external devices to a robot system:

- The integrator of the robot system must ensure that emergency stop functions are interlocked in accordance with applicable standards.
- The integrator of the robot system must ensure that safety functions are interlocked in accordance with applicable standards.

Other hazards

A robot may perform unexpected limited movement.



WARNING

Manipulator movements can cause serious injuries on users and may damage equipment.

The risk assessment should also consider other hazards arising from the application, such as, but not limited to:

- Water
- Compressed air
- Hydraulics

End-effector hazards require particular attention for applications which involve close human collaboration with the robot.

Continues on next page

1 Safety

1.4 Safety during installation and commissioning

Continued

Pneumatic or hydraulic related hazards



Note

The pressure in the complete pneumatic or hydraulic systems must be released before service and maintenance.

All components in the robot system that remain pressurized after switching off the power to the robot must be marked with clearly visible drain facilities and a warning sign that indicates the hazard of stored energy.

Loss of pressure in the robot system may cause parts or objects to drop.

Dump valves should be used in case of emergency.

Shot bolts should be used to prevent tools, etc., from falling due to gravity.

All pipes, hoses, and connections have to be inspected regularly for leaks and damage. Damage must be repaired immediately.

Verify the safety functions

Before the robot system is put into operation, verify that the safety functions are working as intended and that any remaining hazards identified in the risk assessment are mitigated to an acceptable level.

1.5 Safety during operation

Automatic operation

Verify the application in the operating mode manual reduced speed, before changing mode to automatic and initiating automatic operation.

Unexpected movement of robot arm



WARNING

Hazards due to the use of brake release devices and/or gravity beneath the manipulator shall be considered.

A robot may perform unexpected limited movement.



WARNING

Manipulator movements can cause serious injuries on users and may damage equipment.

1 Safety

1.6.1 Safety during maintenance and repair

1.6 Safety during maintenance and repair

1.6.1 Safety during maintenance and repair

General

Corrective maintenance must only be carried out by personnel trained on the robot. Maintenance or repair must be done with all electrical, pneumatic, and hydraulic power switched off, that is, no remaining hazards.

Hazards due to stored mechanical energy in the manipulator for the purpose of counterbalancing axes must be considered before maintenance or repair.

Never use the robot as a ladder, which means, do not climb on the controller, manipulator, including motors, or other parts. There are hazards of slipping and falling. The robot might be damaged.

Make sure that there are no tools, loose screws, turnings, or other unexpected parts remaining after maintenance or repair work.

When the work is completed, verify that the safety functions are working as intended.

Hot surfaces

Surfaces can be hot after running the robot, and touching these may result in burns. Allow the surfaces to cool down before maintenance or repair.

Allergic reaction

Warning	Description	Elimination/Action
 Allergic reaction	When working with lubricants there is a risk of an allergic reaction.	Make sure that protective gear like goggles and gloves are always worn.

Gearbox lubricants (oil or grease)

When handling oil, grease, or other chemical substances the safety information of the respective manufacturer must be observed.









Note

Take special care when handling hot lubricants.

Warning	Description	Elimination/Action
 Hot oil or grease	Changing and draining gearbox oil or grease may require handling hot lubricant heated up to 90 °C.	Make sure that protective gear like goggles and gloves are always worn during this activity.

Continues on next page

Warning	Description	Elimination/Action
 Allergic reaction	When working with lubricants there is a risk of an allergic reaction.	Make sure that protective gear like goggles and gloves are always worn.
 Possible pressure build-up in gearbox	When opening the oil or grease plug, there may be pressure present in the gearbox, causing lubricant to spray from the opening.	Open the plug carefully and keep away from the opening. Do not overfill the gearbox when filling.
 Do not overfill	Overfilling of gearbox lubricant can lead to internal over-pressure inside the gearbox which in turn may: <ul style="list-style-type: none"> • damage seals and gaskets • completely press out seals and gaskets • prevent the robot from moving freely. 	Make sure not to overfill the gearbox when filling it with oil or grease. After filling, verify that the level is correct.
 Do not mix types of oil	Mixing types of oil may cause severe damage to the gearbox.	When filling gearbox oil, do not mix different types of oil unless specified in the instructions. Always use the type of oil specified for the product.
 Oil residues	Oil residues might be present in a drained gearbox and spilled when separating a motor and gearbox during repair.	Make sure that protective gear like goggles/protective visor, gloves and arm protection are always worn during this activity. Put oil absorbent cloth or paper at appropriate locations to catch any oil residues.
 Heat up the oil	Warm oil drains quicker than cold oil.	Run the robot before changing the gearbox oil, if possible.
 Specified amount depends on drained volume	The specified amount of oil or grease is based on the total volume of the gearbox. When changing the lubricant, the amount refilled may differ from the specified amount, depending on how much has previously been drained from the gearbox.	After filling, verify that the level is correct.

Continues on next page

1 Safety

1.6.1 Safety during maintenance and repair

Continued

Warning	Description	Elimination/Action
 Contaminated oil in gearboxes	For lifetime reasons always drain as much oil as possible from the gearbox. The magnetic oil plugs will gather residual metal chips.	

Hazards related to batteries

Under rated conditions, the electrode materials and liquid electrolyte in the batteries are sealed and not exposed to the outside.

There is a hazard in case of abuse (mechanical, thermal, electrical) which leads to the activation of safety valves and/or the rupture of the battery container. As a result under certain circumstances, electrolyte leakage, electrode materials reaction with moisture/water or battery vent/explosion/fire may follow.

Do not short circuit, recharge, puncture, incinerate, crush, immerse, force discharge or expose to temperatures above the declared operating temperature range of the product. Risk of fire or explosion.

Operating temperatures are listed in [Operating conditions, robot on page 45](#).

See safety instructions for the batteries in *Material/product safety data sheet - Battery pack (3HAC043118-001)*.

Unexpected movement of robot arm



WARNING

Hazards due to the use of brake release devices and/or gravity beneath the manipulator shall be considered.

A robot may perform unexpected limited movement.



WARNING

Manipulator movements can cause serious injuries on users and may damage equipment.

Related information

See also the safety information related to installation and operation.

1.6.2 Emergency release of the robot axes

Description

In an emergency situation, the brakes on a robot axis can be released manually by pushing a brake release button.

How to release the brakes is described in the section:

- [Manually releasing the brakes on page 60](#).

The robot may be moved manually on smaller robot models, but larger models may require using an overhead crane or similar equipment.

Increased injury

Before releasing the brakes, make sure that the weight of the manipulator does not result in additional hazards, for example, even more severe injuries on a trapped person.



DANGER

When releasing the holding brakes, the robot axes may move very quickly and sometimes in unexpected ways.

Make sure no personnel is near or beneath the robot.

1 Safety

1.6.3 Brake testing

1.6.3 Brake testing

When to test

During operation, the holding brake of each axis normally wears down. A test can be performed to determine whether the brake can still perform its function.

How to test

The function of the holding brake of each axis motor may be verified as described below:

- 1 Run each axis to a position where the combined weight of the manipulator and any load is maximized (maximum static load).
- 2 Switch the motor to the MOTORS OFF.
- 3 Inspect and verify that the axis maintains its position.

If the manipulator does not change position as the motors are switched off, then the brake function is adequate.



Note

It is recommended to run the service routine *BrakeCheck* as part of the regular maintenance, see the operating manual for the robot controller.

For robots with the option SafeMove, the *Cyclic Brake Check* routine is recommended. See the manual for SafeMove in [References on page 10](#).

1.7 Safety during troubleshooting

General

When troubleshooting requires work with power switched on, special considerations must be taken:

- Safety circuits might be muted or disconnected.
- Electrical parts must be considered as *live*.
- The manipulator can move unexpectedly at any time.



DANGER

Troubleshooting on the controller while powered on must be performed by personnel trained by ABB or by ABB field engineers.

A risk assessment must be done to address both robot and robot system specific hazards.



WARNING

Hazards due to the use of brake release devices and/or gravity beneath the manipulator shall be considered.

A robot may perform unexpected limited movement.



WARNING

Manipulator movements can cause serious injuries on users and may damage equipment.

Related information

See also the safety information related to installation, operation, maintenance, and repair.

1 Safety

1.8 Safety during decommissioning

1.8 Safety during decommissioning

General

See section [Decommissioning on page 387](#).

If the robot is decommissioned for storage, take extra precaution to reset safety devices to delivery status.

Unexpected movement of robot arm



WARNING

Hazards due to the use of brake release devices and/or gravity beneath the manipulator shall be considered.

A robot may perform unexpected limited movement.



WARNING

Manipulator movements can cause serious injuries on users and may damage equipment.

2 Installation and commissioning

2.1 Introduction to installation and commissioning

General

This chapter contains assembly instructions and information for installing the IRB 460 at the working site.

See also the product manual for the robot controller.

The installation must be done by qualified installation personnel in accordance with the safety requirements set forth in the applicable national and regional standards and regulations.

The technical data is detailed in section [Technical data on page 43](#).

Safety information

Before any installation work is commenced, all safety information must be observed. There are general safety aspects that must be read through, as well as more specific safety information that describes the danger and safety risks when performing the procedures. Read the chapter [Safety on page 19](#) before performing any installation work.



Note

Always connect the IRB 460 and the robot to protective earth and residual current device (RCD) before connecting to power and starting any installation work.

For more information see:

- *Product manual - OmniCore V250XT Type A*
- *Product manual - OmniCore V250XT Type B*
- *Product manual - OmniCore V400XT*
- *Product manual - IRC5*
- *Product manual - IRC5 Compact*
- *Product manual - IRC5 Panel Mounted Controller*

2 Installation and commissioning

2.2.1 Pre-installation procedure

2.2 Unpacking

2.2.1 Pre-installation procedure

Introduction

This section is intended for use when unpacking and installing the robot for the first time. It also contains information useful during later re-installation of the robot.

Prerequisites for installation personnel

Installation personnel working with an ABB product must:

- be trained by ABB and have the required knowledge of mechanical and electrical installation/maintenance/repair work
- conform to all national and local codes.

Checking the pre-requisites for installation

	Action
1	Make a visual inspection of the packaging and make sure that nothing is damaged.
2	Remove the packaging.
3	Check for any visible transport damage.  Note Stop unpacking and contact ABB if transport damages are found.
4	Clean the unit with a lint-free cloth, if necessary.
5	Make sure that the lifting accessory used (if required) is suitable to handle the weight of the robot as specified in: Weight, robot on page 43
6	If the robot is not installed directly, it must be stored as described in: Storage conditions, robot on page 45
7	Make sure that the expected operating environment of the robot conforms to the specifications as described in: Operating conditions, robot on page 45
8	Before taking the robot to its installation site, make sure that the site conforms to: <ul style="list-style-type: none">• Loads on foundation, robot on page 44• Protection classes, robot on page 46• Requirements, foundation on page 45
9	Before moving the robot, please observe the stability of the robot: Risk of tipping/stability on page 49
10	When these prerequisites are met, the robot can be taken to its installation site as described in section: On-site installation on page 52
11	Install required equipment, if any. <ul style="list-style-type: none">• Installation of signal lamp, upper arm (option), on IRC5 robots on page 83• Installation of cooling fan for axis-1 motor (Option 87-1) on page 77

2.2.2 Technical data

Weight, robot

The table shows the weight of the robot.

Robot model	Weight
IRB 460	925 kg



Note

The weight does not include tools and other equipment fitted on the robot.

Mounting positions

The table shows valid mounting options for the manipulator.

Mounting option	Installation angle	Note
Floor mounted	0°	



Note

The actual mounting angle must always be configured in the system parameters, otherwise the performance and lifetime is affected.

Continues on next page

2 Installation and commissioning

2.2.2 Technical data

Continued

Loads on foundation, robot

The illustration shows the directions of the robots stress forces.

The directions are valid for all floor mounted, suspended and inverted robots.

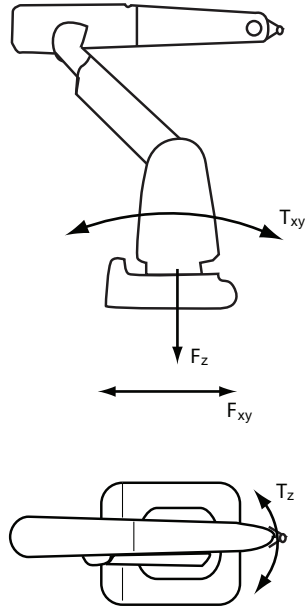

xx1100000521

F_{xy}	Force in any direction in the XY plane
F_z	Force in the Z plane
T_{xy}	Bending torque in any direction in the XY plane
T_z	Bending torque in the Z plane

The table shows the various forces and torques working on the robot during different kinds of operation.



Note

These forces and torques are extreme values that are rarely encountered during operation. The values also never reach their maximum at the same time!



WARNING

The robot installation is restricted to the mounting options given in following load table(s).

Floor mounted

Force	Endurance load (in operation)	Max. load (emergency stop)
Force xy	± 6.2 kN	± 10.6 kN
Force z	10 ± 3.8 kN	10 ± 6.5 kN
Torque xy	± 13.7 kNm	± 23 kNm
Torque z	± 5.3 kNm	± 7.9 kNm

Continues on next page

Requirements, foundation

The table shows the requirements for the foundation where the weight of the installed robot is included:

Requirement	Value	Note
Flatness of foundation surface	0.3 mm	Flat foundations give better repeatability of the resolver calibration compared to original settings on delivery from ABB. The value for levelness aims at the circumstance of the anchoring points in the robot base.
Minimum resonance frequency	20 Hz  Note It may affect the manipulator life-time to have a lower resonance frequency than recommended.	The value is recommended for optimal performance. Due to foundation stiffness, consider robot mass including equipment. ⁱ For information about compensating for foundation flexibility, see the application manual of the controller software, section <i>Motion Process Mode</i> .

ⁱ The minimum resonance frequency given should be interpreted as the frequency of the robot mass/inertia, robot assumed stiff, when a foundation translational/torsional elasticity is added, i.e., the stiffness of the pedestal where the robot is mounted. The minimum resonance frequency should not be interpreted as the resonance frequency of the building, floor etc. For example, if the equivalent mass of the floor is very high, it will not affect robot movement, even if the frequency is well below the stated frequency. The robot should be mounted as rigid as possible to the floor.

Disturbances from other machinery will affect the robot and the tool accuracy. The robot has resonance frequencies in the region 10 – 20 Hz and disturbances in this region will be amplified, although somewhat damped by the servo control. This might be a problem, depending on the requirements from the applications. If this is a problem, the robot needs to be isolated from the environment.

Storage conditions, robot

The table shows the allowed storage conditions for the robot:

Parameter	Value
Minimum ambient temperature	-25° C
Maximum ambient temperature	+55° C
Maximum ambient temperature (less than 24 hrs)	+70° C
Maximum ambient humidity	95% at constant temperature (gaseous only)

Operating conditions, robot

The table shows the allowed operating conditions for the robot:

Parameter	Value
Minimum ambient temperature	0° C ⁱ
Maximum ambient temperature	+45° C
Maximum ambient humidity	95% at constant temperature

ⁱ During cold start (0° C - 5° C), see [Start of robot in cold environments on page 91](#).

Continues on next page

2 Installation and commissioning

2.2.2 Technical data

Continued

Protection classes, robot

The table shows the available protection types of the robot, with the corresponding protection class.

Protection type	Protection class ⁱ
Manipulator, protection type Standard	IP 67

ⁱ According to IEC 60529.

2.2.3 Working range and type of motion

Working range

The following figures show the working ranges of the robot variants. The extreme positions of the robot arm are specified at the wrist center (dimensions in mm).

IRB 460 - 110/2.4

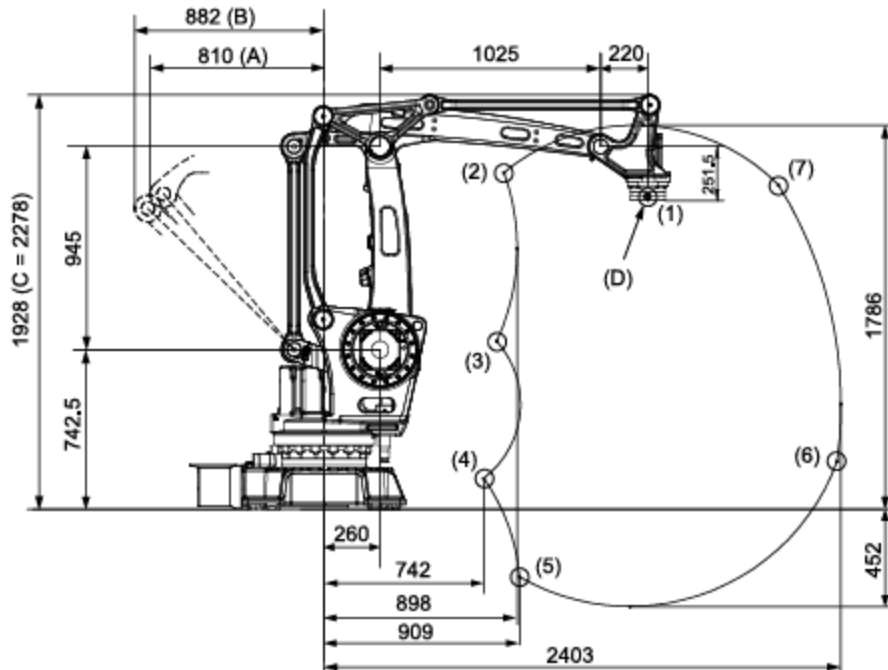

xx1000001043

A	Maximal working range
B	Mechanical stop
C	Maximal working range
D	Tool flange center

Position in figure	Position (mm)		Angles (°)	
	X	Z	Axis 2	Axis 3
1	1505	1437	0	0
2	836	1565	-40	-20
3	802	782	-40	25
4	742	145	55	120
5	909	-314	85	120
6	2385	223	85	20
7	2111	1510	45	-20

Continues on next page

2 Installation and commissioning

2.2.3 Working range and type of motion

Continued

Type of motion

The table below specifies the types and ranges of the robot motion in every axis.

Axis	Type of motion	Range of motion
1	Rotation motion	-165° to +165°
2	Arm motion	-40° to +85°
3	Arm motion	-20° to +120°
2-3	Arm motion	25° to 155°
6	Turn motion	-300° to +300°

Turning radius

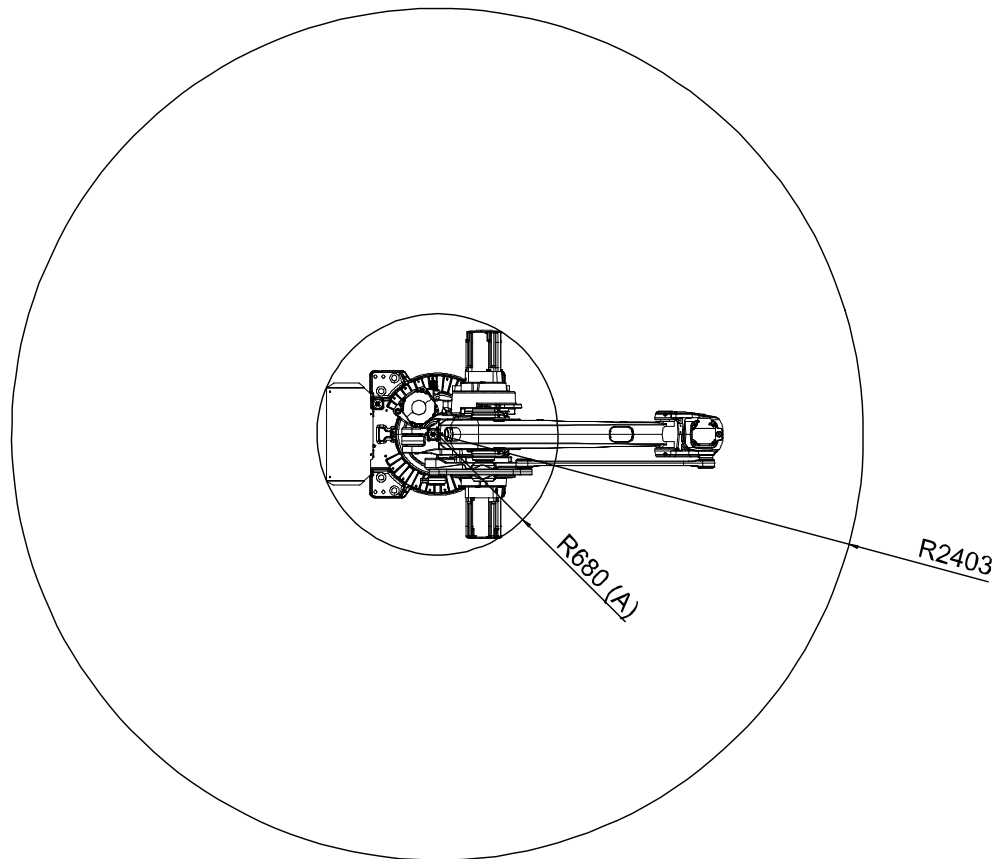

xx1000001202

(A)	Motor, axis 3
-----	---------------

2.2.4 Risk of tipping/stability

Risk of tipping

If the robot is not fastened to the foundation while moving the arm, the robot is not stable in the whole working area. Moving the arm will displace the center of gravity, which may cause the robot to tip over.

The transportation position is the most stable position.

Do not change the robot position before securing it to the foundation!

Transportation position

This figure shows the robot in its transportation position.

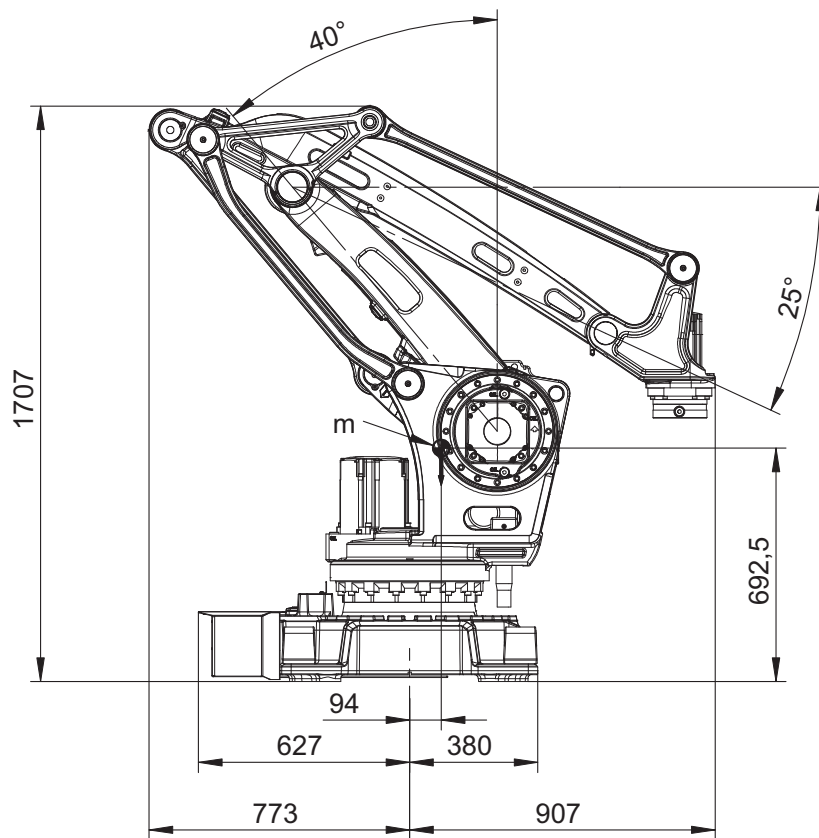

xx1000001158

Axis number	Angle of axis
Axis 1	0°
Axis 2	-40°
Axis 3	+25°
Axis 4	0°
Axis 5	+0°
Axis 6	0°

Continues on next page

2 Installation and commissioning

2.2.4 Risk of tipping/stability

Continued



Note

The robot might be positioned in a different position at delivery, due to actual configurations and options (for example DressPack).



WARNING

The robot will be mechanically unstable if not properly secured to the foundation.

2.2.5 The unit is sensitive to ESD

Description

ESD (electrostatic discharge) is the transfer of electrical static charge between two bodies at different potentials, either through direct contact or through an induced electrical field. When handling parts or their containers, personnel not grounded may potentially transfer high static charges. This discharge may destroy sensitive electronics.

Safe handling

Use one of the following alternatives:

- Use a wrist strap.

Wrist straps must be tested frequently to ensure that they are not damaged and are operating correctly.

- Use an ESD protective floor mat.

The mat must be grounded through a current-limiting resistor.

- Use a dissipative table mat.

The mat should provide a controlled discharge of static voltages and must be grounded.

2 Installation and commissioning

2.3.1.1 Fitting the fork lift accessory

2.3 On-site installation

2.3.1 Lifting the robot with fork lift accessory



2.3.1.1 Fitting the fork lift accessory

Required equipment

The following equipment is required when lifting a robot with the fork lift accessory:

Equipment	Art. no.	Note
Fork lift pocket set	3HAC025040-003	The fork lift accessory set contains: <ul style="list-style-type: none"> • fork lift pocket 3HAC025528-001, with CE-Marking fitted (4 pcs) • attachment screws M20x60 Steel 8.8-A3F (8 pcs) • Drawing Fork lift accessory set • manual <i>Directions for use - Fork lift accessory for IRB 6620, 6640, 460</i>
Fork lift truck	-	The operator must be fully trained and authorized to operate a fork lift truck.

Preparations before fitting the fork lift pockets

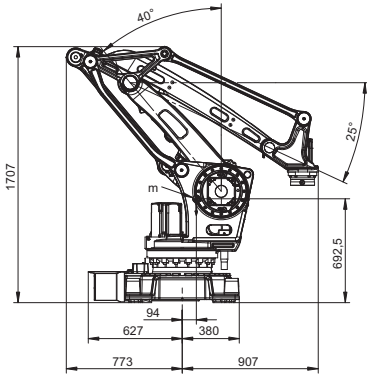
	Action	Note
1	<p>Remove any tools fitted on the axis-6 turning disk.</p> <p> Note</p> <p>No tool is permitted to be fitted on the robot when lifting the robot with the fork lift accessory!</p>	<p>DressPack, if used, can stay fitted as long as the tool fitted on the turning disk is removed.</p>
2	<p>Jog the robot to its shipping position. See figures for the different IRB models.</p> <p> Note</p> <p>The figures shows the shipping position of an <i>undressed</i> robot. If the robot is dressed, this must be taken into consideration when the robot is being lifted.</p>	 <p>xx1000001158</p>

Continues on next page

	Action	Note
3	<p> DANGER</p> <p>Turn off all:</p> <ul style="list-style-type: none">• electric power supply• hydraulic pressure supply• air pressure supply <p>to the robot, before entering the robot working area.</p>	

Attachment points on the robot

The fork lift accessory is fitted on the robot as shown in the figure.

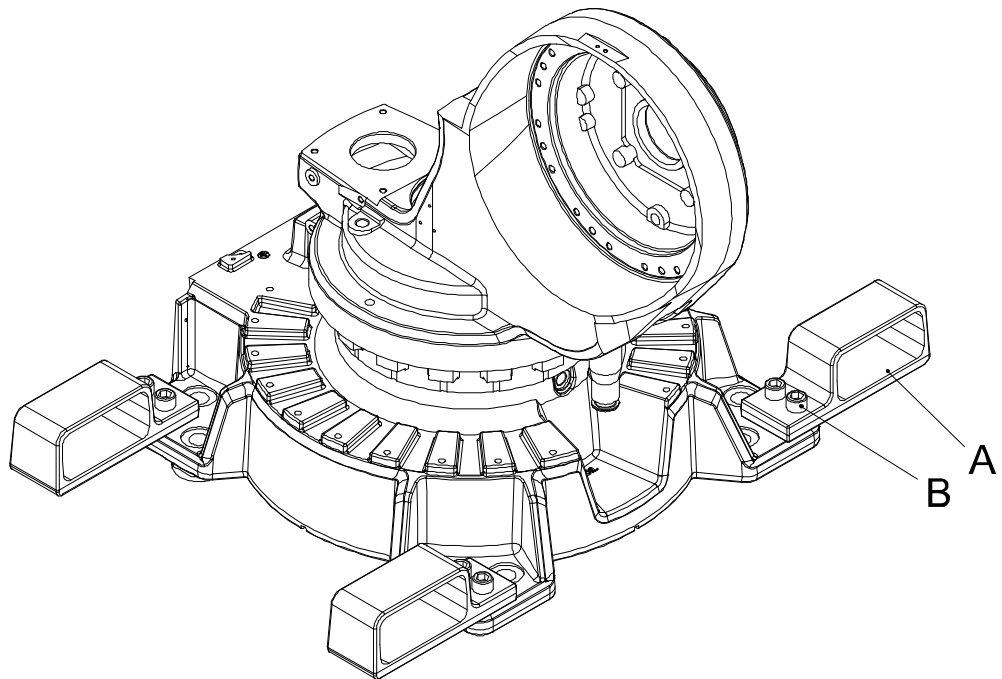

xx0600002910

A	Fork lift pocket
B	Attachment screw M20x60 quality 8.8 (2 pcs x4)

Continues on next page

2 Installation and commissioning

2.3.1.1 Fitting the fork lift accessory

Continued

Fitting the fork lift accessory set

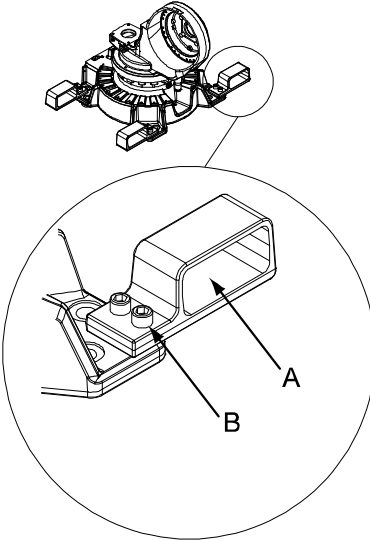
	Action	Note
1	<p>Fit the four fork lift pockets on the base of the robot with its attachment screws.</p> <p> Note</p> <p>Before fitting any attachment screws, make sure they are not damaged in any way. Replace damaged screws.</p>	<p>Tightening torque: 300 Nm</p>  <p>xx0600002930</p> <p>A Fork lift pocket (4 pcs) B Attachment screw M20x60 quality 8.8 (2 pcs x4)</p>
2	<p>Verify that all four fork lift pockets are properly secured before lifting.</p>	

2.3.1.2 Lifting the robot with fork lift truck

General



The robot may be moved using a fork lift truck, provided that a complete fork lift accessory set, aimed for the robot, is used.

This section describes how to lift the robot with a fork lift truck.

Required equipment

Equipment	Art. no.	Note
Fork lift accessory	3HAC025040-003	
Fork lift truck		

Lifting the robot with fork lift truck

	Action	Note
1	Make sure that the robot is in shipping position!	 Note No load is permitted on the robot!
2	 DANGER Make sure that all supplies for electrical power, hydraulic pressure, and air pressure are turned off.	
3	Verify that all four fork lift pockets are properly secured before lifting.	

Continues on next page

2 Installation and commissioning

2.3.1.2 Lifting the robot with fork lift truck

Continued

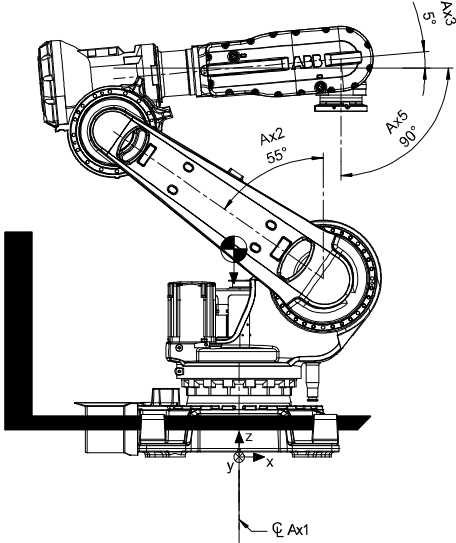
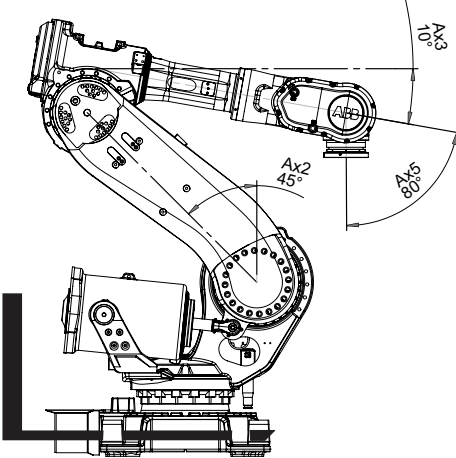
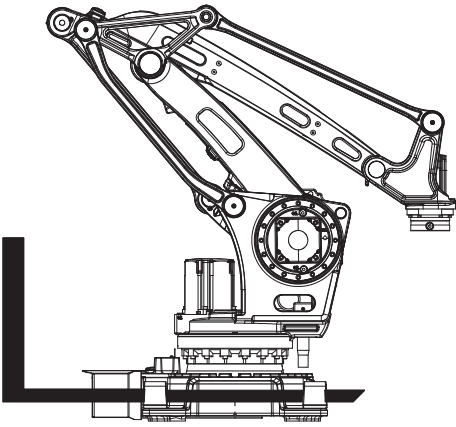



	Action	Note
4	<p>Insert fork lift forks into the pockets.</p> <p> CAUTION</p> <p>Lifting the robot with fork lift shall only be done with all four fork lift pockets fitted! If lifting with fewer than four fork lift pockets fitted, there is a risk of accidents!</p>	<p>IRB 6620</p>  <p>xx0600002911</p> <p>IRB 6640</p>  <p>xx0600003401</p> <p>IRB 460</p>  <p>xx1000001159</p>

Continues on next page

2 Installation and commissioning

2.3.1.2 Lifting the robot with fork lift truck

Continued

	Action	Note
5	Remove the attachment bolts securing the robot to the foundation.	
6	 CAUTION The IRB 460 robot weighs 925 kg. All lifting accessories used must be sized accordingly!	
7	Carefully lift the robot.  WARNING Personnel must not, under any circumstances, be present under the suspended load!	
8	Move the robot slowly to its new position.	 Note Move the robot with low speed!
9	Secure the robot to the foundation  DANGER Do not power the robot up until it is secured properly to the foundation.	
10	Remove the fork lift accessories.	

2 Installation and commissioning

2.3.2 Lifting robot with roundslings

2.3.2 Lifting robot with roundslings





General

The robot can be lifted with roundslings according to this section.

Sling specification

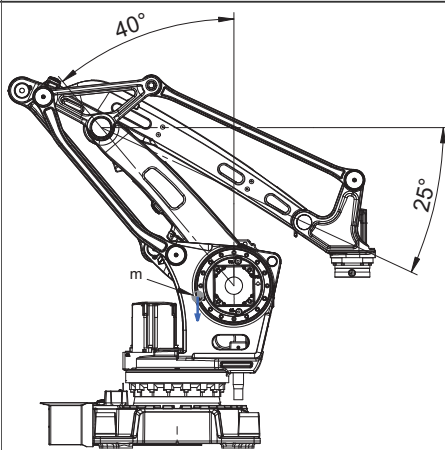
Sling type	Qty	Lifting capacity	Length / Note
Roundslings, robot	3 pcs	2 000 kg	2 m
	2 pcs	2 000 kg	2.5 m

Lifting with roundslings

	Action	Note
1	Position robot in a secure transport position.	 <p>xx1000001155</p>
2	Attach <i>lifting eye bolts</i> in the rear M20 holes.	Shown in figure Attachment points on page 59 .
3	Attach roundslings to robot according to figure Attachment points on page 59 .	
4	 Note Make sure that the roundslings do not lie against sensitive parts, for example harness and customer equipment!	
5	 CAUTION The IRB 460 robot weighs 925 kg. All lifting accessories used must be sized accordingly!	
6	 WARNING Personnel must not, under any circumstances, be present under the suspended load!	

Continues on next page

Attachment points

This figure shows how to attach the roundslings to the robot.

The illustration is similar with the label attached to the robot's lower arm.

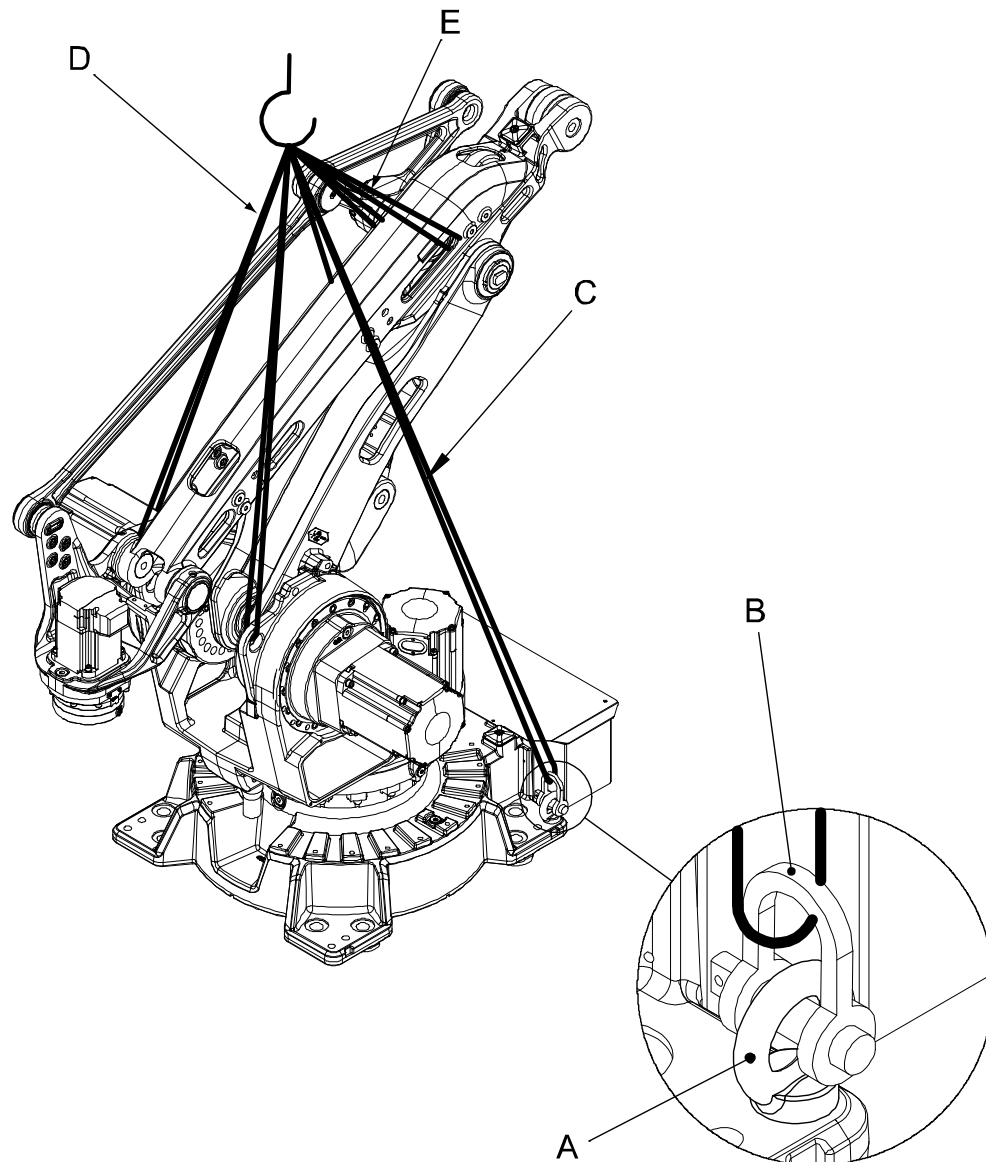

xx1000001156

A	Lifting eye bolts M20 (2 pcs)
B	Shackle (2 pcs). Lifting capacity: 2,000 kg.
C	Roundsling, 2 m (2 pcs). Lifting capacity: 2,000 kg.
D	Roundsling, 2.5 m (2 pcs). Lifting capacity: 2,000 kg. Wrap once!
E	Roundsling, 2 m, secures against rotation. Lifting capacity: 2,000 kg. Wrap twice!

2 Installation and commissioning

2.3.3 Manually releasing the brakes

2.3.3 Manually releasing the brakes

Introduction to manually releasing the brakes

This section describes how to release the holding brakes for the motors of each axis.

Location of brake release unit

The internal brake release unit is located as shown in the figure.



Note

Axes 4 and 5 do not exist!

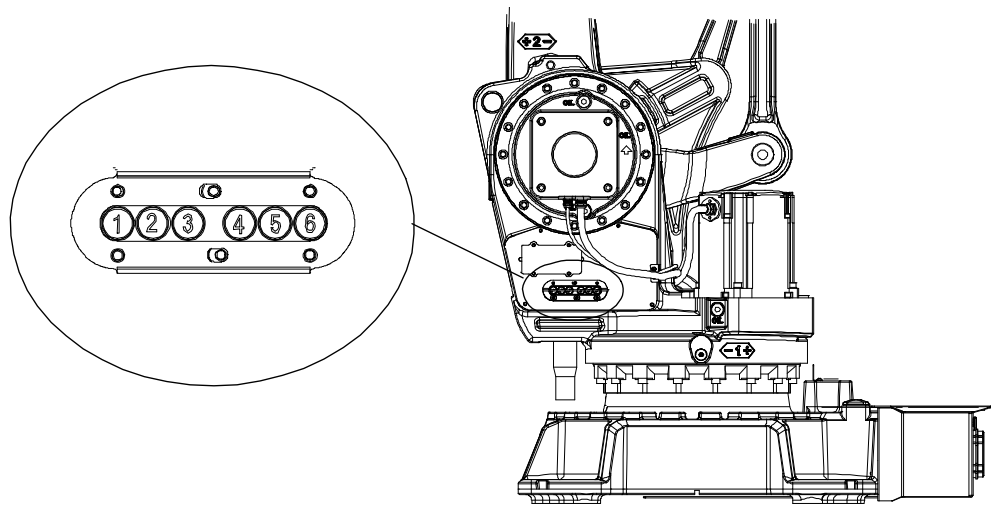

xx1000001157

Releasing the brakes

This procedure details how to release the holding brakes when the robot is equipped with an internal brake release unit.

	Action	Note
1	<p>The internal brake release unit is equipped with buttons for controlling the axes brakes. The buttons are numbered according to the numbers of the axes.</p> <p> Note</p> <p>Axes 4 and 5 do not exist!</p> <p>If the robot is not connected to the controller, power must be supplied to the connector R1.MP according to the section Supplying power to connector R1.MP on page 61.</p>	<p>Buttons are shown in figure Location of brake release unit on page 60.</p>

Continues on next page

	Action	Note
2	 DANGER When releasing the holding brakes, the robot axes may move very quickly and sometimes in unexpected ways. Make sure no personnel is near or beneath the robot.	
3	Release the holding brake on a particular robot axis by pressing the corresponding button on the internal brake release unit. The brake will function again as soon as the button is released.	

Supplying power to connector R1.MP

If the robot is not connected to the controller, power must be supplied to connector R1.MP on the robot, in order to enable the brake release buttons.

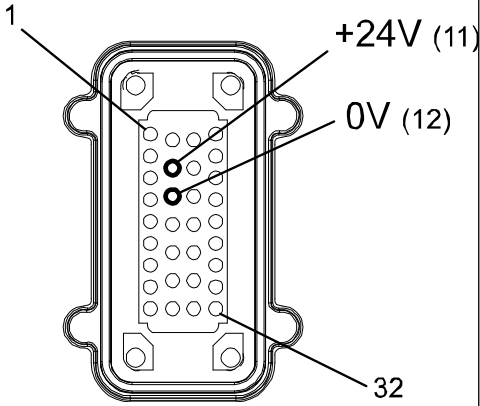
	Action	Note
1	 DANGER Incorrect connections, such as supplying power to the wrong pin, may cause all brakes to be released simultaneously!	
2	Supply 0V on pin 12 and 24V on pin 11.	 <p>xx0600002937</p>

2 Installation and commissioning

2.3.4 Lifting the base plate

2.3.4 Lifting the base plate

Required equipment

Equipment	Article number	Note
Lifting eye, M16	3HAC14457-4	3 pcs
Lifting slings		Length: approx. 2 m

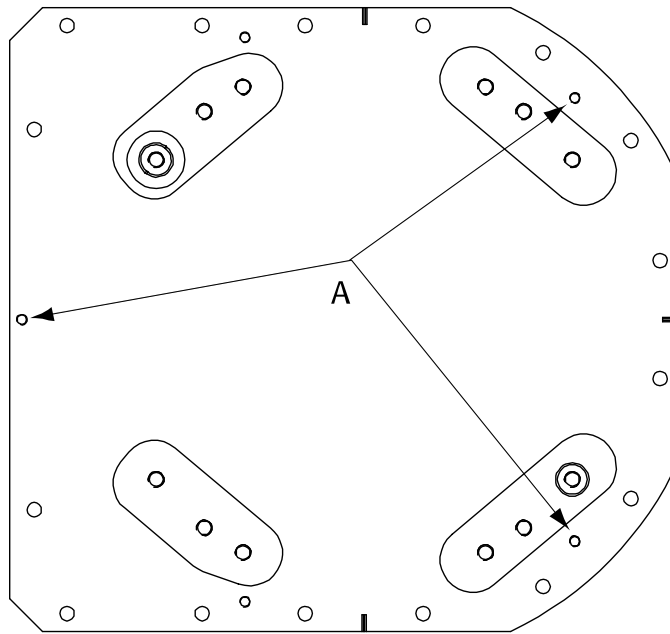

Hole configuration



xx0200000096

A	Attachment holes for lifting eyes (x3)
---	--

Lifting, base plate

	Action	Note
1	 CAUTION The base plate weighs 353 kg. All lifting accessories used must be sized accordingly.	
2	Fit lifting eyes in specified holes.	Shown in figure Hole configuration on page 62 .
3	Fit lifting slings to the eyes and to the lifting accessory.  CAUTION Lift and move the base plate very slowly. If the base plate starts to swing it is a risk for injuries or damage.	

2.3.5 Securing the base plate

Base plate, dimensions

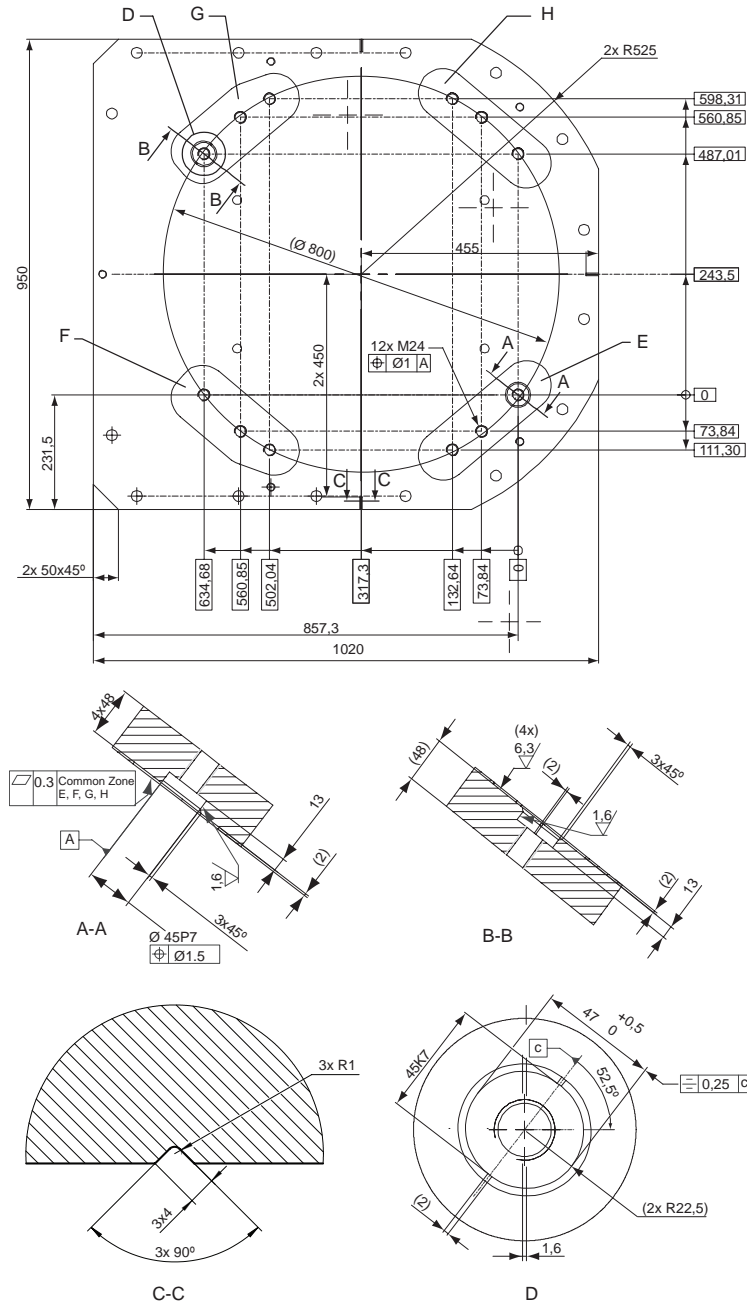

xx1000001053

E, F, G, H	Common tolerance zone (accuracy all over the base plate from one contact surface to the other)
------------	--

Continues on next page

2 Installation and commissioning

2.3.5 Securing the base plate

Continued

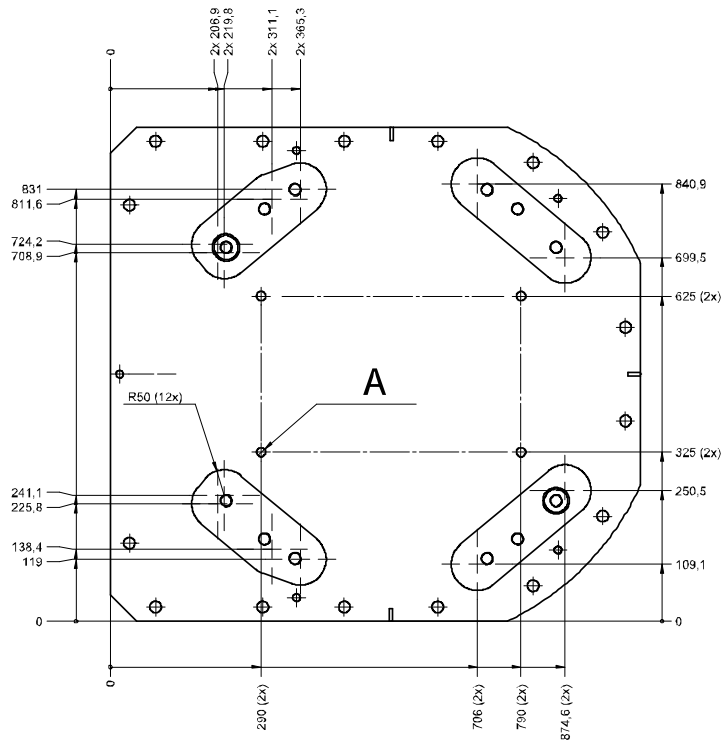
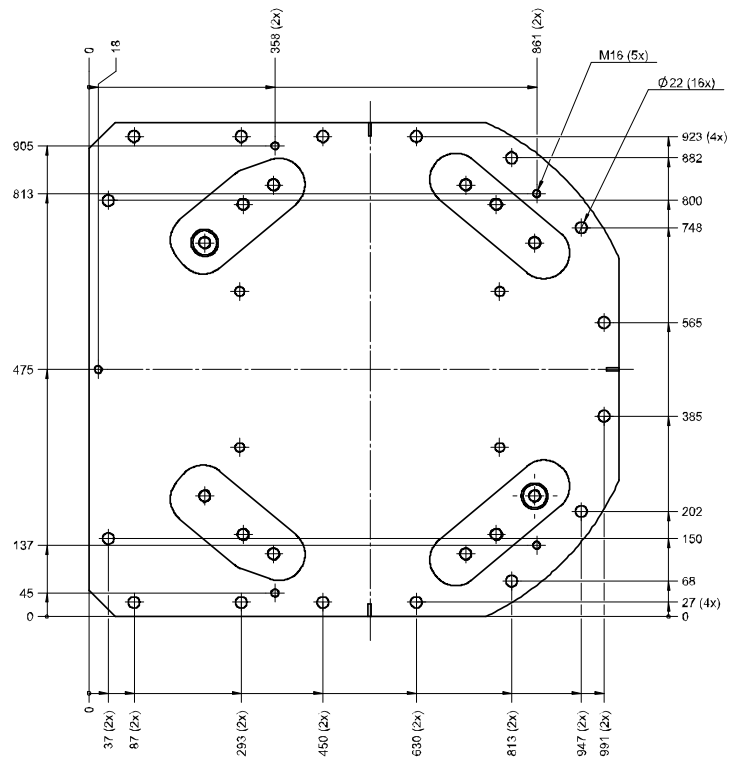

xx0400000715

A	Four holes for alternative clamping, 4x Ø18
----------	--

Continues on next page

Base plate, orienting grooves and leveling bolts

The illustration below shows the orienting grooves and attachment holes for leveling bolts in the base plate.

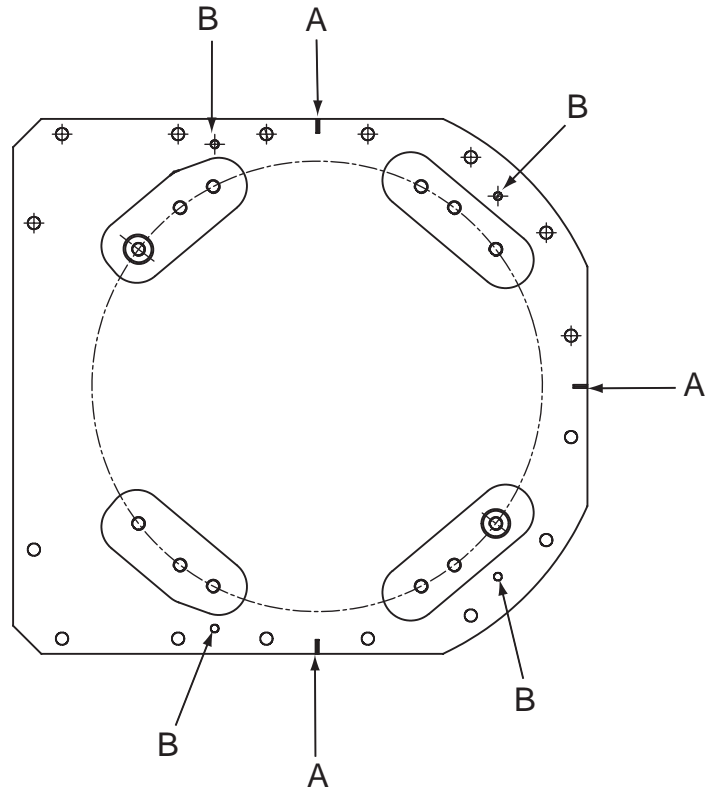

xx150000312

A	Orienting grooves (3 pcs)
B	Levelling bolts, attachment holes (4 pcs)

Continues on next page

2 Installation and commissioning

2.3.5 Securing the base plate

Continued

Base plate, guide sleeve holes

The illustration below shows the orienting grooves and guide sleeve holes in the base plate.

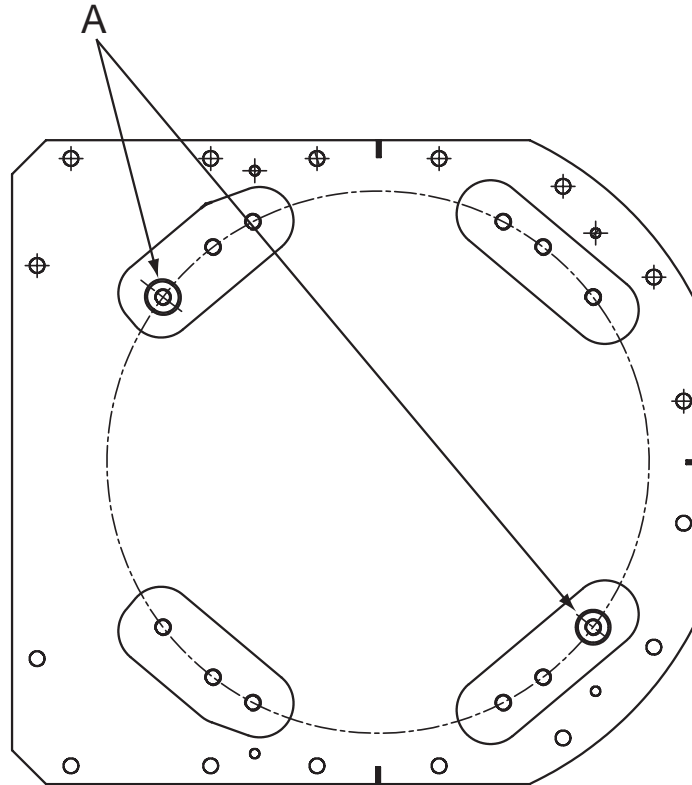

xx030000045

A	Guide sleeve holes (2 pcs)
---	----------------------------

Required equipment

Equipment	Article number	Note
Base plate		Includes <ul style="list-style-type: none"> guide sleeves, 3HAC12937-3 levelling screws, 9ADA120-79 attachment screws and washers for securing the robot to the base plate.
Standard toolkit	-	Content is defined in section Standard tools on page 398 .
Other tools and procedures may be required. See references to these procedures in the step-by-step instructions below.		These procedures include references to the tools required.

Base plate

This section details how to secure the base plate to the foundation.

	Action	Note
1	Make sure the foundation is levelled.	

Continues on next page

	Action	Note
2	 CAUTION The base plate weighs 353 kg! All lifting equipment used must be sized accordingly!	
3	Position base plate in relation to the robot work location using the grooves in the base plate.	Shown in figure Base plate, orienting grooves and leveling bolts on page 65 .
4	Lift the base plate to its mounting position.	Detailed in section Lifting the base plate on page 62 .
5	Use the base plate as a template and drill attachment holes as required by the selected bolt dimension.	Attachment holes: 16 pcs.
6	Fit the base plate and use the levelling bolts to level the base plate.	Shown in figure Base plate, orienting grooves and leveling bolts on page 65 .
7	If required, fit strips of sheet metal underneath the base plate to fill any gaps.	
8	Secure the base plate to the foundation with screws and sleeves.	
9	Recheck the four contact surfaces on the base plate to make sure the base plate is levelled and flat. If it is not, use pieces of sheet metal or similar to bring the base plate to a levelled position.	Maximum allowed deviation all over the base plate, from one contact surface to the other: 0.3 mm.

2 Installation and commissioning

2.3.6 Orienting and securing the robot

2.3.6 Orienting and securing the robot

General

This section details how to orient and secure the robot to the base plate in order to run the robot safely.

Illustration, robot fitted to base plate

This illustration shows the robot base fitted to the base plate.

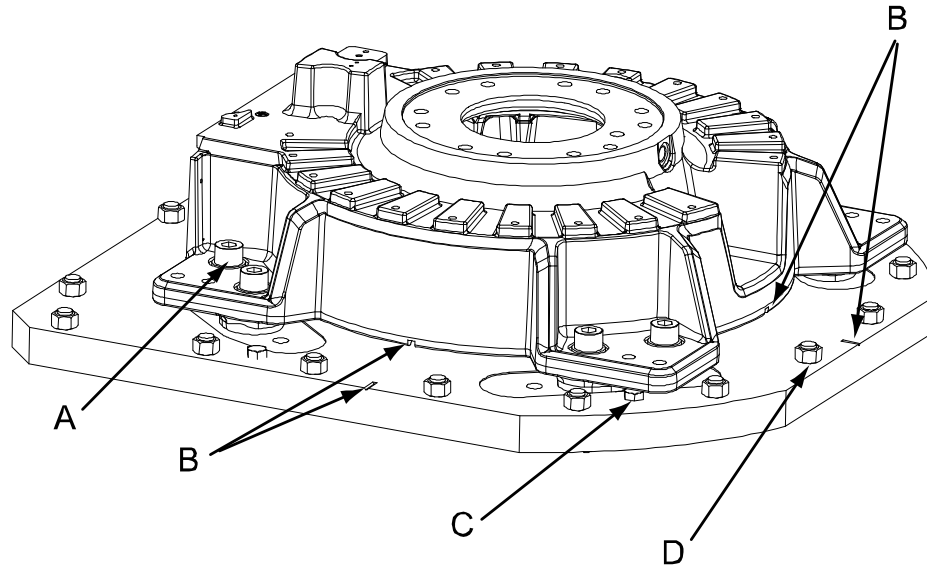

xx0600002933

A	Robot attachment bolts and washers, 8 pcs (M24 x 100)
B	Orienting grooves in the robot base and in the base plate
C	Levelling screws. Note! Remove before the robot base is fitted!
D	Base plate attachment screws

Attachment screws



The table below specifies the type of securing screws and washers to be used for securing the robot to the base plate/foundation.

Suitable screws, lightly lubricated:	M24 x 100
Quality:	Quality 8.8
Suitable washer:	Thickness: 4 mm Outer diameter: 44 mm Inner diameter: 25 mm
Tightening torque:	725 Nm

Continues on next page

Securing the robot

Use this procedure to secure robot to base plate after fitting plate to the foundation.

	Action	Note
1	Lift the robot.	See section Lifting robot with round-slings on page 58 .
2	Move robot to the vicinity of its installation location.	
3	Fit two guide sleeves to the <i>guide sleeve holes</i> in the base plate.	Shown in figure Base plate, guide sleeve holes on page 66 .  Note One of the guide sleeve holes is elongated!
4	Guide the robot gently using two M24 screws while lowering it into its mounting position.	Make sure the robot base is correctly fitted onto the guide sleeves!
5	Fit the <i>bolts and washers</i> in the base attachment holes.	Specified in Attachment screws on page 68 . Shown in figure Illustration, robot fitted to base plate on page 68 .  Note Lightly lubricate screws before assembly!
6	Tighten bolts in a criss-cross pattern to ensure that the base is not distorted.	

Continues on next page

2 Installation and commissioning

2.3.6 Orienting and securing the robot

Continued

Hole configuration, base

This illustration shows the hole configuration used when securing the robot.

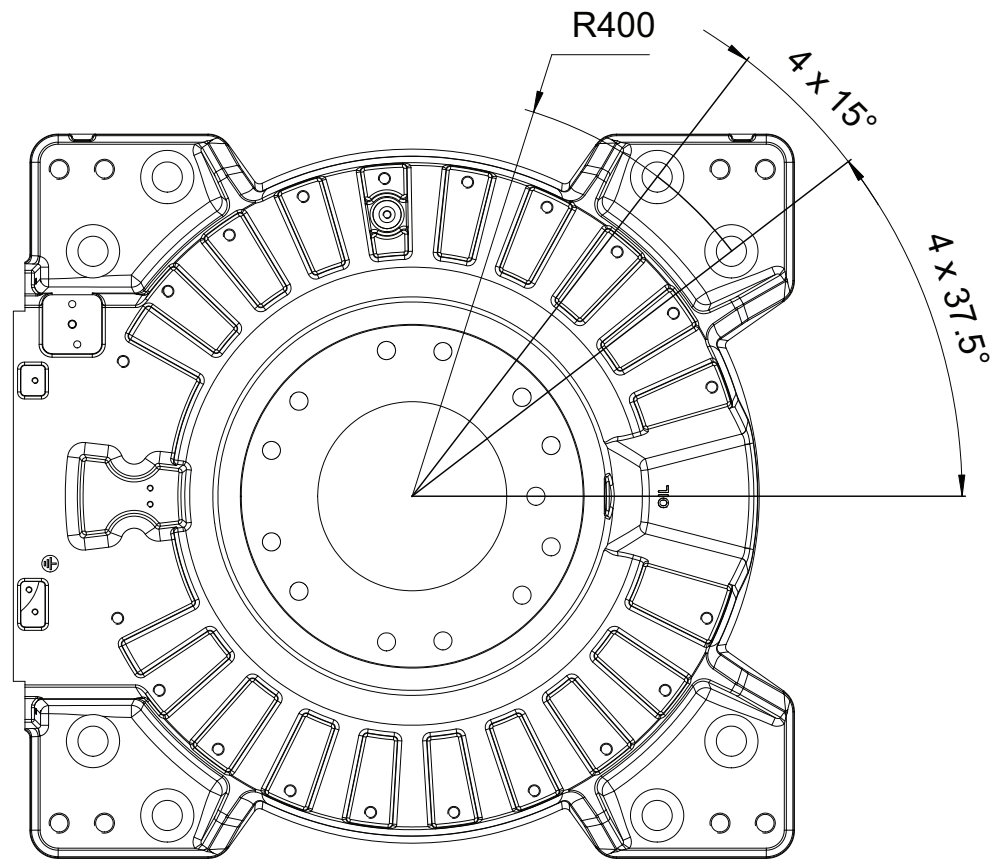

xx0600002932

Continues on next page

Cross section, guide sleeve hole

This illustration shows the cross section of the guide sleeve holes.

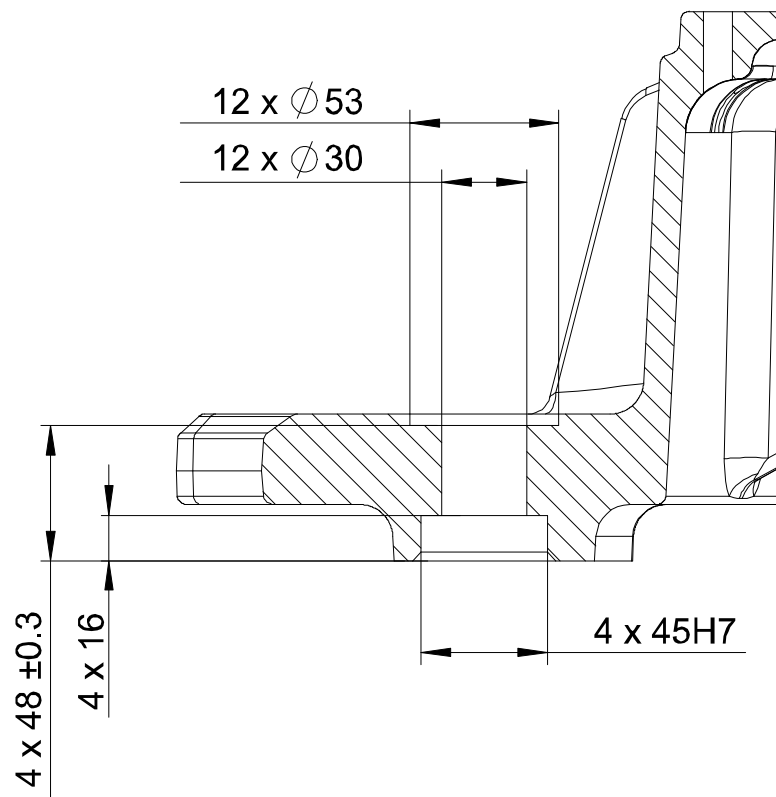

xx0600002934

2 Installation and commissioning

2.3.7 Fitting equipment on robot

2.3.7 Fitting equipment on robot

General

The robot features mounting holes for additional equipment.



Note

All equipment and cables used on the robot, must be designed and fitted not to damage the robot and/or its parts.

Illustration, fitting of extra equipment on upper arm

The illustration below shows the mounting holes available for fitting extra equipment on the upper arm.

For mounting of an external vacuum hose there are six holes on the upper arm. The maximum weight for the vacuum hose and fastening device is 35 kg.

Continues on next page

2 Installation and commissioning

2.3.7 Fitting equipment on robot

Continued

Note! The weight of the extra equipment on the upper arm must be deducted from the maximal handling capacity.

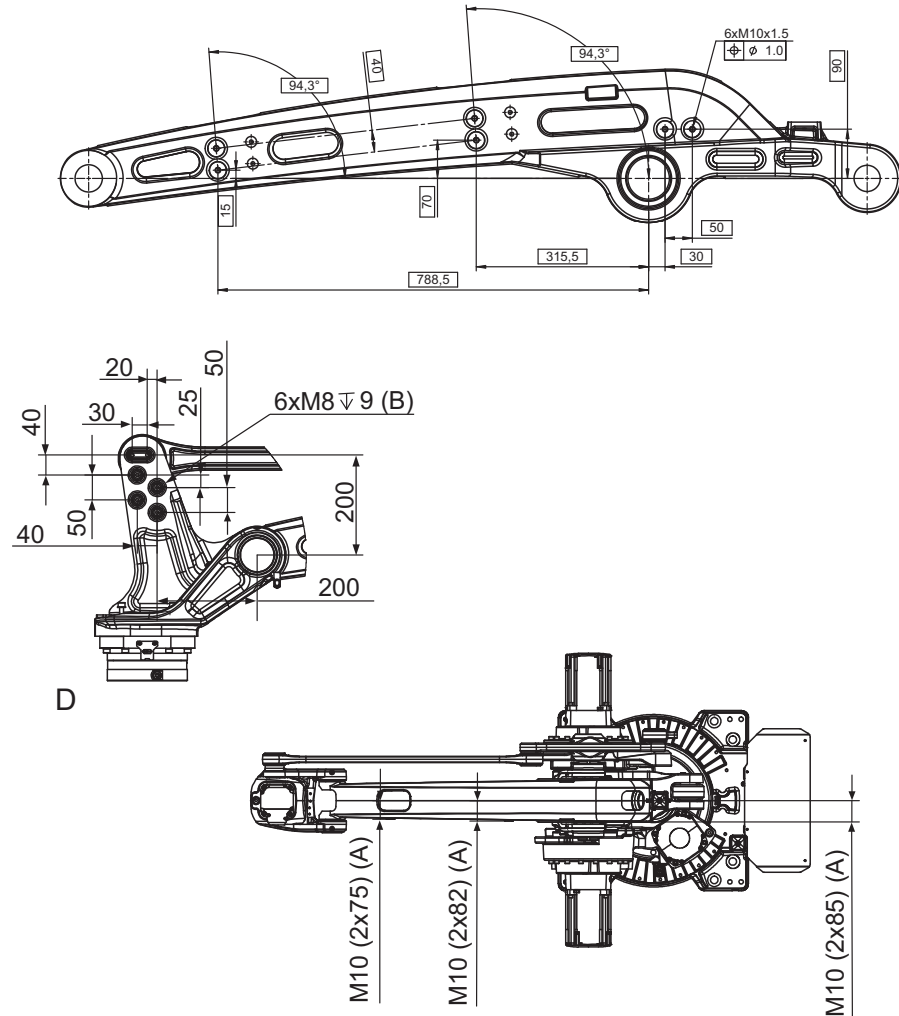

xx1000001041

A	M10 mounting holes on upper arm
B	Drill depth 15 mm

Continues on next page

2 Installation and commissioning

2.3.7 Fitting equipment on robot

Continued

Illustration, fitting on turning disk

The illustration below shows the mounting holes available for fitting equipment on the turning disk.

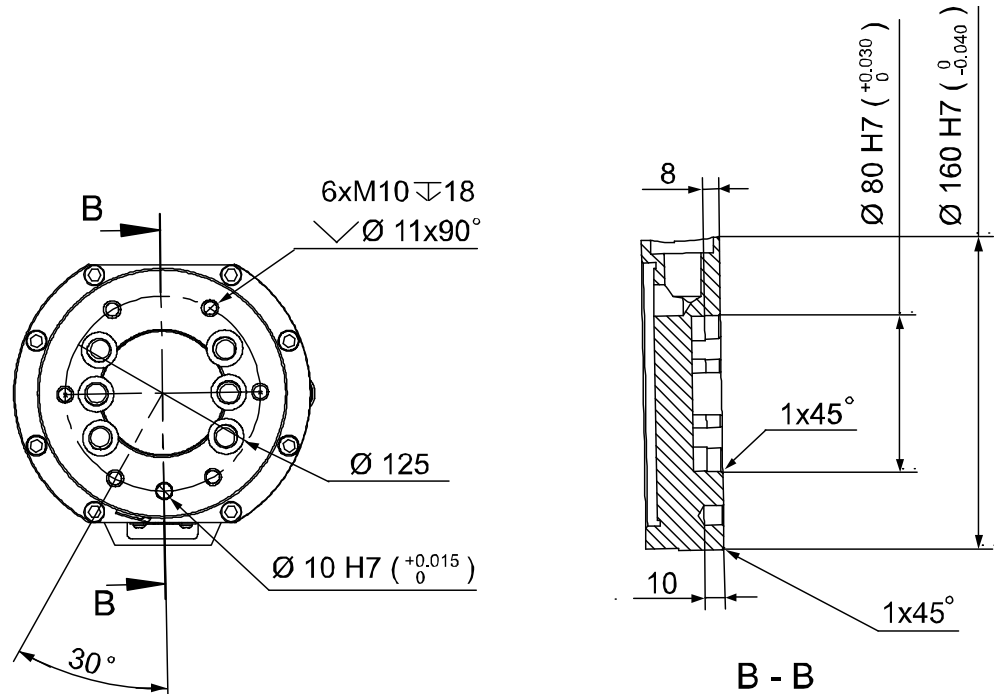

xx1000001042

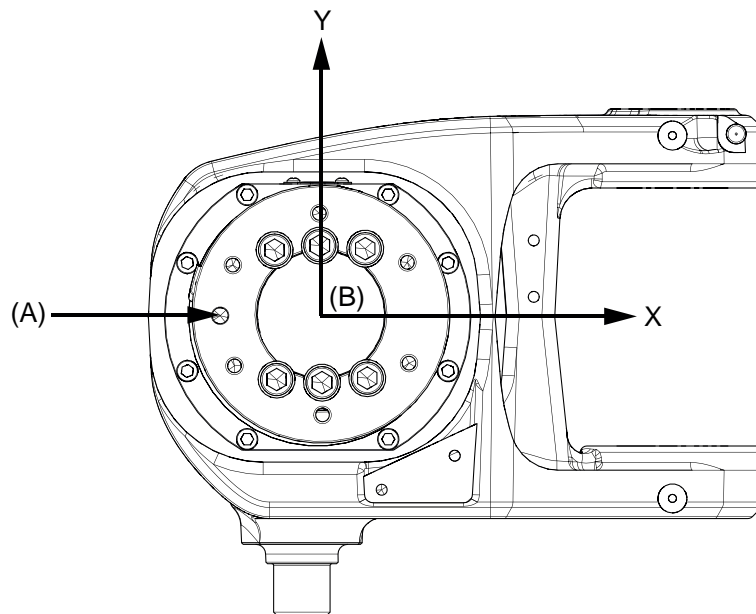

xx1800001402

-	Tool flange in bottom view
A	Locating hole
B	Tool coordinate system

Continues on next page

Fastener quality

When fitting tools on the tool flange, only use screws with quality 12.9. For other equipment use suitable screws and tightening torque for your application.

2 Installation and commissioning

2.3.8 Loads fitted to the robot, stopping time and braking distances

2.3.8 Loads fitted to the robot, stopping time and braking distances

General

Any loads mounted on the robot must be defined correctly and carefully (with regard to the position of center of gravity and mass moments of inertia) in order to avoid jolting movements and overloading motors, gears and structure.



CAUTION

Incorrectly defined loads may result in operational stops or major damage to the robot.

References

Load diagrams, permitted extra loads (equipment) and their positions are specified in the product specification. The loads must be defined in the software.

- *Operating manual - IRC5 with FlexPendant*
- *Operating manual - OmniCore*

Stopping time and braking distances

The performance of the motor brake depends on if there are any loads attached to the robot. For more information, see product specification listed in [References on page 10](#).

2.4 Installation of options

2.4.1 Installation of cooling fan for axis-1 motor (Option 87-1)

General



Note

The cooling fan is available only for robots with IRC5 controllers.

A cooling fan (option 87-1) can be installed on the axis-1 motor.

Location of cooling fan

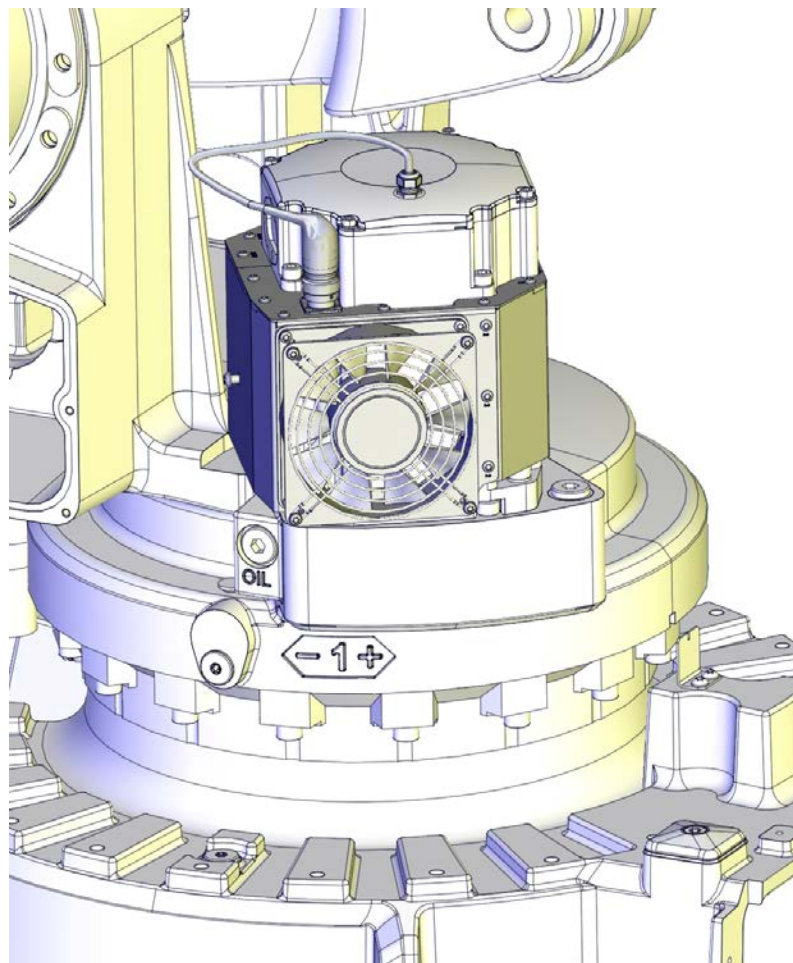

xx1300000168

Continues on next page

2 Installation and commissioning

2.4.1 Installation of cooling fan for axis-1 motor (Option 87-1)

Continued

Illustration of cooling fan

The details of the cooling fan are shown in the figure below.

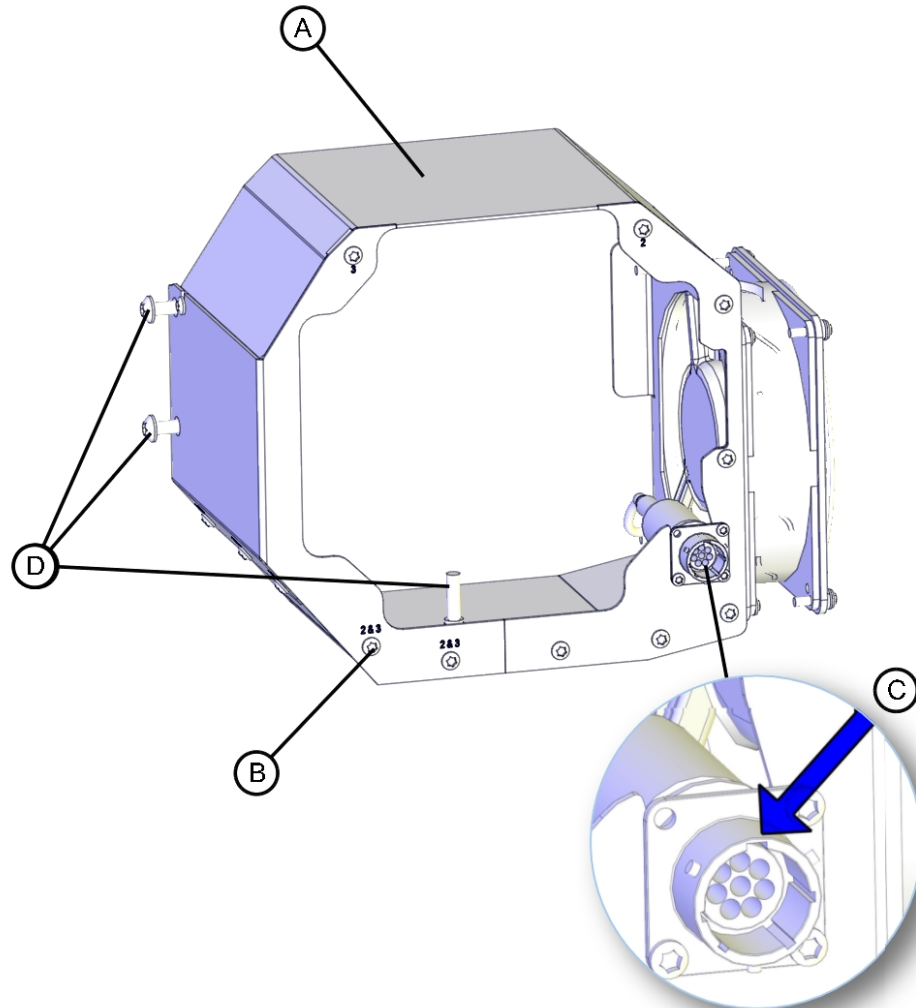

xx1300000763

A	Fan box
B	Attachment screws (16 pcs)
C	Groove in the connector
D	Tightening screws (3 pcs)

Required equipment

Equipment	Art. no.	Note
Cooling fan	See <i>Product manual, spare parts - IRB 460</i> .	
Fan axis-1 cable harness		Choose this if equipping the robot with a cooling fan on the axis-1 motor.
Motor cover		Choose this if equipping the robot with a cooling fan on the axis-1 motor.

Continues on next page

2 Installation and commissioning

2.4.1 Installation of cooling fan for axis-1 motor (Option 87-1)

Continued

Equipment	Art. no.	Note
Locking liquid	-	Loctite 243. Used for the three tightening screws.
Standard toolkit	-	Content is defined in section Standard tools on page 398 .
Circuit diagram	-	See chapter Circuit diagrams on page 405 .
Other tools and procedures may be required. See references to these procedures in the step-by-step instructions below.		These procedures include references to the tools required.

Installing the cooling fan

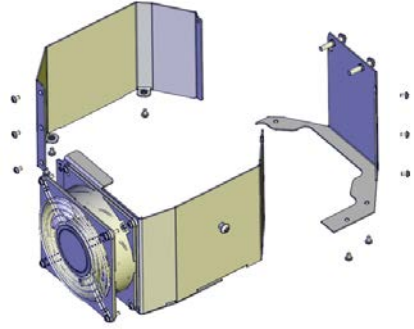
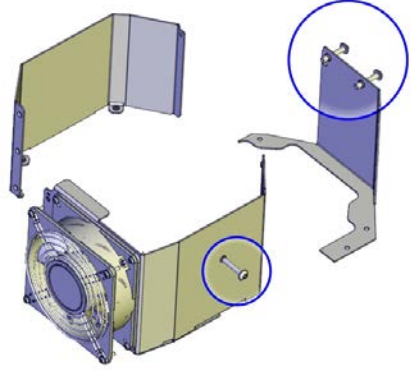
	Action	Note
1	 <p>DANGER</p> <p>Turn off all:</p> <ul style="list-style-type: none"> • electric power supply to the robot • hydraulic pressure supply to the robot • air pressure supply to the robot <p>Before entering the robot working area.</p>	
2	Disassemble the parts of the fan box by removing the attachment screws.	 <p>xx1300000843</p>
3	Loosen the three tightening screws, to avoid damaging the surfaces of the motor when fitting the fan box.	 <p>xx1300000844</p>

Continues on next page

2 Installation and commissioning

2.4.1 Installation of cooling fan for axis-1 motor (Option 87-1)

Continued

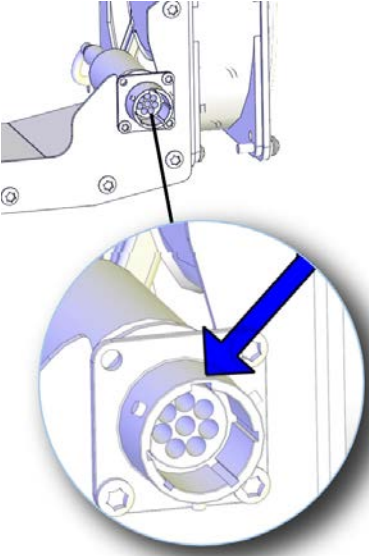
	Action	Note
4	Insert and turn the connector so that the groove points inwards, as shown in the figure.	 <p data-bbox="986 907 1093 929">xx130000764</p>
5	Temporarily lift the motor cabling out of the way to make room for the fan box.	
6	Fit the parts of the fan box to the motor and reassemble with the attachment screws.	
7	Lift the fan box so that it does not rest directly on the robot and secure the box with the three tightening screws, using locking liquid. Tighten them properly so that the box is firmly attached to the motor.	
8	Install the cabling and make adjustments in RobotWare, as described in the following procedures.	

Continues on next page

Illustration of separate cable for the fan

The figure below shows the cabling used for the fan on axis 1.

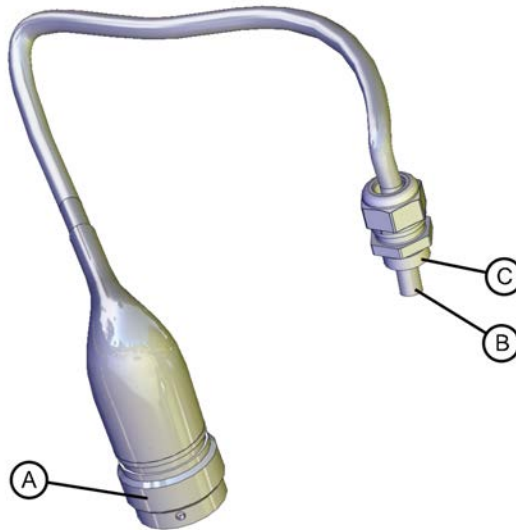

xx1300000765

A	Connector R3.FAN. Connected to the fan box.
B	Connector R2.FAN. Connected to the robot cable harness.
C	Screw M12x1.5. Secures the cable to the motor cover.

Installing the separate cable for the fan

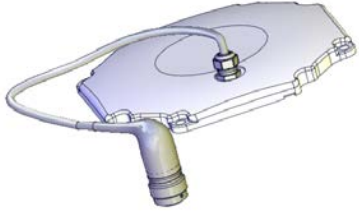
	Action	Note
1	Move the robot to its calibration position.	
2	 DANGER Turn off all: <ul style="list-style-type: none"> • electric power supply to the robot • hydraulic pressure supply to the robot • air pressure supply to the robot Before entering the robot working area.	
3	Insert the fan cable through the motor cover and tighten the screw.	 <p>xx1300000766</p>

Continues on next page

2 Installation and commissioning

2.4.1 Installation of cooling fan for axis-1 motor (Option 87-1)

Continued

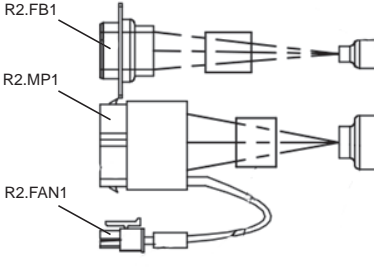
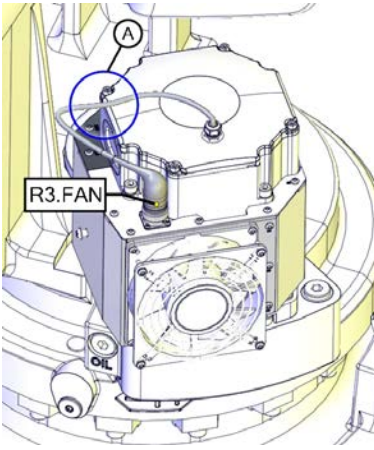
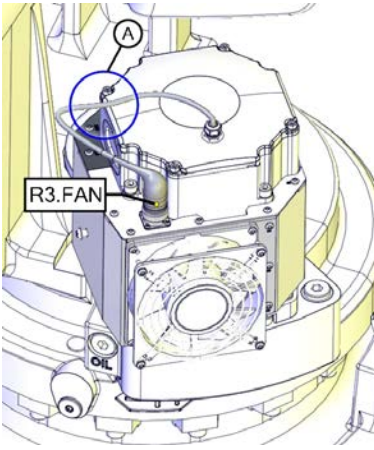
	Action	Note
4	Connect the connector R2.FAN to the connector R2.FAN1 on the robot cable harness.	 <p>R2.FB1</p> <p>R2.MP1</p> <p>R2.FAN1</p> <p>xx1300000767</p>
5	Fit the motor cover to the motor.  Note Make sure to fit the motor cover at the correct direction, see the figure.	 <p>R3.FAN</p> <p>A</p> <p>xx1300000768</p>
6	Connect the connector R3.FAN to the connector on the fan box.	
7	Strap the cable onto the axis-1 motor cables (at position A).	

2.4.2 Installation of signal lamp, upper arm (option), on IRC5 robots

General

As an option, a signal lamp can be installed on the robot. The lamp is activated when the controller is in the MOTORS ON state.

Location of signal lamp, upper arm

The signal lamp is located on the tilthouse unit, as shown in figure.

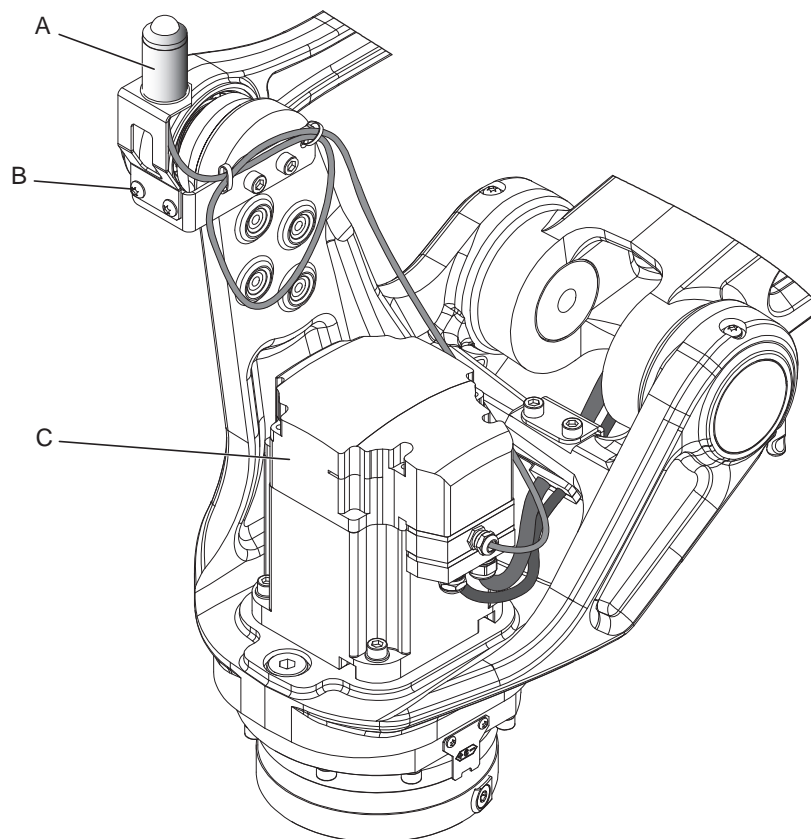

xx1000001287

A	Signal lamp
B	Attachment screw M6x8 (2 pcs)
C	Motor cover

Required equipment

Equipment, etc.	Article number	Note
Signal lamp kit	Spare parts on page 403.	Complete kit with signal lamp, cables, adapter, gasket, screws etc.
Gasket	3HAC033206-001	Fitted between motor and cable gland, replace if damaged.
Standard toolkit		Content is defined in section Standard tools on page 398.

Continues on next page

2 Installation and commissioning

2.4.2 Installation of signal lamp, upper arm (option), on IRC5 robots

Continued

Equipment, etc.	Article number	Note
Other tools and procedures may be required. See references to these procedures in the step-by-step instructions below.		

Signal lamp kit

Figure shows signal lamp kit on the robot.

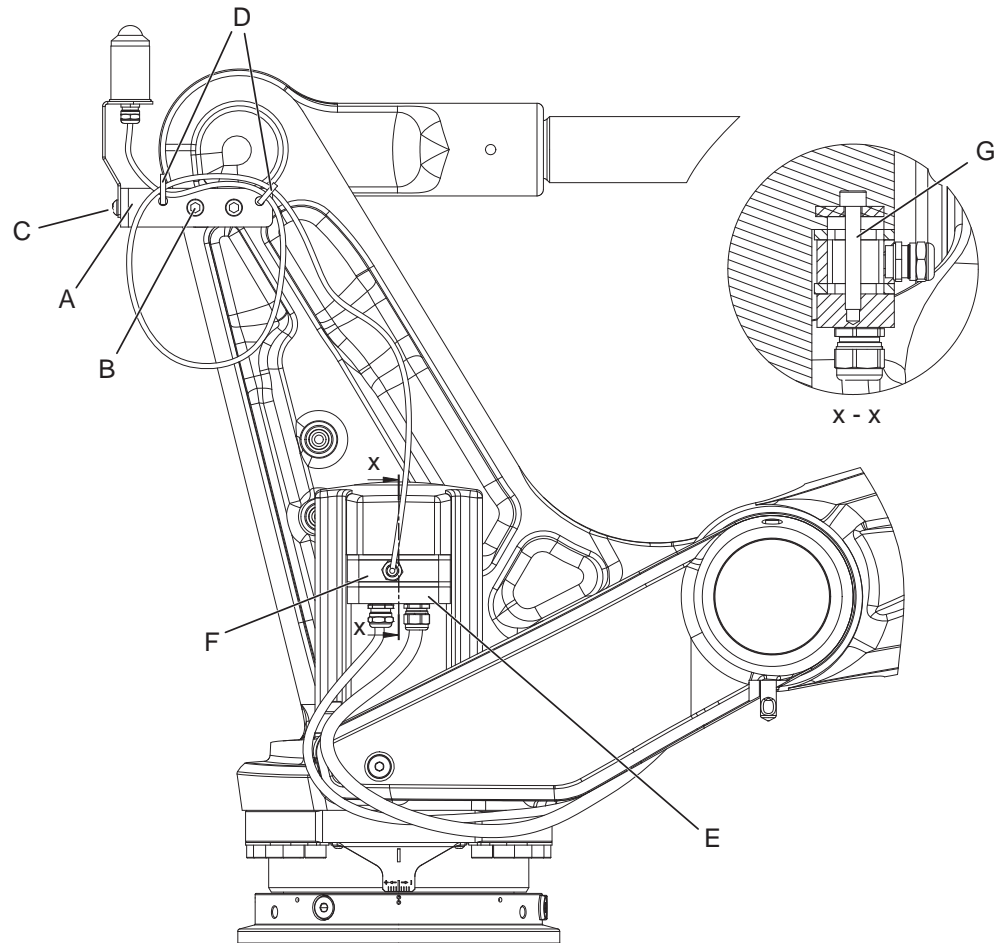

xx1000001064

A	Signal lamp bracket
B	Attachment screws for the bracket, M8x12 (2 pcs)
C	Attachment screws for the signal lamp (2 pcs)
D	Cable straps (2 pcs)
E	Cable gland cover
F	Motor adapter including gasket
G	Attachment screw, M6x40 (1 pc)

Continues on next page

Installation, signal lamp

Use this procedure to install the signal lamp to the robot.

	Action	Note
1	Fit the <i>signal lamp bracket</i> to the tilthouse, with two <i>attachment screws</i> .	See figure Signal lamp kit on page 84 .
2	Fit the signal lamp to the bracket, with two <i>attachment screws</i> . (not applicable for IRB 760 - 445/3.2)	See figure Signal lamp kit on page 84 .
3	<p>If not already connected, connect the signal lamp to the axis 6 motor.</p> <p> DANGER</p> <p>Turn off all:</p> <ul style="list-style-type: none"> • electric power supply • hydraulic pressure supply • air pressure supply <p>to the robot, before entering the robot working area.</p>	See Electrical installation, signal lamp on page 85 .
4	Arrange the signal cable in a loop at the signal cable bracket with two <i>cable straps</i> .	See figure Signal lamp kit on page 84 .

Electrical installation, signal lamp

Use this procedure to connect the signal lamp to the axis 6 motor. The instruction requires that the signal lamp is already mounted to the tilthouse.

	Action	Note
1	<p> DANGER</p> <p>Turn off all:</p> <ul style="list-style-type: none"> • electric power supply • hydraulic pressure supply • air pressure supply <p>to the robot, before entering the robot working area.</p>	
2	Remove the <i>motor cover</i> by unscrewing the four attachment screws.	See figure Location of signal lamp, upper arm on page 83 .
3	Disconnect the motor connectors.	

Continues on next page

2 Installation and commissioning

2.4.2 Installation of signal lamp, upper arm (option), on IRC5 robots

Continued

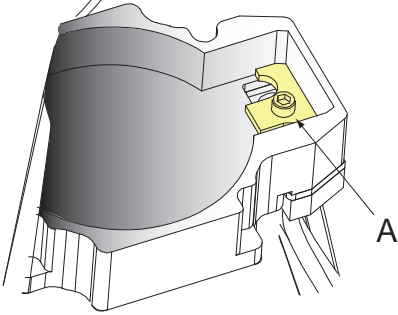
	Action	Note
4	<p>Remove the <i>cable gland cover</i> at the cable exit by removing the attachment screw.</p> <p>Replace the screw with a longer one, when refitting in following steps (enclosed in the signal lamp kit).</p>	<p>See figure Signal lamp kit on page 84.</p>  <p>xx0600002694</p> <p>A Screw that holds the cable gland</p>
5	<p>See how the <i>adapter</i> is going to be fitted to the motor and then fit the <i>gasket</i> to the side of the adapter that will be facing downwards. The gasket will protect the mating surfaces of the adapter and the cable gland cover.</p>	<p>Enclosed with signal lamp kit.</p>
6	<p>Place <i>gasket and motor adapter</i> above the cable gland cover and refit the complete package to the motor. Secure with <i>attachment screw M6x40</i>, enclosed with the signal lamp kit.</p>	<p>See figure Signal lamp kit on page 84.</p> <p>In addition to the enclosed gasket that is fitted to the adapter, there is also a gasket located on the motor. Make sure it does not get damaged. Replace if damaged!</p>
7	<p>Push the signal cable through the hole in the adapter and connect it to the connector inside the motor.</p>	
8	<p>Loosen the motor cables at the glands and adjust their lengths with + 20 mm into the motor.</p>	
9	<p>Connect motor cables inside the motor.</p>	
10	<p>Secure motor cables at cable gland again.</p>	
11	<p>Fit the motor cover with the attachment screws. Make sure the cabling is placed correctly when refitting the cover and does not get jammed.</p>	

2.4.3 Installation of signal lamp for OmniCore robots

Description

A signal lamp with a yellow fixed light can be mounted in the cell or any other visible location, and driven by I/O signal or MON_LAMP signal from the controller.

Function

The lamp is active in MOTORS ON mode.

Installation of signal lamp from I/O signal

	Action
1	 DANGER Make sure that all supplies for electrical power, hydraulic pressure, and air pressure are turned off.
2	Configure the lamp by adding a <i>System Output</i> type signal with status set to <i>Motors On State</i> .
3	The lamp is now ready for use and is lit in MOTORS ON mode.

Installation of signal lamp from MON_LAMP signal

	Action
1	 DANGER Make sure that all supplies for electrical power, hydraulic pressure, and air pressure are turned off.
2	The lamp is now ready for use and is lit in MOTORS ON mode.

Further information

Further information about the MOTORS ON/MOTORS OFF mode may be found in the product manual for the controller.

Further information about how to set up I/O system may be found in *Technical reference manual - System parameters*.

2 Installation and commissioning

2.5.1 Introduction

2.5 Restricting the working range

2.5.1 Introduction

General

When installing the robot, make sure that it can move freely within its entire working space. If there is a risk that it may collide with other objects, its working space should be limited.

The working range of the following axis may be restricted:

- Axis 1, hardware (mechanical stop) and software (EPS) .

As standard configuration, axis 1 is allowed to move $\pm 165^\circ$.

This section describes how to install hardware that restricts the working range.

Note! Adjustments must also be made in the robot configuration software (system parameters). References to relevant manuals are included in the installation procedures.

2.5.2 Mechanically restricting the working range of axis 1

General

The working range of axis 1 is limited by fixed mechanical stops and adjustment of the system parameter configuration. The working range can be reduced by adding additional mechanical stops giving 7.5 or 15 graduation, between 22.5° and 135° in both directions.

Mechanical stops, axis 1

The illustration shows the mounting position of the stop pin and one of the additional mechanical stops available for axis 1.

The figure shows IRB 6640 but is also valid for IRB 460.

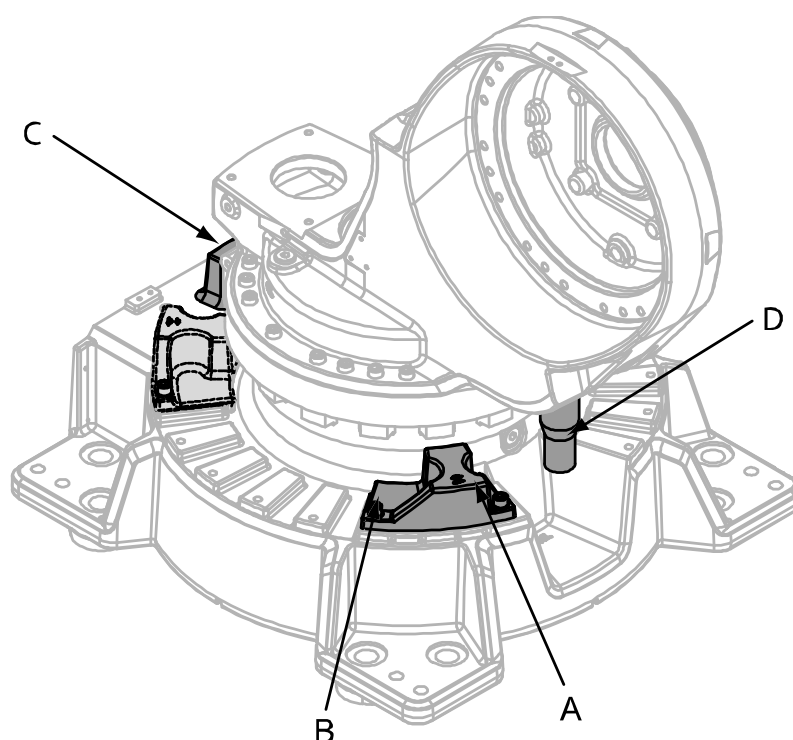

xx0600002938

A	Movable mechanical stop
B	Attachment screw plus washer, M12 x 40 quality 12.9 (2 pcs)
C	Fixed mechanical stop
D	Mechanical stop pin axis 1

Continues on next page

2 Installation and commissioning

2.5.2 Mechanically restricting the working range of axis 1



Continued

Required equipment

Equipment, etc.	Article number	Note
Movable mechanical stop set, axis 1 (+15°/-7.5°)	3HAC025204-003	Includes: <ul style="list-style-type: none"> • one stop (+15° / -7.5°), 3HAC025366-001 • one stop (+7.5° / -15°), 3HAC025367-001 • attachment screws and washers • document for movable mech.stop, 3HAC025204-002
Standard toolkit	-	
<i>Technical reference manual - System parameters</i>	-	Article number is specified in section References on page 10 .

Installation, mechanical stops axis 1

Use this procedure to fit the additional mechanical stops to axis 1 of the robot. An assembly drawing is also enclosed with the product.

	Action	Note
1	 DANGER Turn off all: <ul style="list-style-type: none"> • electric power supply to the robot • hydraulic pressure supply to the robot • air pressure supply to the robot Before entering the robot working area.	
2	Fit the additional mechanical stop to the frame according to the figure Mechanical stops, axis 1 on page 89 .	Tightening torque: 120 Nm.
3	Adjust the software working range limitations (system parameter configuration) to correspond to the mechanical limitations.	The system parameters that must be changed (<i>Upper joint bound</i> and <i>Lower joint bound</i>) are described in <i>Technical reference manual - System parameters</i> .
4	 WARNING If the mechanical stop pin is deformed after a hard collision, it must be replaced! Deformed <i>movable stops</i> and/or <i>additional stops</i> as well as deformed <i>attachment screws</i> must also be replaced after a hard collision.	

2.6 Robot in cold environments

2.6.1 Start of robot in cold environments

Introduction

This section describes how to start the robot in a cold environment if it is not starting the normal way.

Problems with starting the robot

Event message from Motion Supervision

Use this procedure if an event message indicates a problem with Motion supervision at start-up. More information about Motion Supervision is found in *Technical reference manual - System parameters*.

	Action	Note
1	Turn off Motion Supervision.	
2	Start the robot.	
3	When the robot has reached normal working temperature, the Motion Supervision can be turned on again.	

Robot stopping with other event message

Use this procedure if the robot is not starting.

	Action	Note
1	Start the robot with its normal program but with reduced speed.	The speed can be regulated with the RAPID instruction <code>VelSet</code> .

Adjusting the speed and acceleration during warm-up

Depending on how cold the environment is and what program is being used, the speed might need to be ramped up until reached maximum. The table shows examples of how to adjust the speed:

Work cycles	AccSet	Speed/velocity
3 Work cycles	20, 20	v100 (100 mm/s)
5 Work cycles	40, 40	v400 (400 mm/s)
5 Work cycles	60, 60	v600 (600 mm/s)
5 Work cycles	100, 100	v1000 (1000 mm/s)
More than 5 Work cycles	100, 100	Max.

If the program consists of large wrist movements, it is possible that the reorientation velocity, which is always high in predefined velocities, needs to be included in the ramping up.

2 Installation and commissioning

2.7.1 Robot cabling and connection points

2.7 Electrical connections

2.7.1 Robot cabling and connection points

Introduction

Connect the robot and controller to each other after securing them to the foundation. The lists below specify which cables to use for each respective application.



CAUTION

Connect the male and female connectors perfectly aligned horizontally to avoid any kind of tilt or skew.



CAUTION

Verify that the serial number is according to the number(s) in the *Declaration of Incorporation (DoI)*.

Main cable categories

All cables between the robot and controller are divided into the following categories:

Cable category	Description
Robot cables	Handles power supply to and control of the robot's motors as well as feedback from the serial measurement board. Specified in the table Robot cables on page 92 .
Customer cables (option)	Handles communication with equipment fitted on the robot by the customer, low voltage signals and high voltage power supply + protective ground. See the product manual for the controller, see document number in References on page 10 .

Robot cables

These cables are included in the standard delivery. They are completely pre-manufactured and ready to plug in.

Cable sub-category	Description	Connection point, cabinet	Connection point, robot
Robot cable, power	Transfers drive power from the drive units in the control cabinet to the robot motors.	XS1 (IRC5 controllers) X1 (OmniCore controllers)	R1.MP
Robot cable, signals	Transfers resolver data from and power supply to the serial measurement board.	XS2 (IRC5 controllers) X2 (OmniCore controllers)	R1.SMB

Robot cable, power

Cable	Art. no.
Robot cable, power: 7 m	3HAC026787-001

Continues on next page

2 Installation and commissioning

2.7.1 Robot cabling and connection points

Continued

Cable	Art. no.
Robot cable, power: 15 m	3HAC026787-002
Robot cable, power: 22 m	3HAC026787-003
Robot cable, power: 30 m	3HAC026787-004

Robot cable, signals

Cable	Art. no.
Robot cable signal, shielded: 7 m	3HAC068917-001
Robot cable signal, shielded: 15 m	3HAC068918-001
Robot cable signal, shielded: 22 m	3HAC068919-001
Robot cable signal, shielded: 30 m	3HAC068920-001

Bending radius for static floor cables

The minimum bending radius is 10 times the cable diameter for static floor cables.

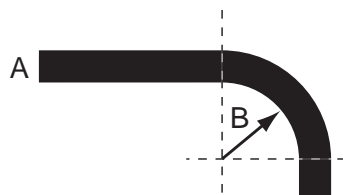

xx1600002016

A	Diameter
B	Diameter x10

Continues on next page

2 Installation and commissioning

2.7.1 Robot cabling and connection points

Continued

Grounding and bonding point on manipulator

There is a grounding/bonding point on the manipulator base. The grounding/bonding point is used for potential equalizing between control cabinet, manipulator and any peripheral devices.

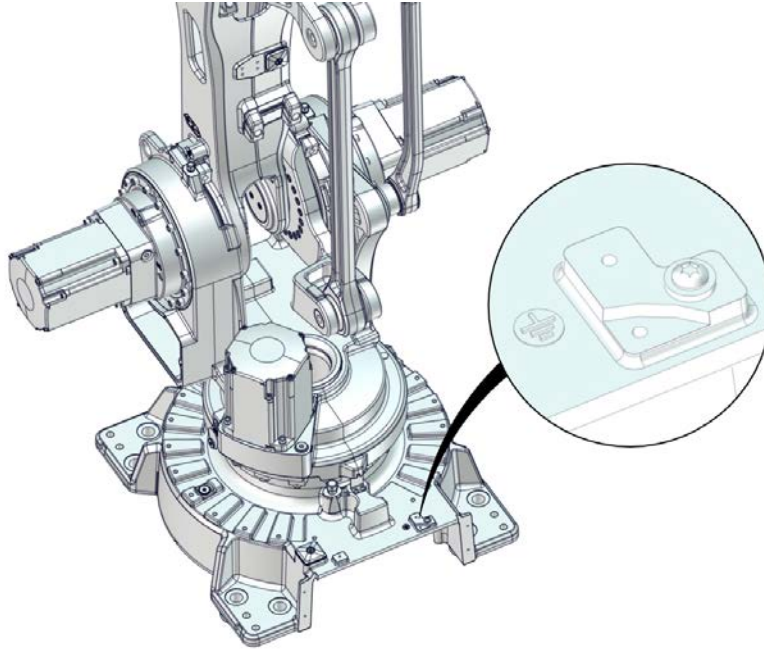

xx1600001956

2.7.2 Customer connectors on the manipulator

Introduction

The customer cables are routed internally with the manipulator cable harness. For more information and specifications for the connections. See section *Customer connections* in the Product Specification.

Location of customer connectors on manipulator

Customer connectors, base

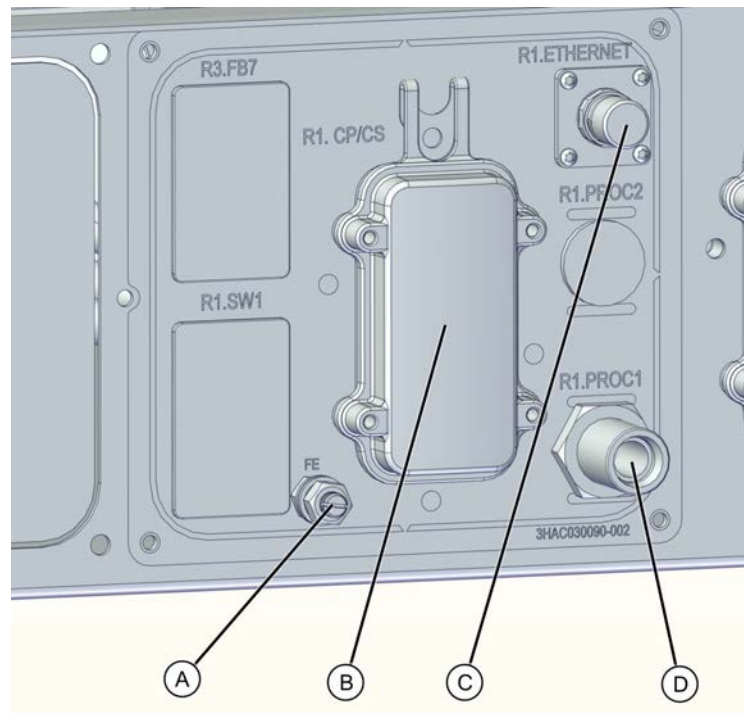

xx2100001979

Pos	Name	Description
A	FE	Grounding point
B	R1.CP/CS	Customer power/signal
C	R1.ETHERNET	Bus communication Ethernet IP
D	R1.PROC1	Process connector on the manipulator base.

Continues on next page

2 Installation and commissioning

2.7.2 Customer connectors on the manipulator

Continued

Customer connectors, wrist

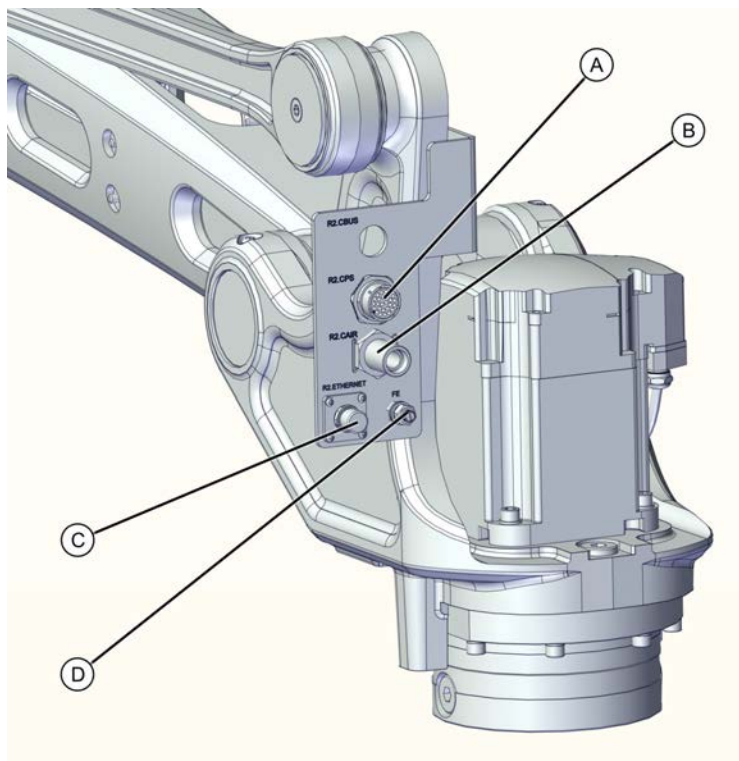

xx2100001980

Pos	Name	Description
A	R1.CPS	Customer power/signal connector
B	R2.CAIR	Customer air
C	R1.ETHERNET	Bus communication Ethernet IP
D	FE	Grounding point

2.8 Test run after installation, maintenance, or repair

Safe handling

Use the following procedure after installation, maintenance, or repair, before initiating motion.



DANGER

Initiating motion without fulfilling the following aspects, may increase the risk for injury or cause damage to the robot.

	Action
1	Remove all tools and foreign objects from the robot and its working area.
2	Verify that the robot is properly secured to its position by all screws, before it is powered up.
3	Verify that any safety equipment installed to secure the position or restrict the robot motion during service activity is removed.
4	Verify that the fixture and work piece are well secured, if applicable.
5	Verify that all safety equipment is installed, as designed for the application.
6	Verify that no personnel are inside the safeguarded space.
7	If maintenance or repair has been done, verify the function of the part that was maintained.
8	Verify the application in the operating mode manual reduced speed.

Collision risks



CAUTION

When programming the movements of the robot, always identify potential collision risks before initiating motion.

This page is intentionally left blank

3 Maintenance

3.1 Introduction

Structure of this chapter

This chapter describes all the maintenance activities recommended for the IRB 460.

It is based on the maintenance schedule found at the beginning of the chapter. The schedule contains information about required maintenance activities including intervals, and refers to procedures for the activities.

Each procedure contains all the information required to perform the activity, including required tools and materials.

The procedures are gathered in different sections and divided according to the maintenance activity.

Safety information

Observe all safety information before conducting any service work.

There are general safety aspects that must be read through, as well as more specific safety information that describes the danger and safety risks when performing the procedures. Read the chapter [Safety on page 19](#) before performing any service work.

The maintenance must be done by qualified personnel in accordance with the safety requirements set forth in the applicable national and regional standards and regulations.



Note

If the IRB 460 is connected to power, always make sure that the IRB 460 is connected to protective earth and a residual current device (RCD) before starting any maintenance work.

For more information see:

- *Product manual - OmniCore V250XT Type A*
- *Product manual - OmniCore V250XT Type B*
- *Product manual - OmniCore V400XT*
- *Product manual - IRC5*
- *Product manual - IRC5 Compact*
- *Product manual - IRC5 Panel Mounted Controller*
- [Robot cabling and connection points on page 92.](#)

3 Maintenance

3.2.1 Specification of maintenance intervals

3.2 Maintenance schedule and expected component life

3.2.1 Specification of maintenance intervals

Introduction

The intervals are specified in different ways depending on the type of maintenance activity to be carried out and the working conditions of the IRB 460:

- Calendar time: specified in months regardless of whether the system is running or not.
- Operating time: specified in operating hours. More frequent running means more frequent maintenance activities.
- SIS: specified by the robot's SIS (Service Information System). A typical value is given for a typical work cycle, but the value will differ depending on how hard each part is run.

The SIS used in M2004 is further described in the *Operating manual - Service Information System*.

The SIS used in OmniCore is further described in the *Operating manual - OmniCore*.

Robots with the functionality *Service Information System* activated can show active counters in the device browser in RobotStudio, or on the FlexPendant.

Overhaul

Depending on application and operational environment a complete overhaul may be necessary in average around 40000 hours.

ABB Connected Services and its Assessment tools can help you to identify the real stress level of your robot, and define the optimal ABB support to maintain your robot working.

Contact your local ABB Customer Service to get more information.

3.2.2 Maintenance schedule

General

The robot must be maintained regularly to ensure proper function. The maintenance activities and intervals are specified in the table below.

Non-predictable situations also give rise to inspections of the robot. Any damage must be attended to immediately.

The inspection intervals *do not* specify the life of each component. Values for these are specified in the section [Expected component life on page 103](#)

Instructions for how to perform the different maintenance activities are found in sections:

- [Inspection activities on page 104](#)
- [Replacement/changing activities on page 123](#)
- [Cleaning activities on page 138](#)

Activities and intervals, standard equipment

The table below specifies the required maintenance activities and intervals.

Maintenance activity	Equipment	Interval
Cleaning	Robot	-
Inspection	Axis-1 gearbox, oil level	Every: <ul style="list-style-type: none"> • 6 months
Inspection	Axes-2 and -3 gearboxes, oil level	Every: <ul style="list-style-type: none"> • 6 months
Inspection	Axis-6 gearbox, oil level	Every: <ul style="list-style-type: none"> • 6 months
Inspection	Robot harness	Every: <ul style="list-style-type: none"> • 12 monthsⁱ
Inspection	Information labels	Every: <ul style="list-style-type: none"> • 12 months
Inspection	Mechanical stop, axis 1	Every: <ul style="list-style-type: none"> • 12 months
	Mechanical stop, axis 3 (only applicable for IRB 760 - 445/3.2)	Every: <ul style="list-style-type: none"> • 12 months
Inspection	Dampers	Every: <ul style="list-style-type: none"> • 12 months
Changing	Axis-1 gear oil	First change when DTC ⁱⁱ reads: <ul style="list-style-type: none"> • 6,000 hours Second change when DTC ⁱⁱ reads: <ul style="list-style-type: none"> • 20,000 hours Following changes: <ul style="list-style-type: none"> • Every 20,000 hours

Continues on next page

3 Maintenance

3.2.2 Maintenance schedule

Continued

Maintenance activity	Equipment	Interval
Changing	Axis 2 gear oil	First change when DTC ⁱⁱ reads: <ul style="list-style-type: none"> • 6,000 hours Second change when DTC ⁱⁱ reads: <ul style="list-style-type: none"> • 20,000 hours Following changes: <ul style="list-style-type: none"> • Every 20,000 hours
Changing	Axis-3 gear oil	First change when DTC ⁱⁱ reads: <ul style="list-style-type: none"> • 6,000 hours Second change when DTC ⁱⁱ reads: <ul style="list-style-type: none"> • 20,000 hours Following changes: <ul style="list-style-type: none"> • Every 20,000 hours
Changing	Axis-6 gear oil	First change when DTC ⁱⁱ reads: <ul style="list-style-type: none"> • 6,000 hours Second change when DTC ⁱⁱ reads: <ul style="list-style-type: none"> • 20,000 hours Following changes: <ul style="list-style-type: none"> • Every 20,000 hours
Overhaul	Robot	30,000 hours
Replacement	Battery pack, measurement system of type RMU101 or RMU102 (3-pole battery contact)	36 months or battery low alert ⁱⁱⁱ
Replacement	Battery pack, measurement system with 2-pole battery contact, e.g. DSQC633A	Battery low alert ^{iv}

ⁱ Replace when damage or cracks are detected or life limit is approaching as specified in section [Expected component life on page 103](#).

ⁱⁱ DTC = Duty Time Counter. Shows the operational time of the robot.

ⁱⁱⁱ The battery low alert (38213 **Battery charge low**) is displayed when the battery needs to be replaced. The recommendation to avoid an unsynchronized robot is to keep the power to the controller turned on until the battery is to be replaced.

See the replacement instruction for more details.

^{iv} The battery low alert (38213 **Battery charge low**) is displayed when remaining backup capacity (robot powered off) is less than 2 months. The typical lifetime of a new battery is 36 months if the robot is powered off 2 days/week or 18 months if the robot is powered off 16 h/day. The lifetime can be extended with a battery shutdown service routine. See the operating manual for the robot controller for instructions.

Activities and intervals, optional equipment

The table below specifies the required maintenance activities and intervals for common optional equipment. The maintenance of other external equipment for the robot is detailed in separate documentation.

Maintenance activity	Equipment	Interval
Inspection	Signal lamp	Every: 12 months

3.2.3 Expected component life

General

The expected life of a specific component of the robot can vary greatly depending on how hard it is run.

Expected component life

Component	Expected life	Note
Cable harness	30,000 hours ⁱ	Optional upper arm harnesses not included.
Gearboxes ⁱⁱ	30,000 hours	

ⁱ Severe chemical or thermal environments, or similar environments, can result in shortened life expectancy.

ⁱⁱ Depending on application, the lifetime can vary. The Service Information System (SIS) that is integrated in the robot software can be used as guidance when planning gearbox service for the individual robot. This applies to gearboxes on axes 1, 2, 3 and 6. In some applications, such as Foundry or Washing, the robot can be exposed to chemicals, high temperature or humidity, which can have an effect on the lifetime of the gearboxes. Contact the local *ABB Robotics Service team* for more information.

The SIS for an M2004 system is described in the *Operating manual - Service Information System*.

3 Maintenance

3.3.1 Inspecting the oil level in axis-1 gearbox

3.3 Inspection activities

3.3.1 Inspecting the oil level in axis-1 gearbox

Location of gearbox

The axis-1 gearbox is located between the frame and base. See oil plugs in the following figure.

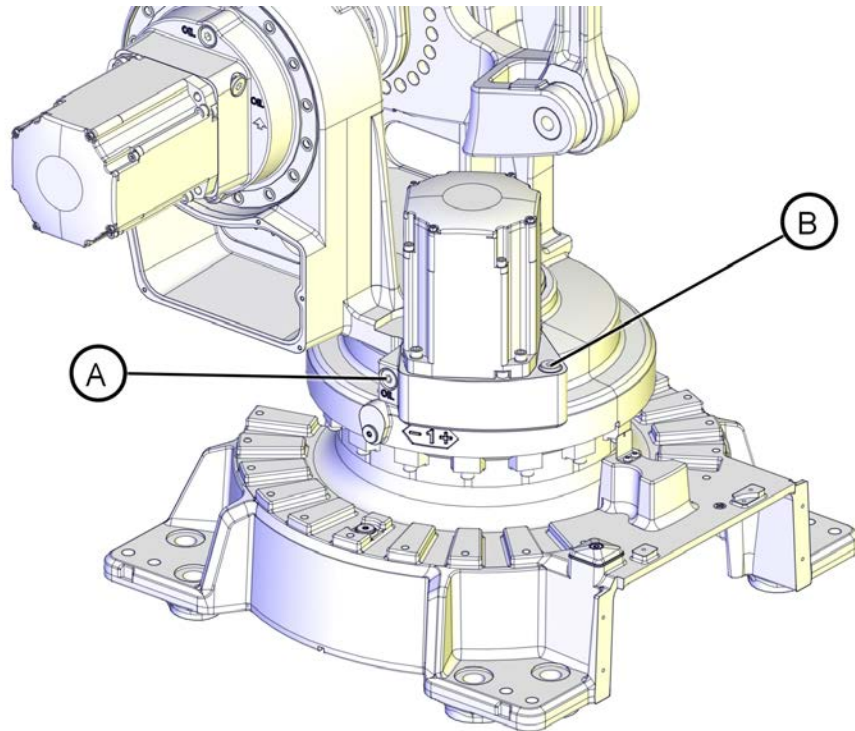

xx1000001294

A	Oil plug, inspection
B	Oil plug, filling



Required equipment

Equipment	Art. no.	Note
Lubricating oil	See <i>Type and amount of oil in gearboxes on page 123.</i>	 Note Do not mix with other oils!
Standard toolkit	-	Content is defined in section <i>Standard tools on page 398.</i>
Other tools and procedures may be required. See references to these procedures in the step-by-step instructions below.		These procedures include references to the tools required.

Continues on next page

Inspecting the oil level in axis-1 gearbox

Use this procedure to inspect the oil level in the axis-1 gearbox.

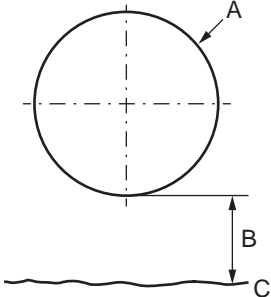
	Action	Note
1	 WARNING Handling gearbox oil involves several safety risks, see Gearbox lubricants (oil or grease) on page 34 .	
2	 DANGER Turn off all: <ul style="list-style-type: none"> • electric power supply • hydraulic pressure supply • air pressure supply to the robot, before entering the safeguarded space.	
3	Make sure that the oil temperature is $+25^{\circ}\text{C} \pm 10^{\circ}\text{C}$.	This is a precaution to reduce the temperature dependency of the measurement.
4	Open the <i>oil plug, inspection</i> .	Shown in figure Location of gearbox on page 104 .
5	Measure the oil level. Required oil level: max. 5 mm below the oil plug hole.	 <p>xx1400002785</p> <p>A Oil plug hole B Required oil level C Gearbox oil</p>
6	Adjust the oil level, if required.	Where to find type of oil and total amount is detailed in Type of lubrication in gearboxes on page 123 . Further information about how to fill with oil is found in section Changing oil, axis-1 gearbox on page 124 .
7	Refit the oil plug.	Tightening torque: 25 Nm

3 Maintenance

3.3.2 Inspecting, oil level gearbox axes 2 - 3

3.3.2 Inspecting, oil level gearbox axes 2 - 3

Location of gearbox, axes 2-3

The gearboxes axes 2-3 are located in the lower arm rotational center, underneath the motor attachment.

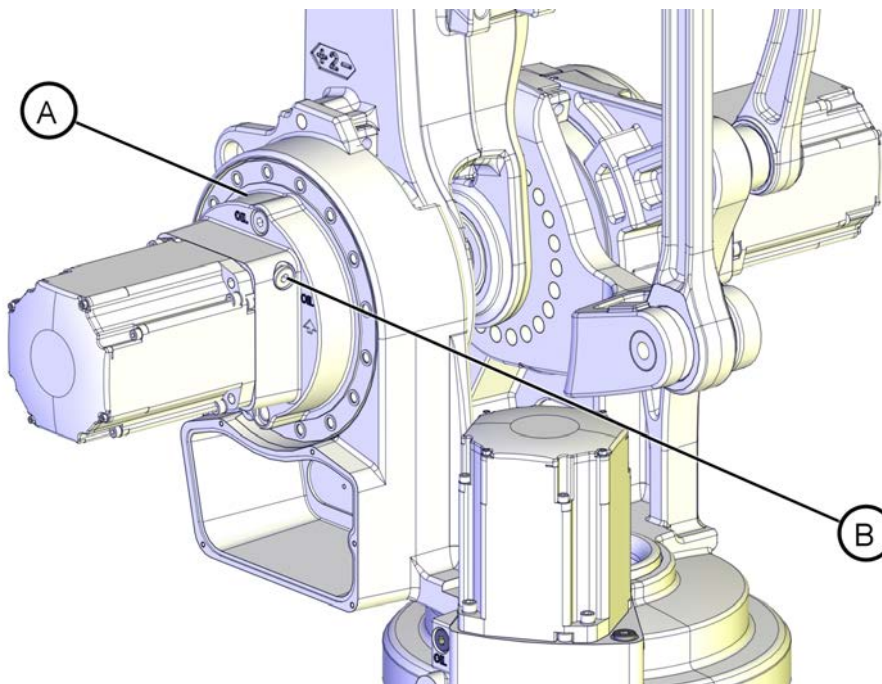

xx1000001295

A	Gearbox, axis 2
B	Oil plug, filling

Continues on next page

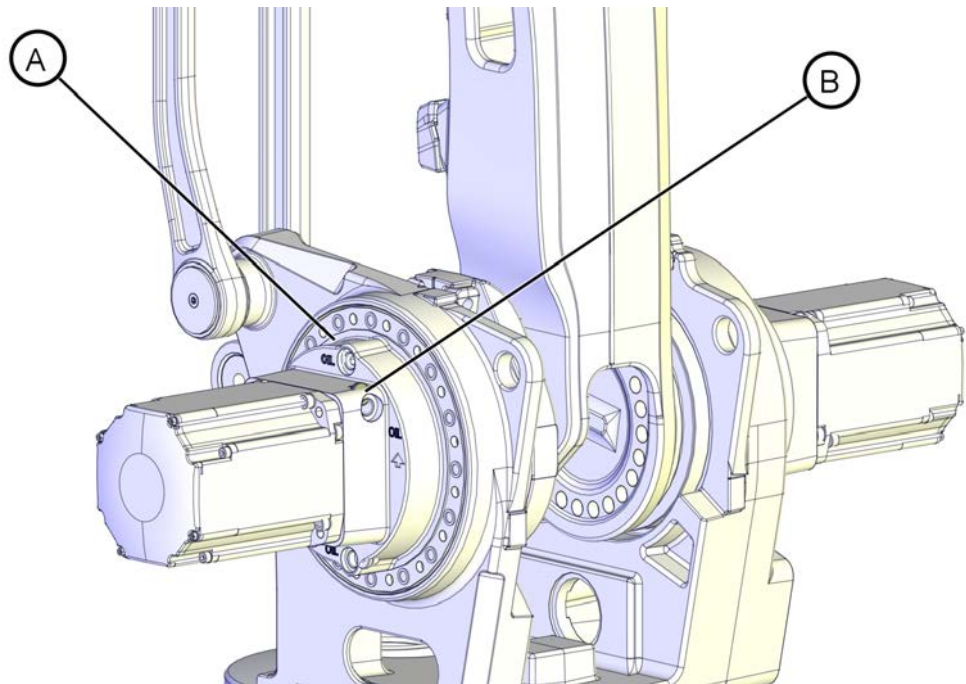

xx1000001297

A	Gearbox, axis 3
B	Oil plug, filling

Required equipment

Equipment etc.	Art.no.	Note
Lubricating oil	See <i>Type and amount of oil in gearboxes on page 123.</i>	 Note Do not mix with other oils!
Standard toolkit	-	Content is defined in section <i>Standard tools on page 398.</i>
Other tools and procedures may be required. See references to these procedures in the step-by-step instructions below		These procedures include references to the tools required.

Inspecting, oil level gearbox 2 - 3

Use this procedure to inspect the oil level in gearbox axes 2 - 3.

	Action	Note
1	 WARNING Handling gearbox oil involves several safety risks, see <i>Gearbox lubricants (oil or grease) on page 34.</i>	

Continues on next page

3 Maintenance

3.3.2 Inspecting, oil level gearbox axes 2 - 3

Continued

	Action	Note
2	 DANGER Turn off all: <ul style="list-style-type: none">• electric power supply• hydraulic pressure supply• air pressure supply to the robot, before entering the safeguarded space.	
3	Open <i>oil plug, filling</i>	See Location of gearbox, axes 2-3 on page 106 .
4	Measure oil level at the oil plug, filling. Required oil level: max. 5 mm below oil plug hole.	
5	Add <i>oil</i> if required.	Art.no. is specified in Required equipment on page 107 . Filling of oil is detailed further in section Changing oil, gearbox axes 2 and 3 on page 128 .
6	Refit oil plug, filling.	Tightening torque: 25 Nm.

3.3.3 Inspecting, oil level gearbox axis 6

Location of gearbox

The axis 6 gearbox is located in the tilthouse unit as shown in this figure.

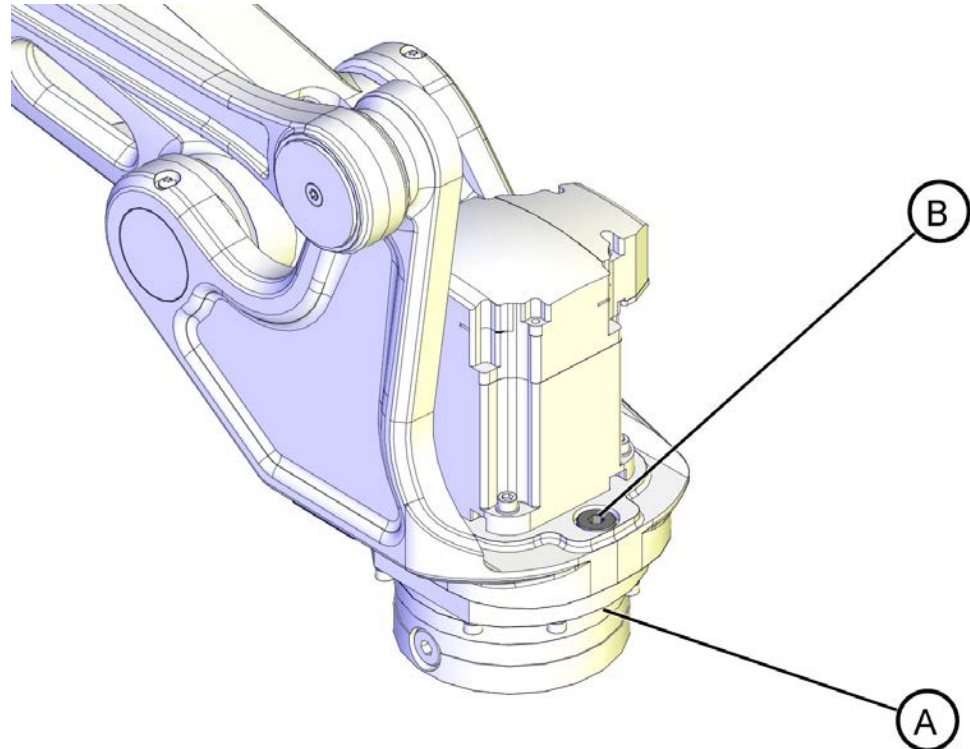

xx1000001301

A	Gearbox, axis 6
B	Oil plug, filling

Required equipment

Equipment	Art. no.	Note
Lubricating oil	3HAC032140-001	Kyodo Yushi TMO 150
Standard toolkit	-	Content is defined in section Standard tools on page 398 .
Other tools and procedures may be required. See references to these procedures in the step-by-step instructions below.		These procedures include references to the tools required.

Continues on next page



3 Maintenance

3.3.3 Inspecting, oil level gearbox axis 6

Continued

Inspection, oil level axis-6 gearbox

Use this procedure to inspect the oil level in the axis-6 gearbox.

	Action	Note
1	 WARNING Handling gearbox oil involves several safety risks, see Gearbox lubricants (oil or grease) on page 34 .	
2	 DANGER Turn off all: <ul style="list-style-type: none">• electric power supply• hydraulic pressure supply• air pressure supply to the robot, before entering the safeguarded space.	
3	Open <i>oil plug, filling</i> .	Shown in figure Location of gearbox on page 109 .
4	Required oil level: 23 mm ± 2 mm below the motor mounting surface.	
5	Add <i>oil</i> if required.	Art. no. is specified in Required equipment on page 109 . Further information about how to fill the oil may be found in the section Changing oil, gearbox axis 6 on page 132 .
6	Refit oil plug, filling.	Tightening torque: 24 Nm

3.3.4 Inspecting, cable harness

Location of cable harness, axes 1-6

The axes-1-6 cable harness is shown below.

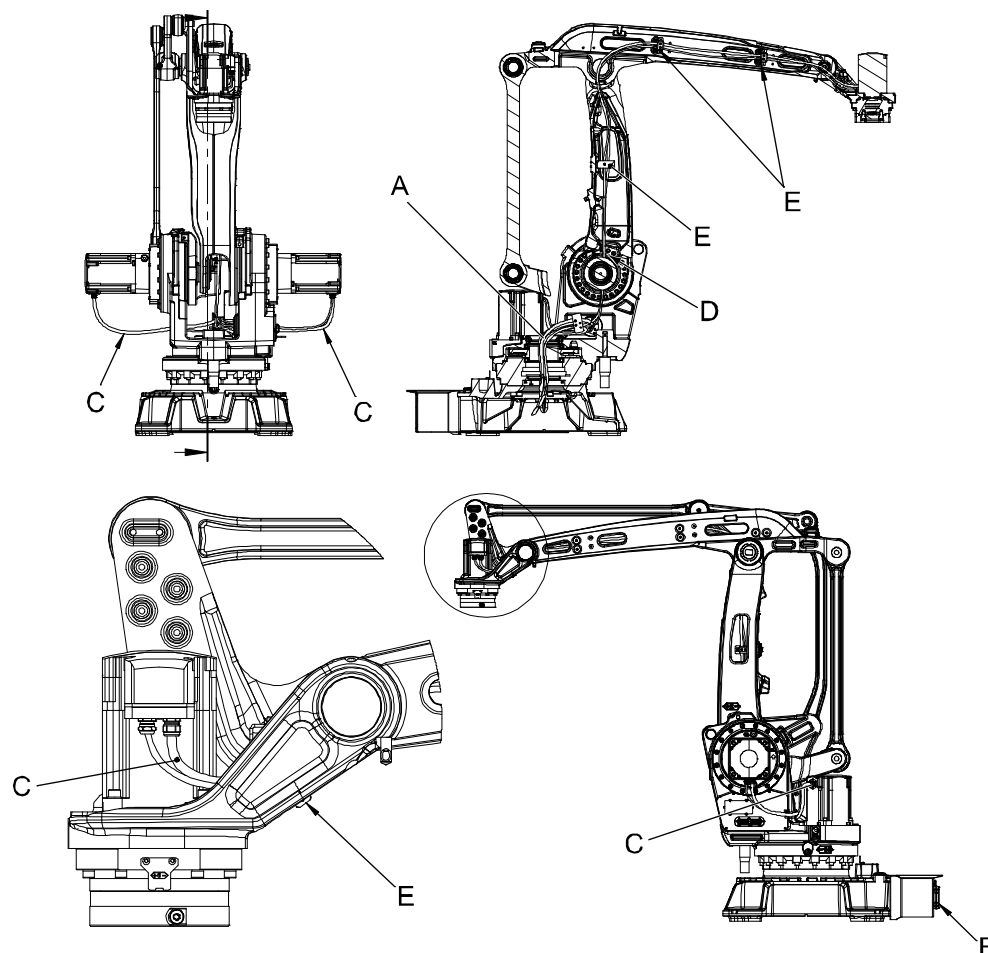

xx1000001373

A	Cable harness robot, axes 1-6
B	Connectors at base
C	Motor cables
D	Cable guide, axis 2
E	Metal clamps

Required equipment

Visual inspection, no tools are needed.

Continues on next page

3 Maintenance

3.3.4 Inspecting, cable harness

Continued

Inspecting cable harness, axes 1-6

Use this procedure to inspect cable harness of axes 1-6.

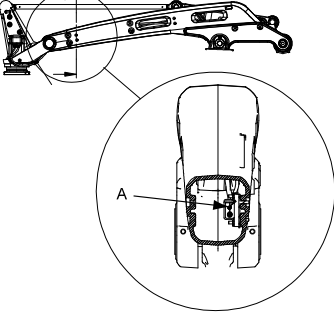
	Action	Note
1	 <p>DANGER</p> <p>Turn off all:</p> <ul style="list-style-type: none"> • electric power supply • hydraulic pressure supply • air pressure supply <p>to the robot, before entering the safeguarded space.</p>	
2	Make an overall inspection of the cable harness in order to detect wear and damage.	
3	Check the <i>connectors at the base</i> .	Shown in figure Location of cable harness, axes 1-6 on page 111
4	Check the <i>motor cables</i> .	Shown in figure Location of cable harness, axes 1-6 on page 111 .
5	Check the <i>cable guide axis 2</i> . Replace if damaged.	Shown in figure Location of cable harness, axes 1-6 on page 111 .
6	Check the <i>metal clamps</i> on the lower arm.	Shown in figure Location of cable harness, axes 1-6 on page 111
7	Check the metal clamps holding the cable harness inside the upper arm, as shown in figure to the right.	 <p>xx0500002498</p> <p>A: Metal clamp inside upper arm</p>
8	Check the metal clamp holding the motor cable on axis 6.	Shown in figure Location of cable harness, axes 1-6 on page 111 .
9	Replace the cable harness if wear or damage is detected!	Detailed in section: Replacing cable harness, lower end (axes 1-3) on page 151. Replacing the cable harness, upper end (incl. axis 6) on page 161.

3.3.5 Inspecting the information labels

Location of labels

These figures show the location of the information labels to be inspected. The symbols are described in section [Safety symbols on manipulator labels on page 23](#).

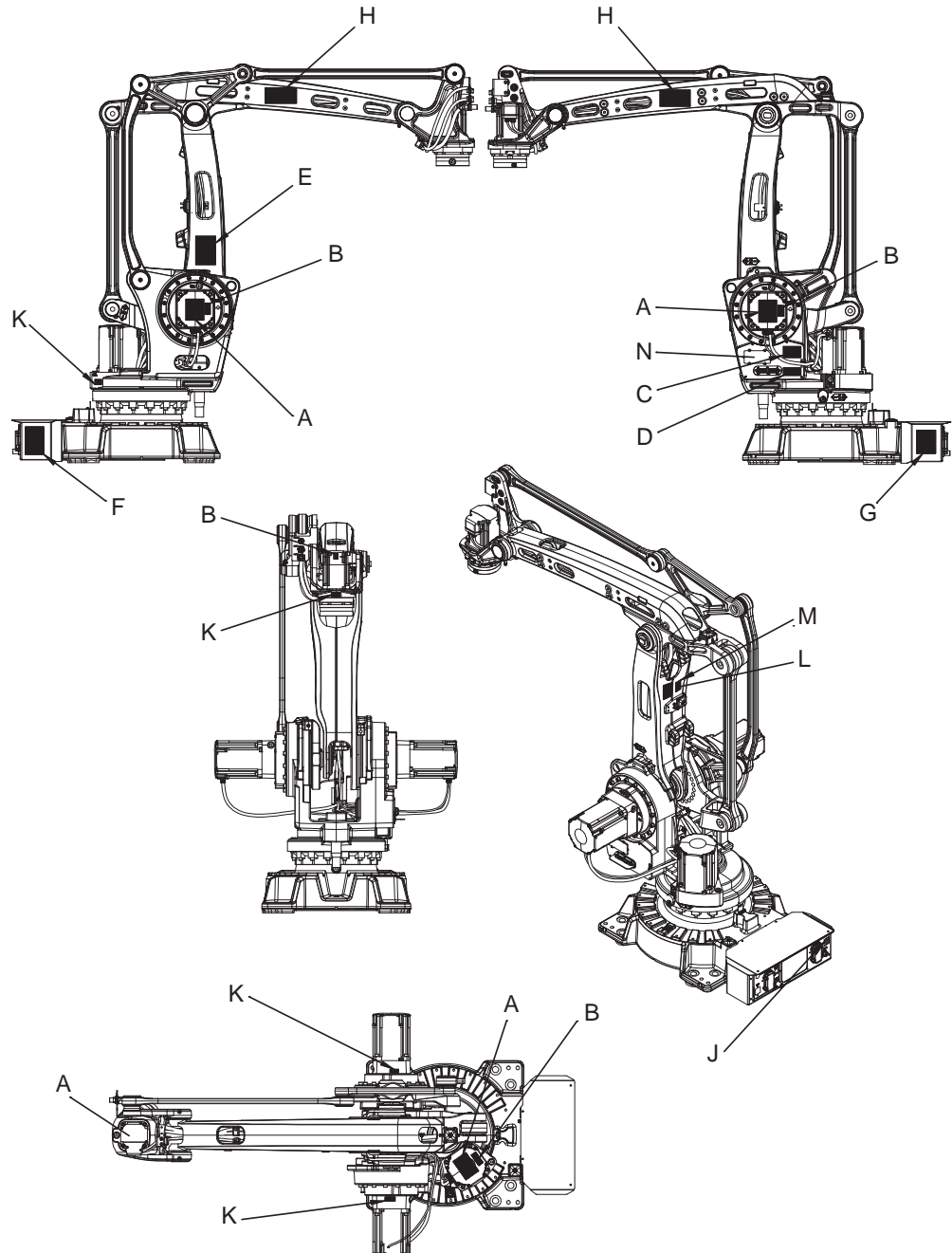

xx1000001292

A	Warning label "Heat" (located on motor cover), 3HAC4431-1 (4 pcs)
B	Warning label, symbol of flash (located on motor cover), 3HAC1589-1 (4 pcs)
C	Combined warning label "Moving robot", "Shut off with handle" and "Before dismantling see product manual", 3HAC17804-1

Continues on next page

3 Maintenance

3.3.5 Inspecting the information labels

Continued

D	Combined warning label "Brake release", "Brake release buttons" and "Moving robot", 3HAC054583-001
E	Instruction label for lifting of robot, 3HAC039135-001
F	Warning label "Tip risk when loosening bolts", 3HAC9191-1
G	Information label at base, specifying which oil is filled in gearboxes, 3HAC032906-001
H	ABB Logotype, 3HAC17765-2 (2 pcs)
J	UL label, 3HAC2763-1
K	Information label near each gearbox, specifying which oil is used in gearboxes, 3HAC032726-001 (4 pcs)
L	Label serial number
M	Label calibration
N	Label, battery
P	Label, stock robots

Required tools and equipment

Visual inspection, no tools are required.

Inspecting, labels

	Action	Note
1	 DANGER Turn off all: <ul style="list-style-type: none">• electric power supply• hydraulic pressure supply• air pressure supply to the robot, before entering the safeguarded space.	
2	Inspect the labels, located as shown in the figures.	
3	Replace any missing or damaged labels.	Article numbers for the labels and plate set is specified in Spare parts on page 403 .

3.3.6 Inspecting the axis-1 mechanical stop pin



WARNING

For robots with IRC5 controllers

Mechanical stop pin can not be fitted onto robot if option 810-1 *Electronic Position Switch* is used.

Location of mechanical stop pin

The axis-1 mechanical stop is located as shown in the figure.

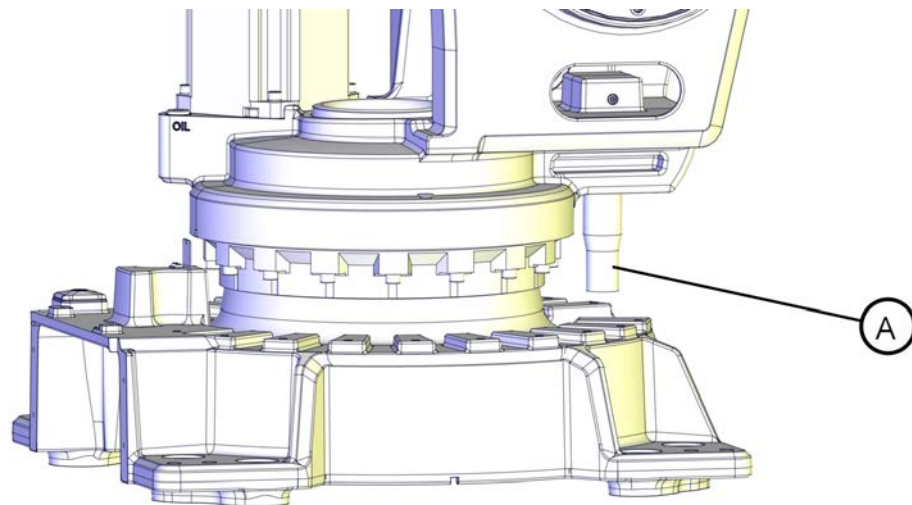

xx1000001302

A	Mechanical stop pin, axis 1
---	-----------------------------

Required equipment

Visual inspection, no tools are required.

Inspecting, mechanical stop pin

Use this procedure to inspect the axis-1 mechanical stop pin.

	Action	Note
1	<p>DANGER</p> <p>Turn off all:</p> <ul style="list-style-type: none"> • electric power supply • hydraulic pressure supply • air pressure supply <p>to the robot, before entering the safeguarded space.</p>	

Continues on next page

3 Maintenance

3.3.6 Inspecting the axis-1 mechanical stop pin

Continued

	Action	Note
2	<p>Inspect the axis-1 mechanical stop pin. If the mechanical stop pin is bent or damaged, it must be replaced.</p> <p> Note</p> <p>The expected life of gearboxes can be reduced after collision with the mechanical stop.</p>	

3.3.7 Inspecting the additional mechanical stops

Location of mechanical stops

This figure shows the location of the additional mechanical stop on axis 1.

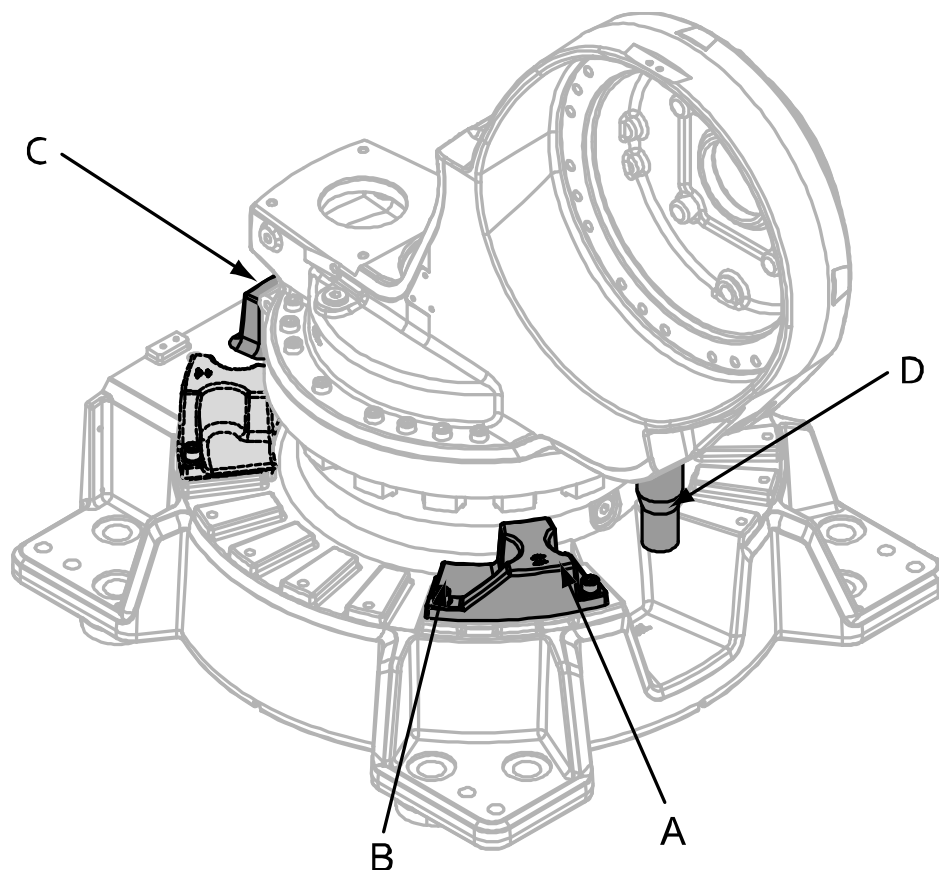

xx0600002938

A	Additional stop, axis 1
B	Attachment screws and washers (2 pcs)
C	Fixed stop
D	Mechanical stop pin, axis 1

Required equipment

Equipment etc.	Article number	Note
Mechanical stop	See Spare parts on page 403 .	
Standard toolkit	-	Content is defined in section Standard tools on page 398 .

Continues on next page

3 Maintenance

3.3.7 Inspecting the additional mechanical stops

Continued

Inspecting, mechanical stops

Use this procedure to inspect the additional mechanical stops.

	Action	Note
1	 DANGER Turn off all: <ul style="list-style-type: none">• electric power supply• hydraulic pressure supply• air pressure supply to the robot, before entering the robot working area.	
2	Make sure no additional stops are damaged.	Shown in figure Location of mechanical stops on page 117 .
3	Make sure the stops are properly attached. Correct tightening torque, additional mechanical stops: <ul style="list-style-type: none">• Axis 1 = 120 Nm.	
4	If any damage is detected, the mechanical stops must be replaced. Correct attachment screws: <ul style="list-style-type: none">• Axis 1: M12 x 40, quality 12.9.	Article number is specified in Required equipment on page 117 .

3.3.8 Inspection, dampers

Location of dampers

This figure shows the location of dampers.

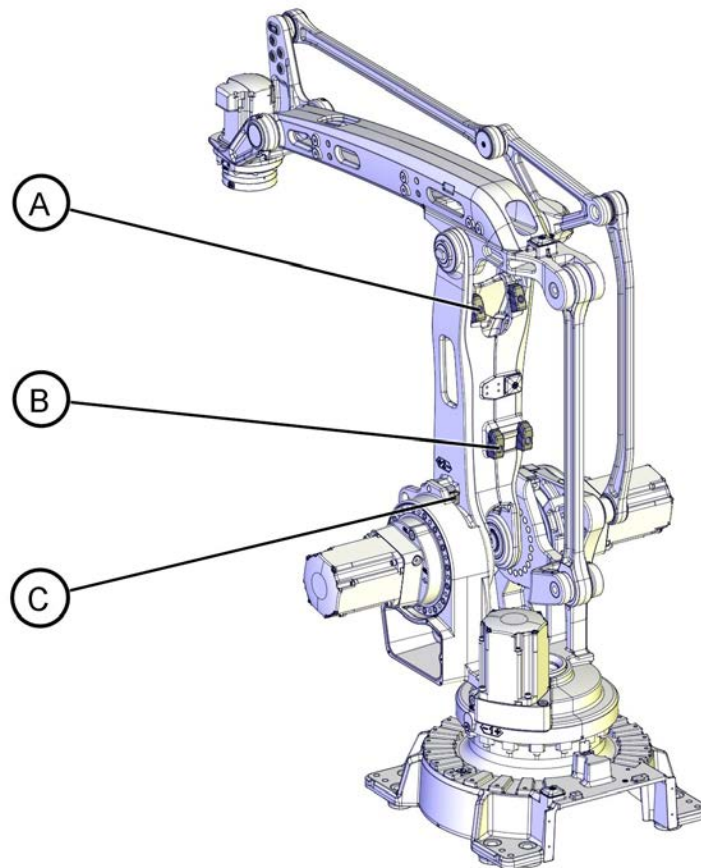

xx1000001345

A	Damper, lower arm, upper (2 pcs)
B	Damper, lower arm, lower (2 pcs)
C	Damper, axis 2 (2 pcs)
-	Damper, axis 3 (2 pcs). Not visible in this view.

Required equipment

Equipment	Art.no.	Note
Damper lower arm, upper	See Spare parts on page 403 .	To be replaced if damaged.
Damper lower arm, lower	See Spare parts on page 403 .	To be replaced if damaged.
Damper axis 2, 3	See Inspection, dampers on page 119 .	To be replaced if damaged.

Continues on next page

3 Maintenance

3.3.8 Inspection, dampers

Continued

Inspecting, dampers

Use this procedure to inspect the dampers.

	Action	Note
1	 DANGER Turn off all: <ul style="list-style-type: none">• electric power supply• hydraulic pressure supply• air pressure supply to the robot, before entering the safeguarded space.	
2	Check all <i>dampers</i> for damage, cracks or existing impressions larger than 1 mm.	Shown in figure Location of dampers on page 119 .
3	Check attachment screws for deformation.	
4	If any damage is detected, the <i>damper</i> must be replaced with a new one.	Art.no. is specified in Required equipment on page 119 .

3.3.9 Inspecting the signal lamp (option)

Location of signal lamp

The signal lamp is located as shown in this figure.

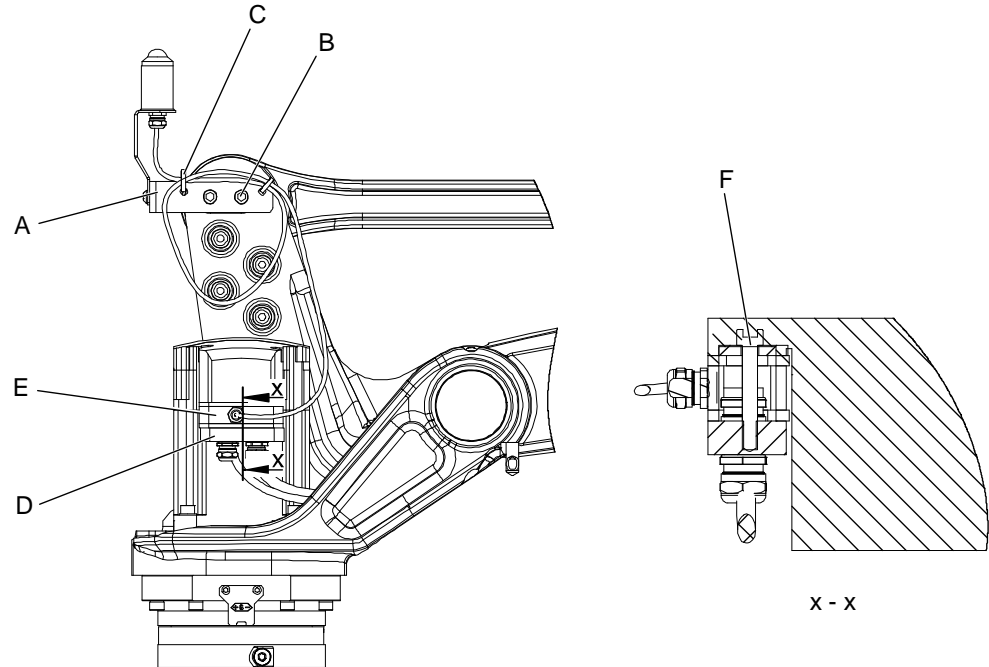

xx1000001288

A	Signal lamp bracket
B	Attachment screws, M8x12 and bracket (2 pcs)
C	Cable straps (2 pcs)
D	Cable gland cover
E	Motor adapter including gasket
F	Attachment screw, M6x40 (1 pc)

Required tools and equipment

Equipment	Article number	Note
Signal lamp kit	See Spare parts on page 403 .	To be replaced if damage is detected.
Standard toolkit	-	Content is defined in section Standard tools on page 398 .

Inspecting, signal lamp

Use this procedure to inspect the function of the signal lamp.

	Action	Note
1	Inspect that signal lamp is lit when motors are put in operation ("MOTORS ON").	

Continues on next page

3 Maintenance

3.3.9 Inspecting the signal lamp (option)

Continued

	Action	Note
2	 DANGER Turn off all: <ul style="list-style-type: none">• electric power supply• hydraulic pressure supply• air pressure supply to the robot, before entering the safeguarded space.	
3	If the lamp is not lit, trace the fault by: <ul style="list-style-type: none">• inspecting whether the signal lamp is broken. If so, replace it.• inspecting cable connections.• measuring the voltage in the connectors of motor axis 6 (=24V).• inspecting the cabling. Replace the cabling if a fault is detected.	Article number is specified in Required tools and equipment on page 121 .

3.4 Replacement/changing activities

3.4.1 Type of lubrication in gearboxes

Introduction

This section describes where to find information about the type of lubrication, article number and the amount of lubrication in the specific gearbox. It also describes the equipment needed when working with lubrication.

Type and amount of oil in gearboxes

Information about the type of lubrication, article number as well as the amount in the specific gearbox can be found in *Technical reference manual - Lubrication in gearboxes* available for registered users on myABB Business Portal, www.abb.com/myABB.

Location of gearboxes

The figure shows the location of the gearboxes.

Equipment

Equipment	Note
Oil dispenser	Includes pump with outlet pipe. Use the suggested dispenser or a similar one: <ul style="list-style-type: none"> • Orion OriCan article number 22590 (pneumatic)
Nipple for quick connect fitting, with o-ring	

3 Maintenance

3.4.2 Changing oil, axis-1 gearbox

3.4.2 Changing oil, axis-1 gearbox

Location of oil plugs

The axis-1 gearbox is located between the frame and base. See oil plugs in the following figure.

The oil is drained through a hose, which is located at the rear of the robot base.

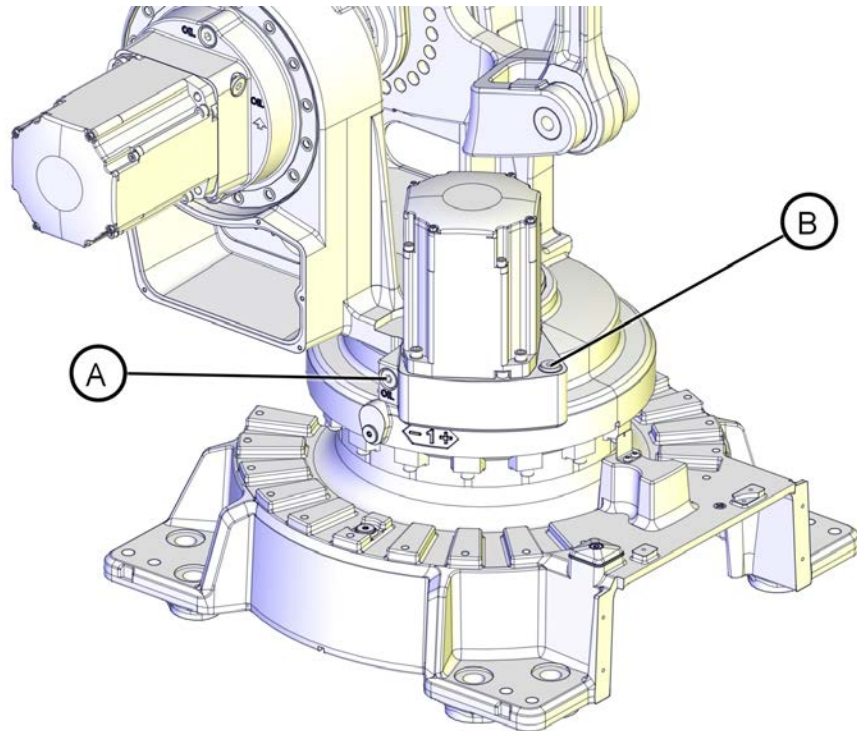

xx1000001294

A	Oil plug, inspection
B	Oil plug, filling

Continues on next page

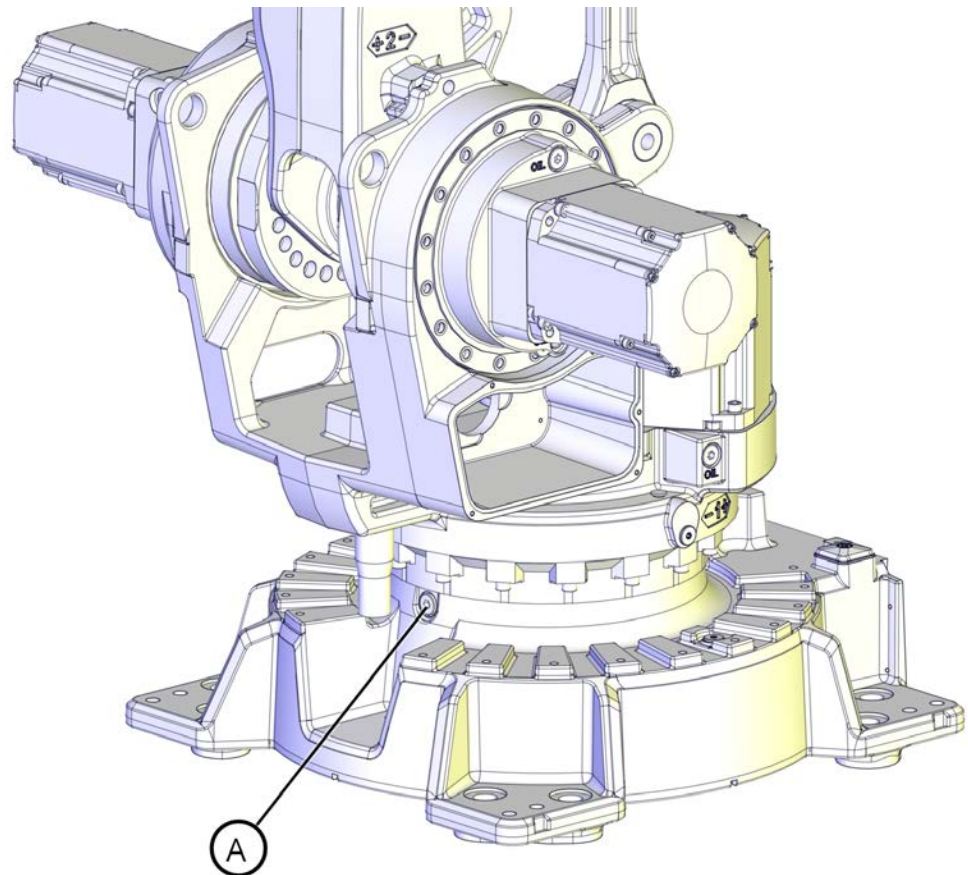

xx100001346

A	Oil plug, draining
---	--------------------

Required equipment

Equipment, etc.	Art. no.	Amount	Note
Lubricating oil	See <i>Type and amount of oil in gearboxes on page 123.</i>	See <i>Type and amount of oil in gearboxes on page 123.</i>	 Note Do not mix with other oils!
Oil collecting vessel	-		Capacity: 8,000 ml.
Oil exchange equipment	3HAC021745-001		Content is defined in section <i>Special tools on page 399.</i>
Standard toolkit	-		Content is defined in section <i>Standard tools on page 398.</i>

Continues on next page



3 Maintenance

3.4.2 Changing oil, axis-1 gearbox

Continued



Draining oil, axis-1 gearbox

Use this procedure to drain oil in gearbox axis 1.

	Action	Note
1	 DANGER Turn off all: <ul style="list-style-type: none"> • electric power supply • hydraulic pressure supply • air pressure supply to the robot, before entering the safeguarded space.	
2	 WARNING Handling gearbox oil involves several safety risks, see Gearbox lubricants (oil or grease) on page 34 .	
3	Remove <i>oil plug, filling</i> , in order to drain oil quicker!	Shown in Location of oil plugs on page 124 .
4	Remove <i>oil plug, draining</i> , and drain gearbox using a hose with a nipple and an oil collecting vessel.	Shown in Location of oil plugs on page 124 . Vessel capacity is specified in Required equipment on page 125 .  Note Draining is time-consuming. Elapsed time depends on the temperature of the oil.
5	Refit oil plugs.	Tightening torque: 25 Nm.

Filling oil, axis-1 gearbox

Use this procedure to fill gearbox axis 1 with oil.

	Action	Note
1	 DANGER Turn off all: <ul style="list-style-type: none"> • electric power supply • hydraulic pressure supply • air pressure supply to the robot, before entering the safeguarded space.	
2	 WARNING Handling gearbox oil involves several safety risks, see Gearbox lubricants (oil or grease) on page 34 .	
3	Open the <i>oil plug, filling</i> .	Shown in figure Location of oil plugs on page 124 .

Continues on next page

	Action	Note
4	Refill the gearbox with clean <i>lubricating oil</i> . The correct oil level is detailed in section <i>Inspecting the oil level in axis-1 gearbox on page 104</i> .	Where to find type of oil and total amount is detailed in <i>Type and amount of oil in gearboxes on page 123</i> .
5	Refit the oil plug, filling.	Tightening torque: 25 Nm.

3 Maintenance

3.4.3 Changing oil, gearbox axes 2 and 3

3.4.3 Changing oil, gearbox axes 2 and 3

Location of oil plugs

Gearboxes, axes 2 and 3, are located in lower arm rotational center, underneath motor attachment.

The figure shows the position of gearbox, axis 2.

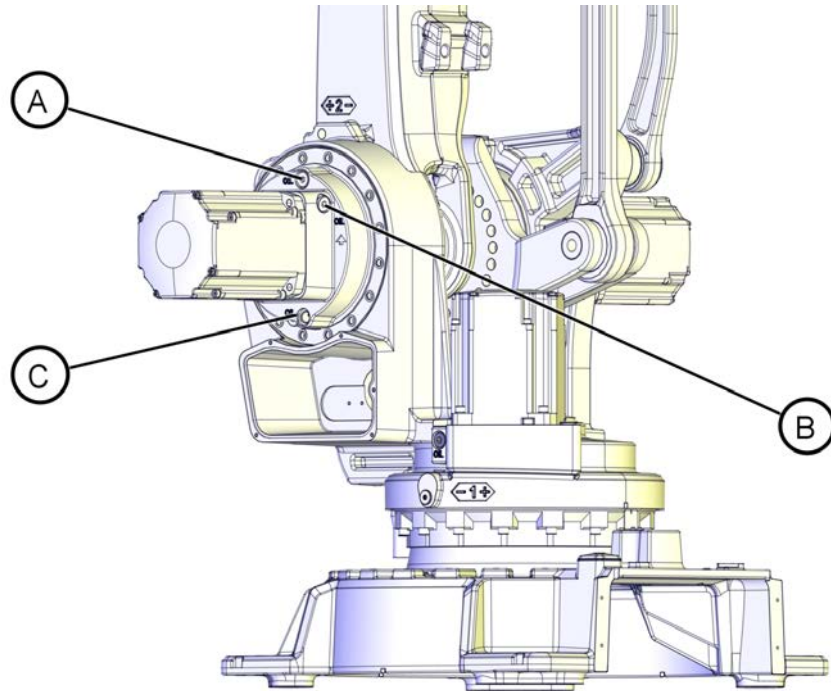

xx1000001348

A	Ventilation hole plug, gearbox axis 2
B	Oil plug, filling
C	Oil plug, draining

Continues on next page

The figure shows position of gearbox, axis 3.

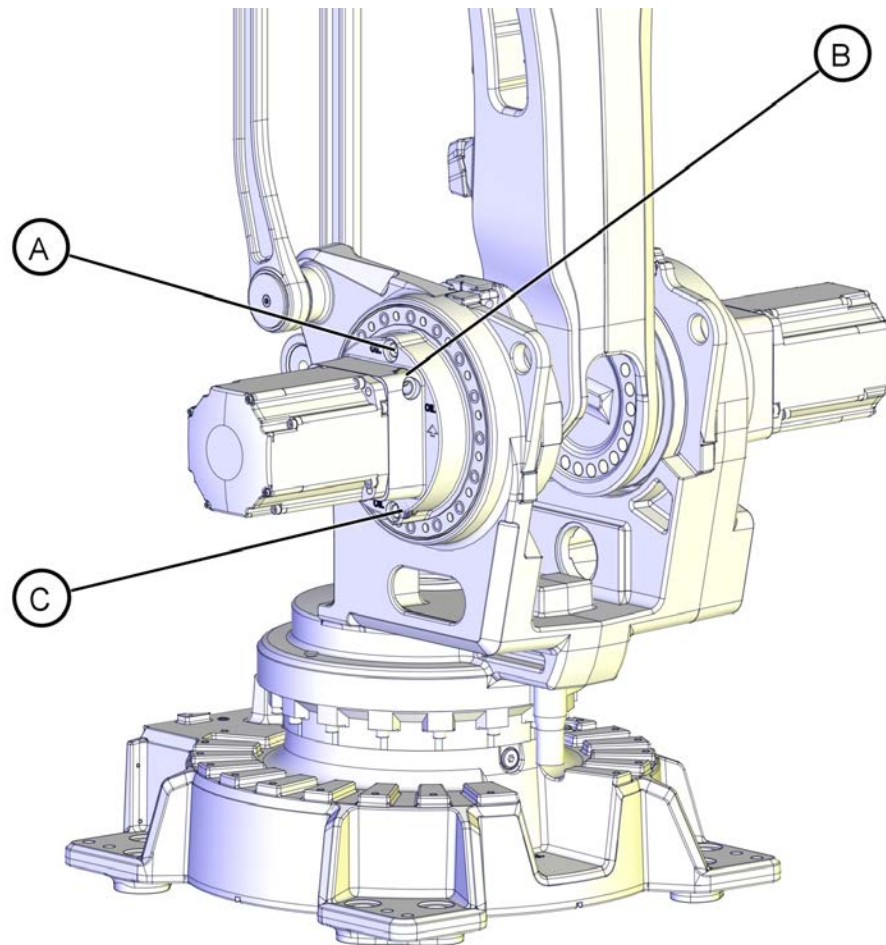

xx1000001351

A	Ventilation hole plug, gearbox axis 3
B	Oil plug, filling
C	Oil plug, draining

Required equipment

Equipment etc.	Art. no.	Amount	Note
Lubricating oil	See <i>Type and amount of oil in gearboxes on page 123.</i>	3,200 ml in each gearbox	 Note Do not mix with other oils!
Oil collecting vessel			Capacity: 4,000 ml
Oil exchange equipment	3HAC021745-001		Content is defined in section <i>Special tools on page 399.</i>
Standard toolkit	-		Content is defined in section <i>Standard tools on page 398.</i>

Continues on next page

3 Maintenance



3.4.3 Changing oil, gearbox axes 2 and 3

Continued

Draining, axes 2 and 3

Use this procedure to drain oil in gearbox axes 2 and 3.



When using oil change equipment, follow the instructions enclosed with kit.

	Action	Note
1	 DANGER Turn off all: <ul style="list-style-type: none"> • electric power supply • hydraulic pressure supply • air pressure supply to the robot, before entering the safeguarded space.	
2	 WARNING Handling gearbox oil involves several safety risks, see Gearbox lubricants (oil or grease) on page 34 .	
3	Remove the <i>ventilation hole plug</i> .	Shown in Location of oil plugs on page 128 .
4	Remove the <i>oil plug, draining</i> , and drain gearbox using a hose with a nipple and an oil collecting vessel.	Shown in Location of oil plugs on page 128 . Vessel capacity is specified in Required equipment on page 129 . Draining is time-consuming. Elapsed time varies depending on the temperature of the oil.
5	Refit the oil plug, draining.	Tightening torque: 25 Nm.

Filling, axes 2 and 3

Use this procedure to fill gearboxes of axes 2 and 3 with oil.

When using oil change equipment, follow the instructions enclosed with kit.

	Action	Note
1	 DANGER Turn off all: <ul style="list-style-type: none"> • electric power supply • hydraulic pressure supply • air pressure supply to the robot, before entering the safeguarded space.	
2	 WARNING Handling gearbox oil involves several safety risks, see Gearbox lubricants (oil or grease) on page 34 .	

Continues on next page

	Action	Note
3	Remove the <i>oil plug, filling</i> . (<i>Ventilation hole plug</i> should also be removed.)	Shown in Location of oil plugs on page 128 . Tightening torque: 24 Nm.
4	Refill gearbox with <i>lubricating oil</i> . The <i>amount of oil</i> to be filled depends on the amount that was previously drained.	Art.no. and total amount are specified in Required equipment on page 129 .
5	Refit <i>oil plug, filling</i> and <i>ventilation hole plug</i> .	Shown in Location of oil plugs on page 128 . Tightening torque: 25 Nm.

3 Maintenance

3.4.4 Changing oil, gearbox axis 6

3.4.4 Changing oil, gearbox axis 6

Location of oil plugs

Gearbox axis 6 is located in the center of the tilt house unit.

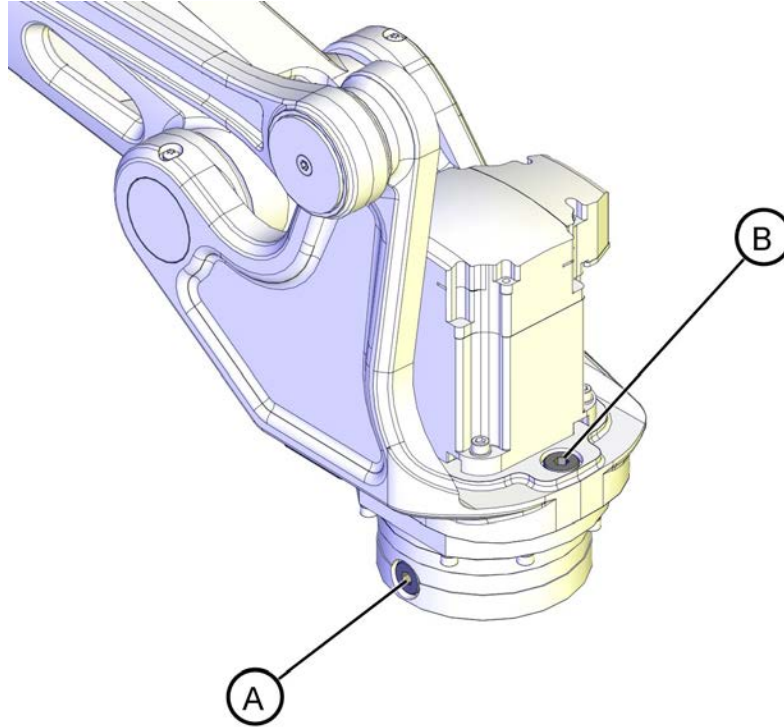

xx1000001353

A	Oil plug, draining
B	Oil plug, filling

Required equipment

Equipment, etc.	Art. no.	Amount	Note
Lubrication oil	3HAC032140-001	300 ml	Kyodo Yushi TMO 150 Do not mix with other oil types!
Oil exchange equipment	3HAC021745-001		
Oil collecting vessel			Vessel capacity: 400 ml.
Standard toolkit		-	Content is defined in section Standard tools on page 398.

Draining, oil

Use this procedure to drain oil from gearbox axis 6.

When using oil change equipment, follow the instructions enclosed with kit.

	Action	Note
1	Put tilt house in a suitable position.	

Continues on next page

	Action	Note
2	 DANGER Turn off all: <ul style="list-style-type: none"> • electric power supply • hydraulic pressure supply • air pressure supply to the robot, before entering the safeguarded space.	
3	Drain oil from gearbox into a vessel by removing <i>oil plug, draining</i> . Also remove <i>oil plug, filling</i> .	Shown in figure Location of oil plugs on page 132 . Vessel capacity is specified in Required equipment on page 132 .
4	Refit oil plugs, draining and filling.	Tightening torque: 24 Nm.

Filling, oil

Use this procedure to fill gearbox axis 6 with oil.

When using oil change equipment, follow the instructions enclosed with kit.

	Action	Note
1	 DANGER Turn off all: <ul style="list-style-type: none"> • electric power supply • hydraulic pressure supply • air pressure supply to the robot, before entering the safeguarded space.	
2	Remove the <i>oil plug, filling</i> .	Shown in figure Location of oil plugs on page 132 .
3	Refill the gearbox with <i>lubricating oil</i> . Amount of oil to be refilled depends on the amount that was previously drained. Correct oil level is detailed in section Inspection, oil level axis-6 gearbox on page 110 .	Art. no. and the total amount are specified in Required equipment on page 132 .
4	Refit the oil plug.	Tightening torque: 24 Nm.

3 Maintenance

3.4.5 Replacing the SMB battery

3.4.5 Replacing the SMB battery



Note

The battery low alert (38213 **Battery charge low**) is displayed when the battery needs to be replaced. The recommendation to avoid an unsynchronized robot is to keep the power to the controller turned on until the battery is to be replaced. For a SMB board with 3-pole battery contact (RMU101 3HAC044168-001 or RMU102 3HAC043904-001), the lifetime of a new battery is typically 36 months. For a SMB board with 2-pole battery contact (DSQC), the typical lifetime of a new battery is 36 months if the robot is powered off 2 days/week or 18 months if the robot is powered off 16 h/day. The lifetime can be extended for longer production breaks with a battery shutdown service routine. See the operating manual for the robot controller for instructions.



WARNING

See [Hazards related to batteries on page 36](#).

Location of SMB battery

The SMB battery (SMB = serial measurement board) is located on the left hand side of the frame as shown in the figure.

Battery pack with a 2-pole battery contact (DSQC)

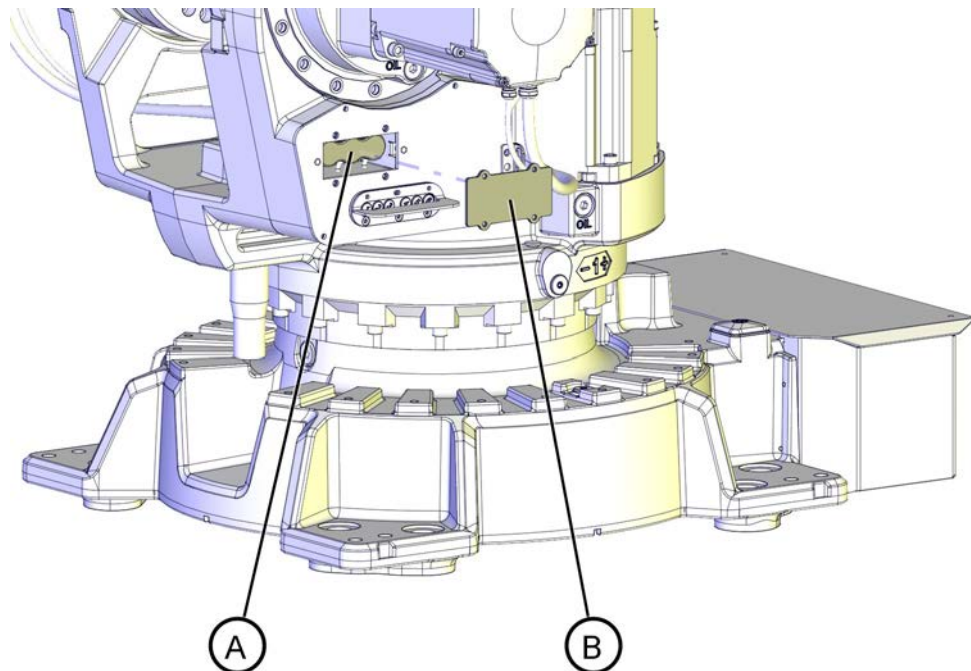

xx1000001360

A	SMB battery pack
B	SMB battery cover

Continues on next page

Battery pack with a 3-pole battery contact (RMU)

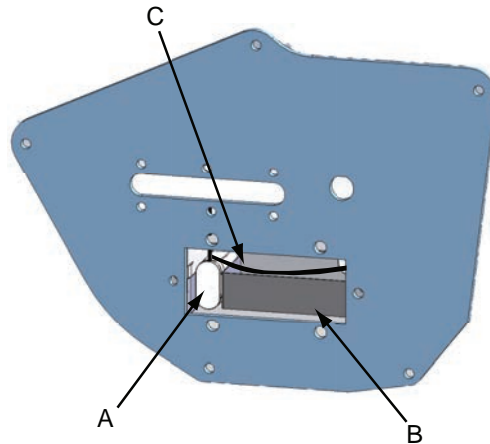

xx1300001116

- A Battery pack RMU
- B Battery holder
- C Battery cable

Required equipment



Note

There are two variants of SMB units and batteries. One with 2-pole battery contact (DSQC) and one with 3-pole battery contact (RMU). The variant with the 3-pole battery contact has longer lifetime for the battery.

It is important that the SMB unit uses the correct battery. Make sure to order the correct spare parts. Do not exchange battery contacts!

Equipment, etc.	Spare part no.	Note
Battery unit	For spare part no. see: <ul style="list-style-type: none"> • Spare parts on page 403 	Battery includes protection circuits. Only replace with a specified spare part or an ABB-approved equivalent.
Standard toolkit	-	Content is defined in section Standard tools on page 398 .
Circuit diagram	-	See chapter Circuit diagrams on page 405 .

Removing, battery

Use this procedure to remove the SMB battery.



	Action	Note
1	Move the robot to its calibration position.	This is done in order to facilitate updating of the revolution counter.

Continues on next page

3 Maintenance



3.4.5 Replacing the SMB battery

Continued



	Action	Note
2	 DANGER Turn off all: <ul style="list-style-type: none"> • electric power supply • hydraulic pressure supply • air pressure supply to the robot, before entering the safeguarded space.	
3	 ELECTROSTATIC DISCHARGE (ESD) The unit is sensitive to ESD. Before handling the unit please read the safety information in the section The unit is sensitive to ESD on page 51	
4	Remove the <i>SMB battery cover</i> by unscrewing the attachment screws.  CAUTION Clean cover from metal residues before opening. Metal residues can cause shortage on the boards which can result in hazardous failures.	Shown in figure Location of SMB battery on page 134 .
5	Pull out the battery and disconnect the <i>battery cable</i> .	Shown in figure Location of SMB battery on page 134 .
6	Remove the <i>SMB battery</i> . Battery includes protection circuits. Only replace with a specified spare part or with an ABB- approved equivalent.	Shown in figure Location of SMB battery on page 134 .

Refitting, battery

Use this procedure to refit the SMB battery.

	Action	Note
1	 DANGER Turn off all: <ul style="list-style-type: none"> • electric power supply • hydraulic pressure supply • air pressure supply to the robot, before entering the safeguarded space.	
2	 ELECTROSTATIC DISCHARGE (ESD) The unit is sensitive to ESD. Before handling the unit please read the safety information in the section The unit is sensitive to ESD on page 51	

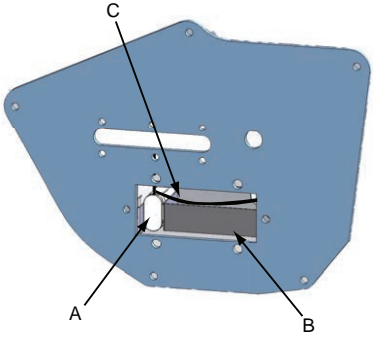
Continues on next page

	Action	Note
3	<p>Reconnect the <i>battery cable</i> and install the battery pack into the SMB/battery recess.</p> <p> Note</p> <p>RMU batteries are installed together with a battery holder to be properly secured inside the recess. See figure.</p>	<p>Art. no. is specified in Required equipment on page 135. Shown in figure Location of SMB battery on page 134.</p>  <p>xx1300001116</p> <p>A Battery pack RMU B Battery holder C Battery cable</p>
4	Secure the <i>SMB battery cover</i> with its attachment screws.	Shown in figure Location of SMB battery on page 134 .
5	Update the revolution counters.	Detailed in chapter Calibration - section Updating revolution counters on IRC5 robots on page 364 .
6	<p> DANGER</p> <p>Make sure all safety requirements are met when performing the first test run. See Test run after installation, maintenance, or repair on page 97.</p>	

3 Maintenance

3.5.1 Cleaning the IRB 460

3.5 Cleaning activities

3.5.1 Cleaning the IRB 460



DANGER

Turn off all:

- electric power supply
- hydraulic pressure supply
- air pressure supply

to the robot, before entering the safeguarded space.

General

To secure high uptime it is important that the IRB 460 is cleaned regularly. The frequency of cleaning depends on the environment in which the product works. Different cleaning methods are allowed depending on the type of protection of the IRB 460.



Note

Always verify the protection type of the robot before cleaning.

Oil spills

Oil spills from gearboxes

Use the following procedure if any oil spills are detected that can be suspected to originate from a gearbox.

- 1 Inspect that the oil level in the suspected gearbox is according to the recommendations, see [Inspection activities on page 104](#).
- 2 Write down the oil level.
- 3 Inspect the oil level again after, for example, 6 months.
- 4 If the oil level is decreased then replace the gearbox.

Special cleaning considerations

This section specifies some special considerations when cleaning the robot.

- Always use cleaning equipment as specified. Any other cleaning equipment may shorten the life of the robot.
- Always check that all protective covers are fitted to the robot before cleaning.
- Never point the water jet at connectors, joints, sealings, or gaskets.
- Do not use compressed air to clean the robot.
- Never use solvents that are not approved by ABB to clean the robot.
- Do not spray from a distance closer than 0.4 m.
- Do not remove any covers or other protective devices before cleaning the robot.

Continues on next page

Cleaning methods

The following table defines what cleaning methods are allowed depending on the protection type.

Protection type	Cleaning method			
	Vacuum cleaner	Wipe with cloth	Rinse with water	High pressure water or steam
Standard	Yes	Yes. With light cleaning detergent.	Yes. It is highly recommended that the water contains a rust-prevention solution and that the manipulator is dried afterwards.	No

Cleaning with water and steam

Instructions for rinsing with water

ABB robots with protection types *Standard*, *Foundry Plus*, *Wash*, or *Foundry Prime* can be cleaned by rinsing with water (water cleaner), provided that the robot is not equipped with the option of motor cooling fans.¹

The following list defines the prerequisites:

- Maximum water pressure at the nozzle: 700 kN/m² (7 bar)¹
- Fan jet nozzle should be used, min. 45° spread
- Minimum distance from nozzle to encapsulation: 0.4 meters
- Maximum flow: 20 liters/min¹

¹ Typical tap water pressure and flow

Cables

Movable cables need to be able to move freely:

- Remove waste material, such as sand, dust and chips, if it prevents cable movement.
- Clean the cables if they have a crusty surface, for example from dry release agents.

¹ See [Cleaning methods on page 139](#) for exceptions.

This page is intentionally left blank

4 Repair

4.1 Introduction

Structure of this chapter

This chapter describes repair activities for the IRB 460. Each procedure contains the information required to perform the activity, for example spare parts numbers, required special tools, and materials.



WARNING

Repair activities not described in this chapter must only be carried out by ABB.

Report replaced units



Note

When replacing a part on the IRB 460, report to your local ABB the serial number, the article number, and the revision of both the replaced unit and the replacement unit.

This is particularly important for safety equipment to maintain the safety integrity of the installation.

Safety information

Make sure to read through the chapter [Safety on page 19](#) before commencing any service work.



Note

If the IRB 460 is connected to power, always make sure that the IRB 460 is connected to protective earth and a residual current device (RCD) before starting any repair work.

For more information see:

- *Product manual - OmniCore V250XT Type A*
- *Product manual - OmniCore V250XT Type B*
- *Product manual - OmniCore V400XT*
- *Product manual - IRC5*
- *Product manual - IRC5 Compact*
- *Product manual - IRC5 Panel Mounted Controller*

4 Repair

4.2.1 Performing a leak-down test

4.2 General procedures

4.2.1 Performing a leak-down test

When to perform a leak-down test

After refitting any motor and gearbox, the integrity of all seals enclosing the gearbox oil must be tested. This is done in a leak-down test.

The gearbox must be drained of oil before performing the leak-down test.

Required equipment

Equipment, etc.	Article number	Note
Leak-down tester	-	
Leak detection spray	-	

Performing a leak-down test

	Action	Note
1	Finish the refitting procedure of the motor or gear in question, but do not refill the gearbox with oil before performing the leak-down test.	
2	Remove the upper oil plug on the gear and replace it with the leak-down tester. Regulators, which are included in the leak-down test, may be required.	
3	Use caution, apply compressed air and raise the pressure with the knob until the correct value is shown on the manometer.  CAUTION The pressure must under no circumstance be higher than 0.25 bar (20-25 kPa). Also during the time when the pressure is raised.	Correct value: 0.2-0.25 bar (20-25 kPa)
4	Disconnect the compressed air supply.	
5	Wait for approximately 8-10 minutes and make sure that no pressure loss occurs.	If the compressed air is significantly colder or warmer than the gearbox to be tested, a slight pressure increase or decrease may occur. This is quite normal.
6	If any pressure drop occurred, then localize the leak as described in step 7. If no pressure drop occurred, then remove the leak-down tester and refit the oil plug. The test is complete.	
7	Spray any suspected leak areas with the leak detection spray. Bubbles indicate a leak.	
8	When the leak has been localized, take the necessary measures to correct the leak.	

4.2.2 Mounting instructions for bearings

General

This section describes how to mount and grease different types of bearings on the robot.

Equipment

Equipment, etc.	Article number	Note
Grease	3HAC042536-001	Shell Gadus S2 Used to grease the bearings, if not specified otherwise.

Assembly of all bearings

Attend to the following instructions while mounting a bearing on the robot.

	Action	Note
1	To avoid contamination, let a new bearing remain in its wrapping until it is time for fitting.	
2	Ensure that the parts included in the bearing fitting are free from burrs, grinding waste, and other contamination. Cast components must be free of foundry sand.	
3	Bearing rings, inner rings, and roller elements must not be subjected to direct impact. The roller elements must not be exposed to any stresses during the assembly work.	

Assembly of tapered bearings

Follow the preceding instructions for the assembly of the bearings when mounting a tapered bearing on the robot.

In addition to those instructions, the following procedure must be carried out to enable the roller elements to adjust to the correct position against the race flange.

	Action	Note
1	Tension the bearing gradually until the recommended pre-tension is achieved.  Note The roller elements must be rotated a specified number of turns before pre-tensioning is carried out and also rotated during the pre-tensioning sequence.	
2	Make sure the bearing is properly aligned as this will directly affect the durability of the bearing.	

Greasing of bearings



Note

This instruction is not valid for solid oil bearings.

Continues on next page

4 Repair

4.2.2 Mounting instructions for bearings

Continued

The bearings must be greased after assembly according to the following instructions:

- The bearings must not be completely filled with grease. However, if space is available beside the bearing fitting, the bearing may be totally filled with grease when mounted, as excessive grease will be pressed out from the bearing when the robot is started.
- During operation, the bearing should be filled to 70-80% of the available volume.
- Ensure that grease is handled and stored properly to avoid contamination.

Grease the different types of bearings as following description:

- *Grooved ball bearings* must be filled with grease from both sides.
- *Tapered roller bearings* and axial needle bearings must be greased in the split condition.

4.2.3 Mounting instructions for sealings

General

This section describes how to mount different types of sealings.

Equipment

Consumable	Article number	Note
Grease	3HAC042536-001	Shell Gadus S2

Rotating sealings

The following procedures describe how to fit rotating sealings.



CAUTION

Please observe the following before commencing any assembly of sealings:

- Protect the sealing during transport and mounting, especially the main lip on radial sealings.
- Keep the sealing in its original wrappings or protect it well before actual mounting.
- The fitting of sealings and gears must be carried out on clean workbenches.
- Use a protective sleeve for the main lip during mounting, when sliding over threads, keyways or other sharp edges.
- Do not lubricate a static side of a sealing with grease, since this may result in movement of the sealing during operation.

The only exception for lubrication of static sides of a sealing, is to use P-80 rubber lubrication gel against certain aluminium surfaces. If usage of P-80 is relevant, it is stated in the repair procedures.

Radial sealings

A radial sealing consists of a flexible rubber lip bonded to a rigid metal case. Only one side of the sealing is static with a metal insert.

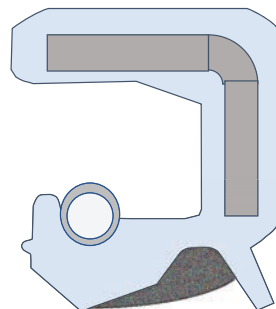



xx230000433

Continues on next page

4 Repair

4.2.3 Mounting instructions for sealings

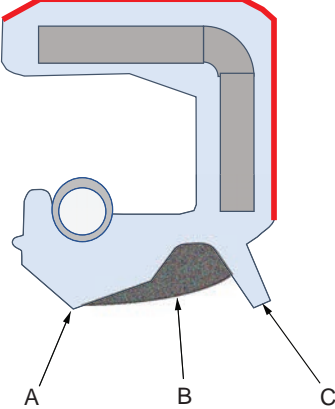
Continued

	Action	Note
1	Check the sealing to ensure that: <ul style="list-style-type: none"> • The sealing is of the correct type. • There is no damage on the main lip. 	
2	Inspect the shaft surface before mounting. If scratches or damage are found, the shaft must be replaced since it may result in future leakage. Do not try to grind or polish the shaft surface to get rid of the defect.	
3	Lubricate the sealing with grease just before fitting. (Not too early - there is a risk of dirt and foreign particles adhering to the sealing.) Fill 2/3 of the space between the dust lip and the main lip with grease. If the sealing is without dust lip, just lubricate the main lip with a thin layer of grease.	<p>Article number is specified in Equipment on page 145.</p>  <p>xx2000000071</p> <p>A Main lip B Grease C Dust lip</p> <p> Note</p> <p>Ensure that no grease is applied to the red marked surface.</p>

Continues on next page

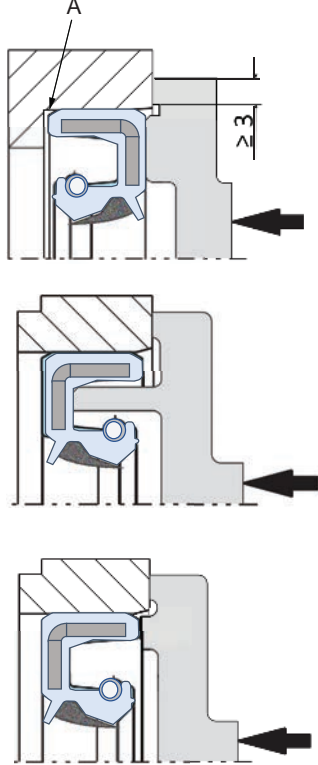
	Action	Note
4	Mount the sealing correctly with a mounting tool. Never hammer directly on the sealing as this may result in leakage.	 <p data-bbox="1093 1122 1203 1137">xx200000072</p> <p data-bbox="1129 1155 1214 1182">A Gap</p>

Flange sealings and static sealings

The following procedure describes how to fit flange sealings and static sealings.

	Action
1	Check the flange surfaces. They must be even and free from pores. It is easy to check flatness using a gauge on the fastened joint (without sealing compound). If the flange surfaces are defective, the parts may not be used because leakage could occur.
2	Clean the surfaces properly in accordance with the recommendations of ABB.
3	Distribute the sealing compound evenly over the surface.
4	Tighten the screws evenly when fastening the flange joint.

O-rings

The following procedure describes how to fit o-rings.

	Action	Note
1	Ensure that the correct o-ring size is used.	
2	Check the o-ring for surface defects, burrs, shape accuracy, or deformation.	Defective o-rings, including damaged or deformed o-rings, may not be used.

Continues on next page

4 Repair

4.2.3 Mounting instructions for sealings

Continued

	Action	Note
3	Check the o-ring grooves and mating surfaces. They should be free of pores, contamination and obvious scratches/damage.	
4	Lubricate the o-ring with grease.	
5	Tighten the screws evenly while assembling.	
6	Check that the o-ring is not squashed outside the o-ring groove.	

4.2.4 Cut the paint or surface on the robot before replacing parts

4.2.4 Cut the paint or surface on the robot before replacing parts

General

Follow the procedures in this section whenever breaking the paint of the robot during replacement of parts.

Required equipment

Equipment	Spare parts	Note
Cleaning agent		Ethanol
Knife		
Lint free cloth		
Touch up paint Standard/Foundry Plus	3HAC067974-001	Graphite White
Touch up paint Standard/Foundry Plus	3HAC037052-001	ABB Orange

Removing

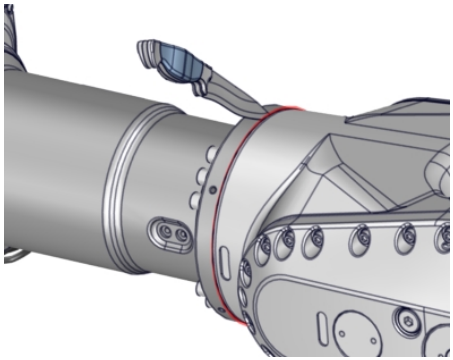
	Action	Description
1	Cut the paint with a knife in the joint between the part that will be removed and the structure, to avoid that the paint cracks.	 xx2300000950
2	Carefully grind the paint edge that is left on the structure to a smooth surface.	

4 Repair

4.2.5 The brake release buttons may be jammed after service work

4.2.5 The brake release buttons may be jammed after service work

Description

The brake release unit has push-buttons for the brake release of each axis motor. When service work is performed inside the SMB recess that includes removal and refitting of the brake release unit, the brake release buttons may be jammed after refitting.



DANGER

If the power is turned on while a brake release button is jammed in depressed position, the affected motor brake is released. This may cause serious personal injuries and damage to the robot.

Elimination

To eliminate the danger after service work has been performed inside the SMB recess, follow the procedure below.

	Action
1	Make sure the power is turned off.
2	Remove the push-button guard, if necessary.
3	Verify that the push-buttons of the brake release unit are working by pressing them down, one by one. Make sure none of the buttons are jammed in the tube.
4	If a button gets jammed in the depressed position, the alignment of the brake release unit must be adjusted so that the buttons can move freely in their tubes.

4.3 Complete robot

4.3.1 Replacing cable harness, lower end (axes 1-3)

Overview

The cable harness 1-6 is undivided.

How to replace the cable harness is described in two steps - lower end (axes 1-3) and upper end (axis 6). This procedure describes how to replace the lower end of the cable harness. How to replace the upper end can be found in section [Replacing the cable harness, upper end \(incl. axis 6\) on page 161](#).

Continues on next page

4 Repair

4.3.1 Replacing cable harness, lower end (axes 1-3)

Continued

Location of cable harness - lower end (axes 1-3)

The cable harness, lower end (axes 1-3) is located throughout the base, frame and lower arm as shown in the figure.

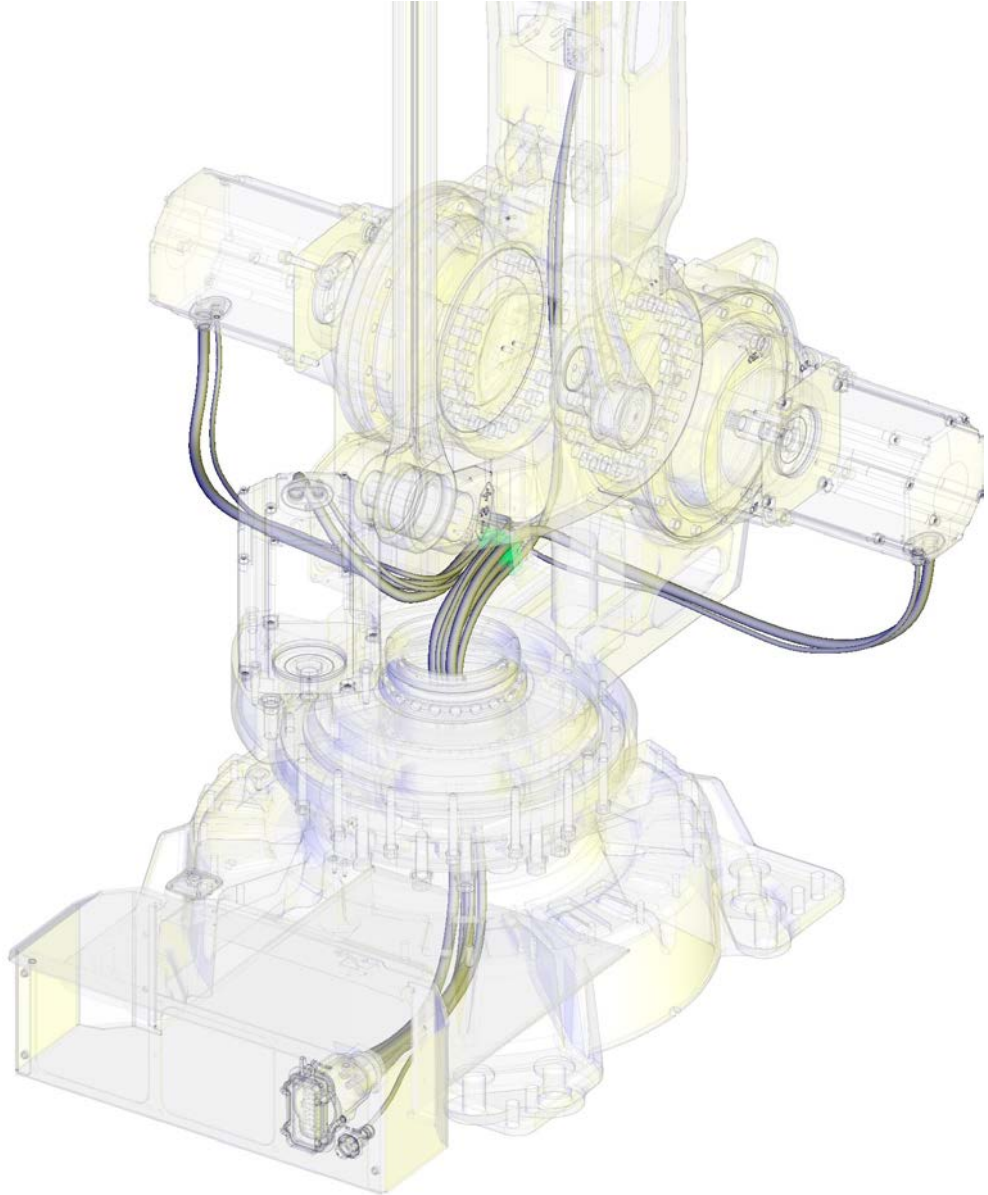

xx1100000153

Continues on next page

4.3.1 Replacing cable harness, lower end (axes 1-3)

Continued

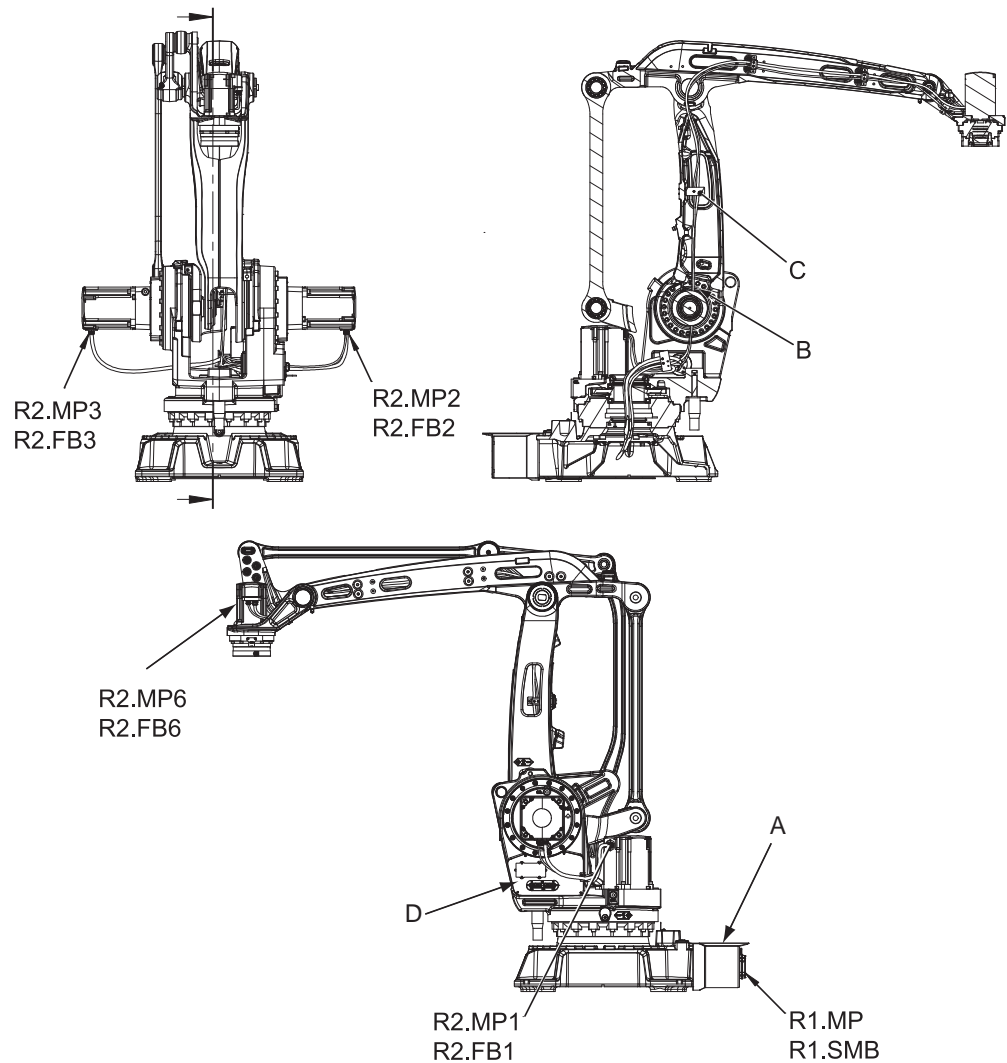

xx110000154

A	Rear cover plate
B	Cable guide, axis 2
C	Metal clamp
D	SMB cover
R2.MP6, R2.FB6	Connectors to the axis 6 motor

Required equipment

Equipment, etc.	Art.no.	Note
Cable harness 1-6	For spare part no. see: • Spare parts on page 403	
Gasket	3HAC3438-1	Motor, axes 1-3 Replace if damaged.
Standard toolkit	-	The content is defined in the section Standard tools on page 398 .

Continues on next page

4 Repair

4.3.1 Replacing cable harness, lower end (axes 1-3)

Continued

Equipment, etc.	Art.no.	Note
Other tools and procedures may be required. See references to these procedures in the step-by-step instructions below.	-	These procedures include references to the tools required.
Circuit diagram	-	See Circuit diagrams on page 405 .

Removing the cable harness - lower end (axes 1-3)

Use this procedure to remove the cable harness, lower end (axes 1-3).

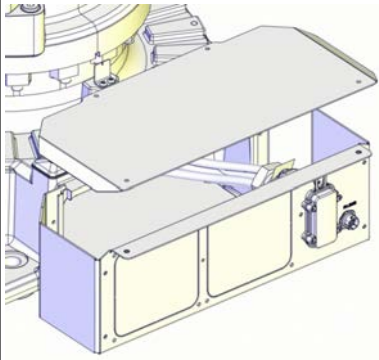
	Action	Note
1	Move the robot to the calibration position.	This is done in order to facilitate updating of the revolution counter.
2	 <p>DANGER</p> <p>Turn off all:</p> <ul style="list-style-type: none"> • electric power supply • hydraulic pressure supply • air pressure supply <p>to the robot, before entering the robot working area.</p>	
3	Remove the <i>rear cover plate</i> from the robot by removing its attachment screws.	 <p>xx110000155</p>

Continues on next page

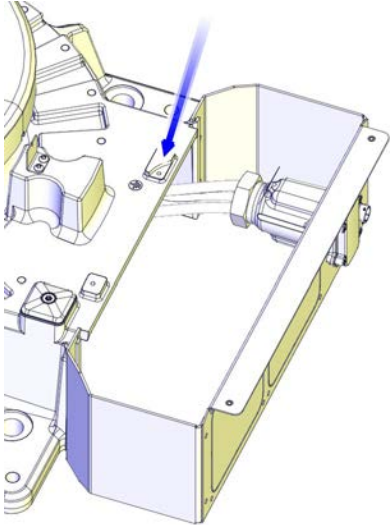
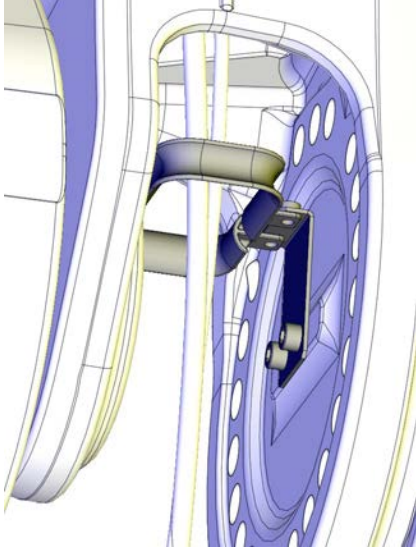
	Action	Note
4	Disconnect the <i>earth cable</i> .	 <p>xx110000156</p>
5	Disconnect the connectors <i>R1.MP</i> and <i>R1.SMB</i> .	See the figure Location of cable harness - lower end (axes 1-3) on page 152 .
6	Unscrew the screws of the <i>cable guide axis 2</i> inside the lower arm and loosen the cable guide.	 <p>xx110000157</p>
7	Unscrew the nuts (outside the lower arm) that secure the <i>metal clamp</i> that hold the cable harness inside the lower arm.	
8	Unscrew the screws of the motor covers for axes 1, 2 and 3 and lift away the covers. This is done in order to reach the motor connectors.	
9	Disconnect all connectors at motors for axes 1, 2 and 3.	See sections: <ul style="list-style-type: none"> • Replacing motor, axis 1 on page 301 • Replacing motors, axes 2 and 3 on page 309

Continues on next page

4 Repair

4.3.1 Replacing cable harness, lower end (axes 1-3)

Continued

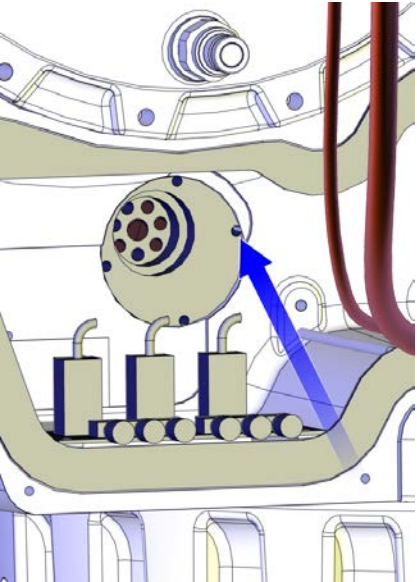
	Action	Note
10	Open the SMB cover carefully.	See the figure Location of cable harness - lower end (axes 1-3) on page 152 .
11	Disconnect connector R1.G on the <i>battery cable</i> between the battery and the SMB unit.  Note This causes a necessary updating of the revolution counter after refitting!	
12	Disconnect connectors R2.SMB, R1.SMB1-3, R1.SMB6 from the SMB unit.	
13	Disconnect X8, X9 and X10 from the brake release unit.	
14	Remove the SMB cover and put somewhere safe.	
15	Unscrew the screws for the <i>cable gland SMB</i> from inside the SMB recess and lift the cable gland out. Perform this removal with care, in order not to damage any of the components inside the SMB recess.	 <small>xx1000001330</small>

Continues on next page

4.3.1 Replacing cable harness, lower end (axes 1-3)

Continued

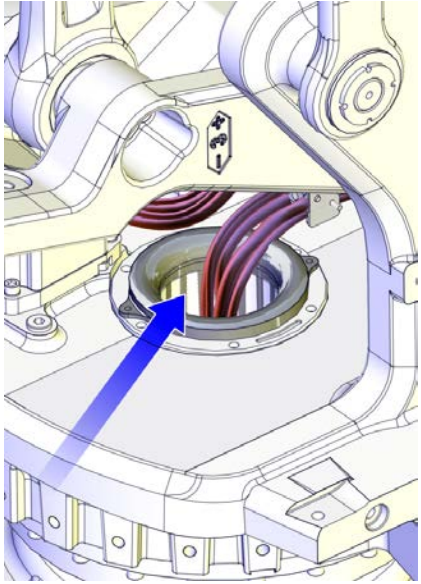
	Action	Note
16	Gently pull the cable harness out from the base through the <i>cable guide</i> , axis 1 and frame.	 <p>xx1000001331</p>
17	Continue removing the cable harness in the upper arm.	See section Replacing the cable harness, upper end (incl. axis 6) on page 161.

Refitting, cable harness - lower end (axes 1-3)

Use this procedure to refit the cable harness, lower end (axes 1-3).

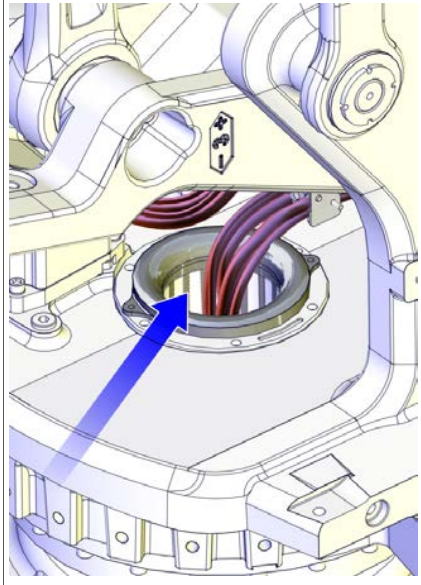
	Action	Note
1	<p>Push the cable harness and connectors down through the cable guide axis 1 in the center of the frame.</p> <p> CAUTION</p> <p>Make sure the cables are not twisted with each other or with customer harness (if any)!</p>	 <p>xx1000001331</p>

Continues on next page



4 Repair

4.3.1 Replacing cable harness, lower end (axes 1-3)

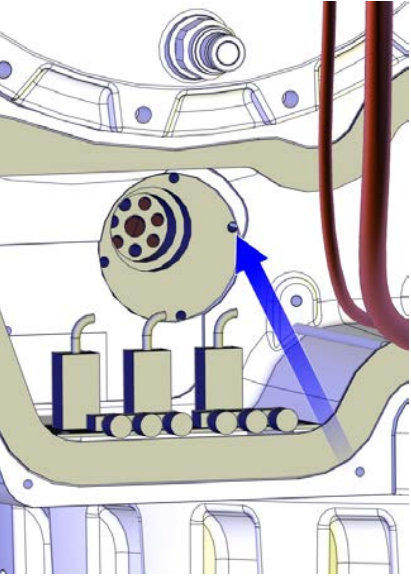
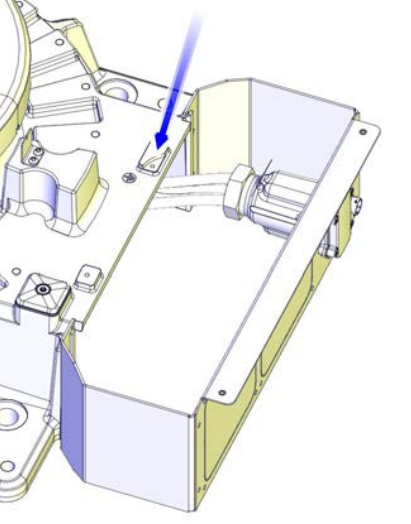
Continued

	Action	Note
2	<p>Pull out the cables and connectors of the SMB unit through the frame and refit the <i>cable gland</i> with its <i>attachment screws</i> from inside the SMB recess.</p> <p>Perform this refitting with care, in order not to damage any of the components inside the SMB recess.</p>	 <p>xx1000001330</p>
3	<p>Reconnect connectors <i>R1.MP</i> and <i>R1.SMB</i> at the robot base.</p>	<p>Tightening torque for <i>R1.SMB</i>: 10 Nm.</p> <p>Attachment points are shown in the figure <i>Location of cable harness - lower end (axes 1-3)</i> on page 152.</p>
4	<p>Reconnect the <i>earth cable</i>.</p>	 <p>xx1100000156</p>

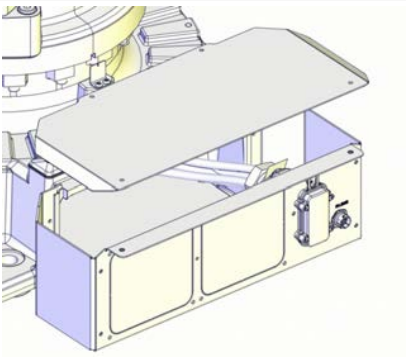
Continues on next page



	Action	Note
5	Refit the <i>rear cover plate</i> to the robot base with its attachment screws.	 <p>xx1100000155</p>
6	Reconnect all connectors at <i>motors axes 1, 2 and 3</i> and refit the motor covers.	See sections: <ul style="list-style-type: none"> • Replacing motor, axis 1 on page 301 • Replacing motors, axes 2 and 3 on page 309
7	Reconnect connectors R2.SMB, R1.SMB1-3, R1.SMB6 of the SMB unit. Reconnect X8, X9 and X10 to the brake release unit. Reconnect R1.G.	
8	Secure the <i>SMB cover</i> with its attachment screws. If cabling is used for 7th axis (option), refit the connector R2.FB7 to the SMB cover and tighten with 6 Nm.	
9	 WARNING Before continuing any service work, please observe the safety information in section The brake release buttons may be jammed after service work on page 150 .	
10	Push the cable harness up through the lower arm.	
11	Fasten the metal clamp that hold the cable harness in the lower arm with the nuts.	

Continues on next page

4 Repair

4.3.1 Replacing cable harness, lower end (axes 1-3)

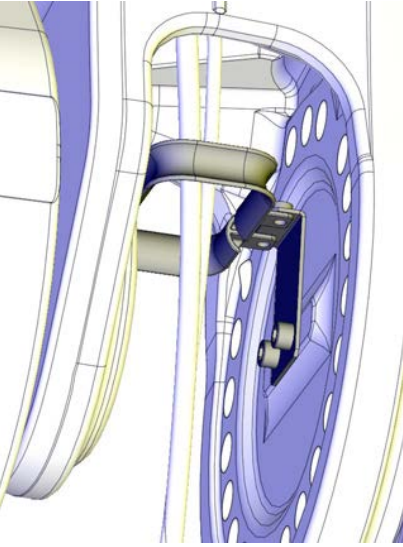
Continued

	Action	Note
12	Refit the <i>cable guide, axis 2</i> .	 xx1100000157
13	Continue refitting the cable harness in the upper arm.	See section Replacing the cable harness, upper end (incl. axis 6) on page 161 .
14	Make an overall inspection of the installed cable harness.	See Inspecting, cable harness on page 111 .
15	Update the revolution counter!	See section Updating revolution counters on IRC5 robots on page 364 .
16	 DANGER Make sure all safety requirements are met when performing the first test run. See Test run after installation, maintenance, or repair on page 97 .	

4.3.2 Replacing the cable harness, upper end (incl. axis 6)

Overview

Replacement of the cable harness is detailed in two steps - lower end (axes 1-3) and upper end. The procedure below details replacement of the cable harness in the upper end (incl. axis 6). The procedure for replacing the lower end (axis 1-3) is detailed in section [Replacing cable harness, lower end \(axes 1-3\) on page 151](#).

Location of cable harness, upper end

The upper end of the cable harness is located as shown in the figure.

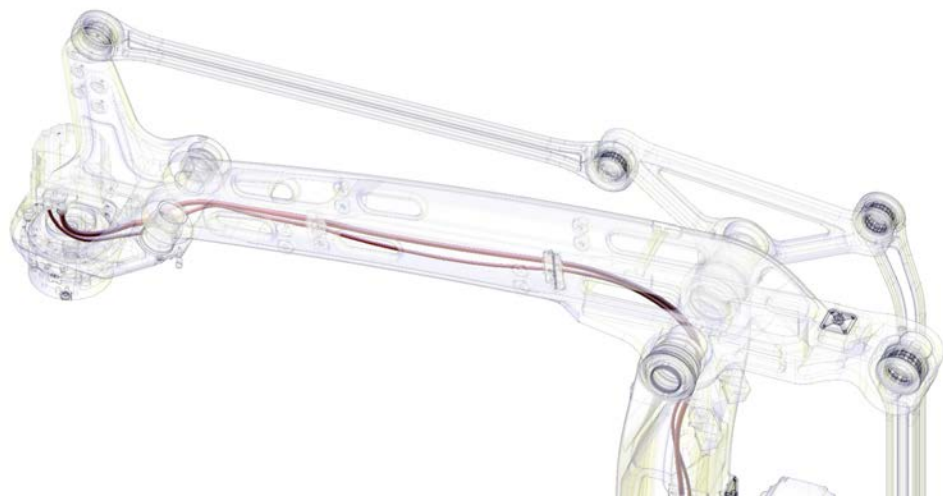

xx110000158

Continues on next page

4 Repair

4.3.2 Replacing the cable harness, upper end (incl. axis 6)

Continued

The motor axis 6 is located as shown in the figure below.

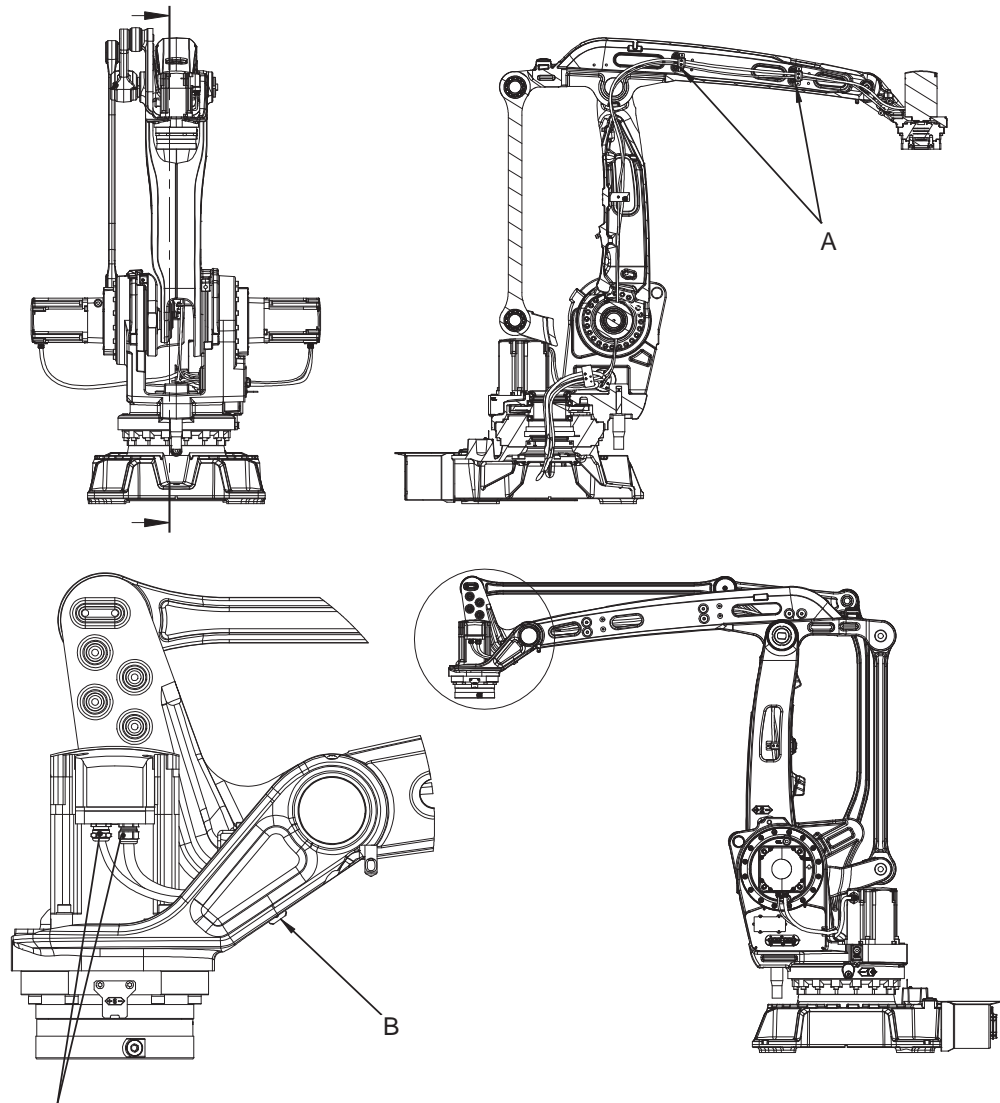

R2.MP6
R2.FB6

xx1100000159

- A: Metal clamps with nuts (upper arm)
- B: Metal clamp (tilthouse)
- R2.MP6, R2.FB6 = Connectors to the axis 6 motor

Required equipment

Equipment, etc	Art.no.	Note
Cable harness, 1-6	For spare part no. see: <ul style="list-style-type: none">• Spare parts on page 403	
Gasket	-	Motor, axis 6
Standard toolkit	-	Content is defined in section Standard tools on page 398 .

Continues on next page

4.3.2 Replacing the cable harness, upper end (incl. axis 6)

Continued

Equipment, etc	Art.no.	Note
Other tools and procedures may be required. See references to these procedures in the step-by-step instructions below.		These procedures include references to the tools required.
Circuit diagram	See chapter <i>Circuit diagrams on page 405</i> .	

Removing cable harness, upper end (incl. axis 6)

Use this procedure to remove the cable harness, upper arm (incl. axis 6).

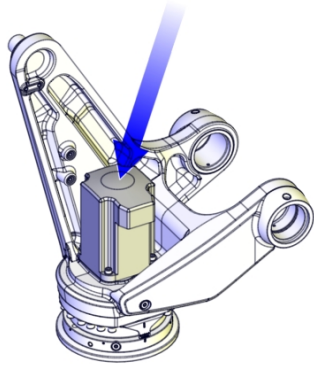
	Action	Note
1	Move the robot to the calibration position.	This is done in order to facilitate updating of the revolution counter.
2	 <p>DANGER</p> <p>Turn off all:</p> <ul style="list-style-type: none"> • electric power supply • hydraulic pressure supply • air pressure supply <p>to the robot, before entering the robot working area.</p>	
3	If the complete cable harness is being replaced, start removal by removing the <i>cable harness, lower end</i> .	Detailed in section <i>Replacing cable harness, lower end (axes 1-3) on page 151</i> .
4	Remove the axis 6 motor cover by removing its attachment screws, in order to reach the connectors.	 <p>xx1000001106</p>

Continues on next page

4 Repair

4.3.2 Replacing the cable harness, upper end (incl. axis 6)

Continued

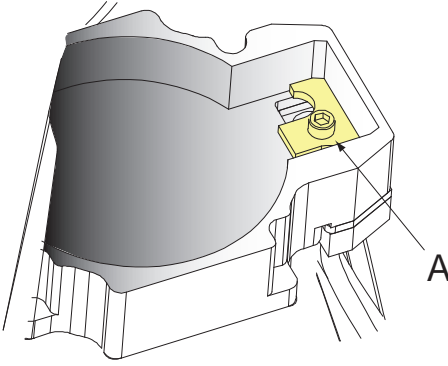
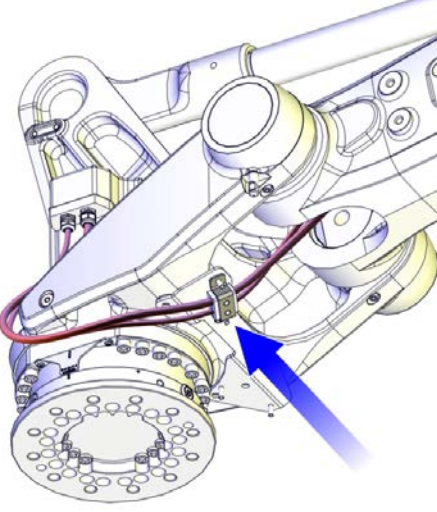
Action	Note
<p>Remove the <i>cable gland cover</i> at the cable exit by unscrewing its <i>attachment screw</i> on the inside.</p> <p> Note</p> <p>Make sure the gasket is not damaged!</p>	 <p>xx0600002694</p> <ul style="list-style-type: none">• A: Screw securing the cable gland
5 Disconnect connectors at axis 6 motor.	
6 Remove the metal clamp that holds the cable at the tilt house, by removing its nuts.	 <p>xx1000001336</p>
7 Carefully pull the cable harness out of motor axis 6.	

Continues on next page

4.3.2 Replacing the cable harness, upper end (incl. axis 6)

Continued

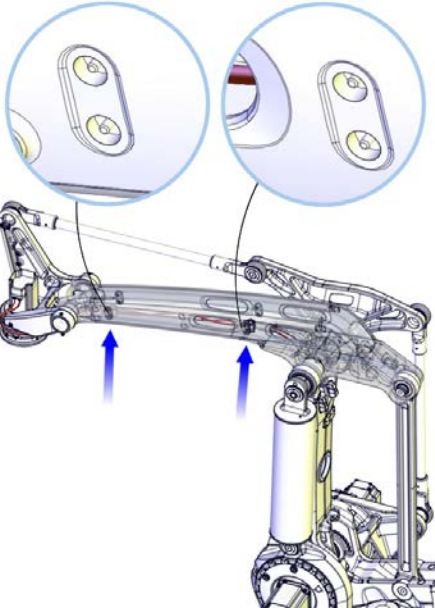
	Action	Note
8	Remove the nuts (on the outside of the upper arm) that secure the cable harness metal clamps inside the upper arm (2 + 2 pcs).	 <p>xx1000001338</p>
9	Carefully pull out the cable harness from the upper and lower arm.	

Refitting cable harness, upper end

Use this procedure to refit the cable harness, upper end.



	Action	Note
1	Start by fitting the cable harness, lower end if it has been removed.	Detailed in section Replacing cable harness, lower end (axes 1-3) on page 151
2	Push the cable harness through the upper arm tube.	

Continues on next page



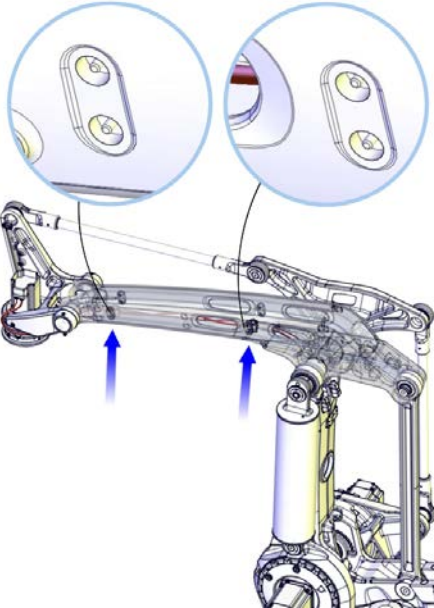
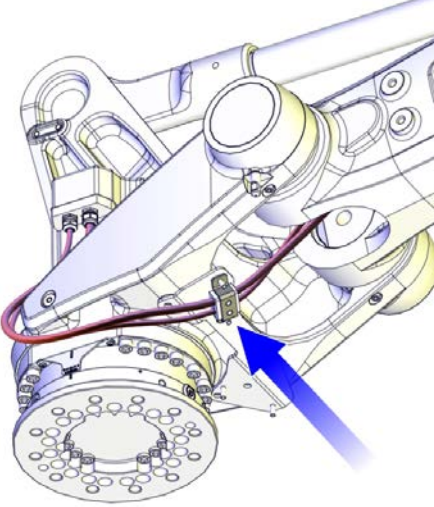

4 Repair

4.3.2 Replacing the cable harness, upper end (incl. axis 6)

Continued

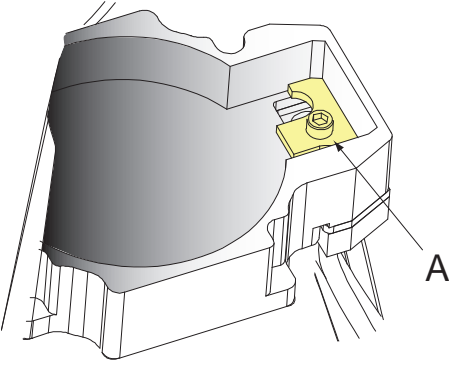
	Action	Note
3	Refit the cable harness inside the upper arm by refitting the cable clamps with the nuts (2 + 2 pcs) from the outside of the upper arm.	 <p>xx1000001338</p>
4	Refit the <i>metal clamp</i> at the tilthouse with its nuts.	 <p>xx1000001336</p>
5	Push the axis 6 motor cables carefully through the cable gland.  Note Do not twist the cables!	
6	Reconnect all connectors in motor axis 6.	
7	Check the <i>gasket</i> . If damaged, replace it.	

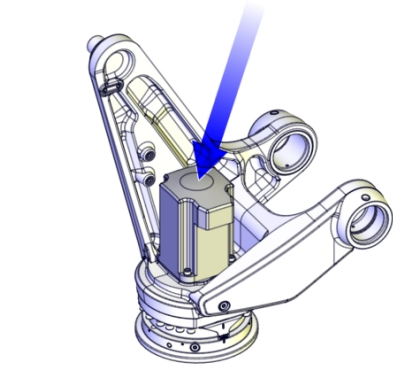
Continues on next page

	Action	Note
8	Refit the cable gland with its <i>attachment screw</i> .	 <p>xx0600002694</p> <ul style="list-style-type: none"> A: Screw holding the cable gland <p>Make sure the gasket is not damaged! Replace if damaged.</p>
9	Refit the <i>cover</i> , motor axis 6 with its <i>attachment screws</i> and <i>washers</i> . Make sure the cabling is placed correctly when refitting the cover and does not get jammed.  Note Make sure the cover is tightly sealed!	 <p>xx1000001106</p>
10	Make an overall inspection of the installed cable harness.	See Inspecting, cable harness on page 111 .
11	Update the revolution counter!	Detailed in section Updating revolution counters on IRC5 robots on page 364 .
12	 DANGER Make sure all safety requirements are met when performing the first test run. See Test run after installation, maintenance, or repair on page 97 .	

4 Repair

4.3.3 Replacing customer cable harness (optional)

4.3.3 Replacing customer cable harness (optional)

Overview

Three types of customer cable harness are available for IRB 460:

- Cable harness with Parallel/DeviceNet/Profibus and air hoses
- Cable harness with Parallel and air hoses
- Cable harness with Parallel/Ethernet and air hoses

Location of customer cable harness

The customer cable harness is located as shown in the figure.



xx2100002528

Required equipment

Equipment, etc.	Art.no.	Note
Cable harness, Customer CP/CS/CBUS	3HAC040447-001	
Cable harness, Customer CP/CS	3HAC040449-001	
Cable harness, Customer Ethernet/CP/CS	3HAC078114-001	
Standard toolkit	-	The content is defined in the section Standard tools on page 398 .

Continues on next page

Equipment, etc.	Art.no.	Note
Other tools and procedures may be required. See references to these procedures in the step-by-step instructions below.	-	These procedures include references to the tools required.
Circuit diagram	-	See Circuit diagrams on page 405 .

Removing the customer cable harness

Use this procedure to remove the customer cable harness.

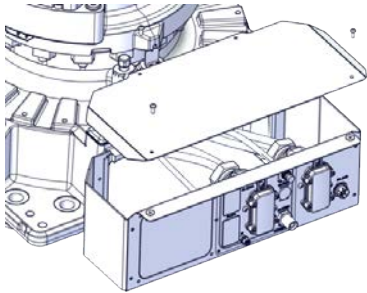
	Action	Note
1	Move the robot to the calibration position.	This is done in order to facilitate updating of the revolution counter.
2	 DANGER Turn off all: <ul style="list-style-type: none"> • electric power supply • hydraulic pressure supply • air pressure supply to the robot, before entering the robot working area.	
3	Remove the <i>rear cover plate</i> from the robot by removing its attachment screws.	 xx2100002529

Continues on next page

4 Repair

4.3.3 Replacing customer cable harness (optional)

Continued

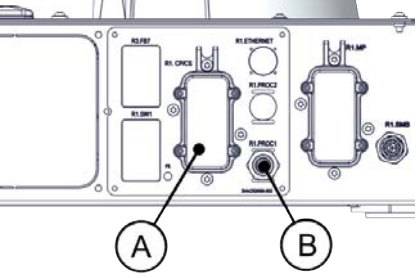
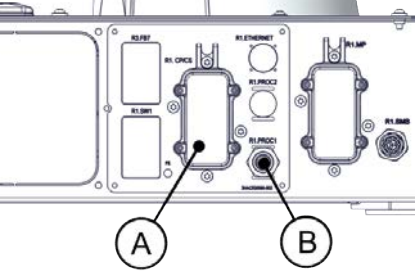
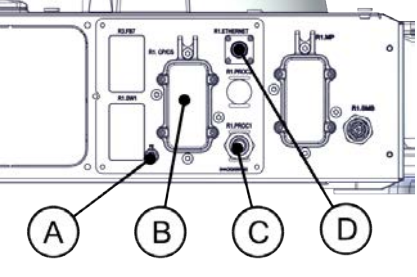
	Action	Note
4	<p>Disconnect the connectors on the base.</p> <p>For cable harness with Parallel + DeviceNet/Profibus + air hoses</p> <ul style="list-style-type: none"> • R1.CP/CS (A) • R1.PROC1 (B) 	 <p>xx2100002530</p>
	<p>For cable harness with Parallel + air hoses</p> <ul style="list-style-type: none"> • R1.CP/CS (A) • R1.PROC1 (B) 	 <p>xx2100002530</p>
	<p>For cable harness with Parallel + Ethernet + air hoses</p> <ul style="list-style-type: none"> • FE (A) • R1.CP/CS (B) • R1.PROC1 (C) • R1.ETHERNET (D) 	 <p>xx2100002531</p>

Continues on next page

4.3.3 Replacing customer cable harness (optional)

Continued

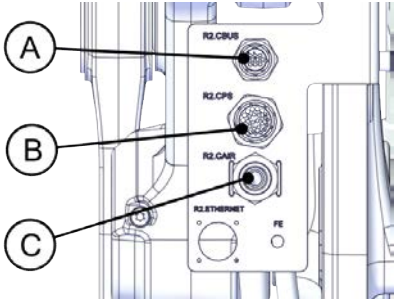
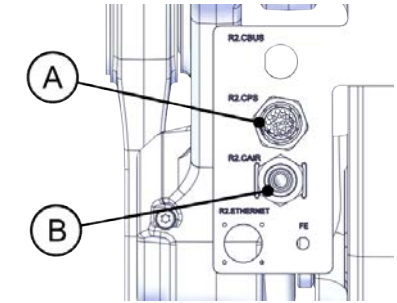
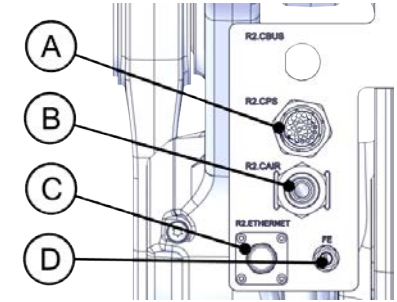
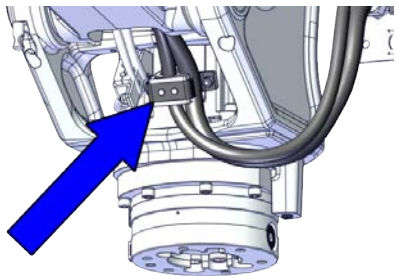
	Action	Note
5	<p>Disconnect the connectors on the tilthouse unit.</p> <p>For cable harness with Parallel + DeviceNet/Profibus + air hoses</p> <ul style="list-style-type: none"> • R2.CBUS (A) • R2.CPS (B) • R2.CAIR (C) <p>For cable harness with Parallel + air hoses</p> <ul style="list-style-type: none"> • R2.CPS (A) • R2.CAIR (B) <p>For cable harness with Parallel + Ethernet + air hoses</p> <ul style="list-style-type: none"> • R2.CPS (A) • R2.CAIR (B) • R2.ETHERNET (C) • FE (D) 	 <p>xx2100002532</p>  <p>xx2100002533</p>  <p>xx2100002534</p>
6	<p>Remove the <i>metal clamp</i> that holds the cable at the tilt house, by removing its nuts.</p>	 <p>xx2100002535</p>

Continues on next page

4 Repair

4.3.3 Replacing customer cable harness (optional)

Continued

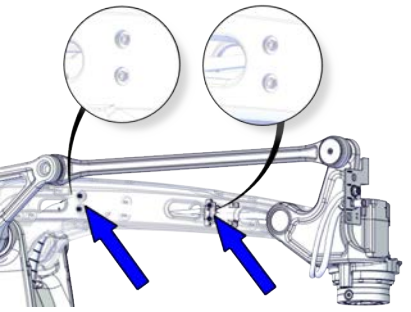
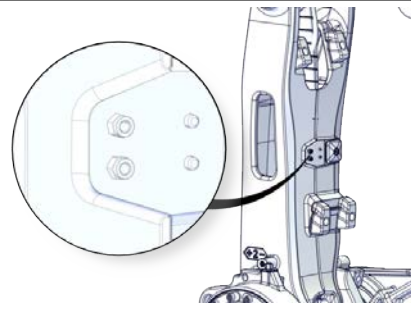
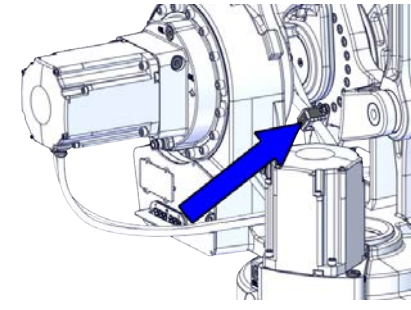
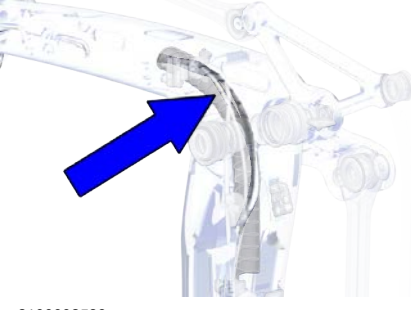
	Action	Note
7	Remove the nuts (on the outside of the upper arm) that secure the <i>metal clamps</i> that hold the cable harness inside the upper arm (2 pcs + 2 pcs).	 <p data-bbox="991 618 1098 640">xx2100002536</p>
8	Remove the nuts (on the outside of the lower arm) that secure the <i>metal clamp</i> that holds the cable harness inside the lower arm (2 pcs).	 <p data-bbox="991 976 1098 999">xx2100002537</p>
9	Remove the nuts that secure the <i>metal clamp</i> that holds the cable harness in the frame (2 pcs).	 <p data-bbox="991 1335 1098 1357">xx2100002538</p>
10	Remove the cable protection tube.	 <p data-bbox="991 1693 1098 1715">xx2100002539</p>
11	Wrap the connectors with masking tape for protection.	
12	Gently pull the cable harness out from the upper arm and lower arm.	
13	Gently pull the cable harness out from the base through the <i>cable guide</i> , axis 1 and frame.	

Continues on next page

Refitting the customer cable harness

Use this procedure to refit the customer cable harness.

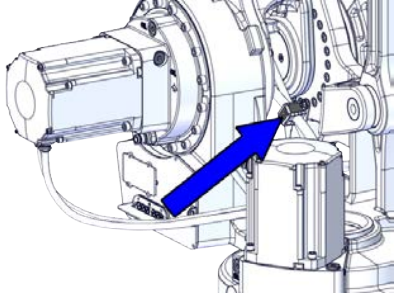
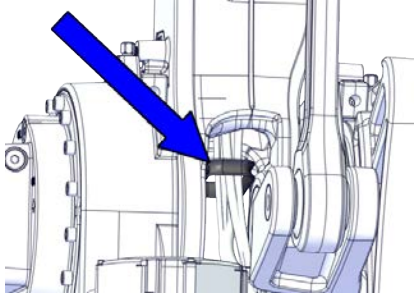
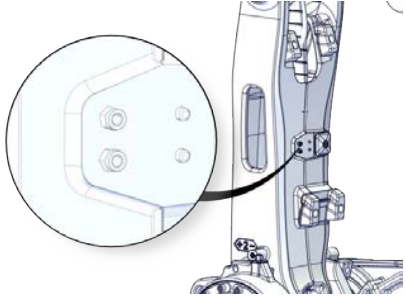
	Action	Note
1	Wrap the connectors with masking tape for protection.	
2	<p>Push the cable harness down through the cable guide axis 1 in the center of the frame.</p> <p> CAUTION</p> <p>Make sure the cables are not twisted with each other or with other motor harness!</p>	
3	Fasten the <i>metal clamp</i> that holds the cable harness in the frame with the nuts (2 pcs).	 <p>xx2100002538</p>
4	Guide the cable harness up through the <i>cable guide, axis 2</i> and into the lower arm, and then push the cable harness up through the upper arm.	 <p>xx2100002540</p>
5	Fasten the <i>metal clamp</i> that holds the cable harness in the lower arm with the nuts (2 pcs).	 <p>xx2100002537</p>

Continues on next page

4 Repair

4.3.3 Replacing customer cable harness (optional)

Continued

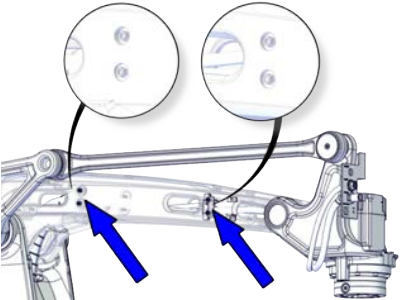
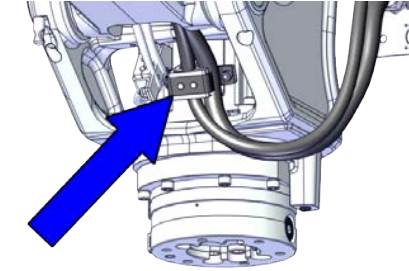
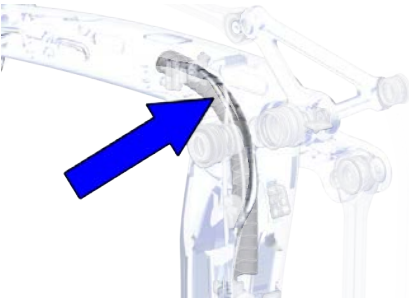
	Action	Note
6	Fasten the <i>metal clamps</i> that hold the cable harness in the upper arm with the nuts (2 pcs + 2 pcs).	 xx2100002536
7	Fasten the <i>metal clamp</i> that holds the cable harness in the tilthouse unit with the nuts (2 pcs).	 xx2100002535
8	Fix the cable protection tube around the cables in the lower arm and upper arm.	 xx2100002539

Continues on next page

4.3.3 Replacing customer cable harness (optional)

Continued

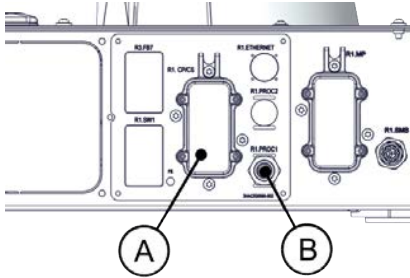
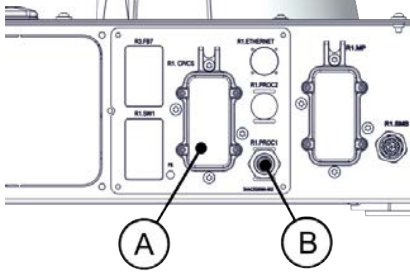
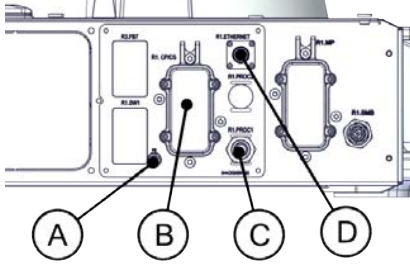

Action	Note
<p>9 Reconnect the connectors on the base.</p> <p>For cable harness with Parallel + DeviceNet/Profibus + air hoses</p> <ul style="list-style-type: none"> • R1.CP/CS (A) • R1.PROC1 (B) 	 <p>xx2100002530</p>
<p>For cable harness with Parallel + air hoses</p> <ul style="list-style-type: none"> • R1.CP/CS (A) • R1.PROC1 (B) 	 <p>xx2100002530</p>
<p>For cable harness with Parallel + Ethernet + air hoses</p> <ul style="list-style-type: none"> • FE (A) • R1.CP/CS (B) • R1.PROC1 (C) • R1.ETHERNET (D) 	 <p>xx2100002531</p>

Continues on next page

4 Repair

4.3.3 Replacing customer cable harness (optional)

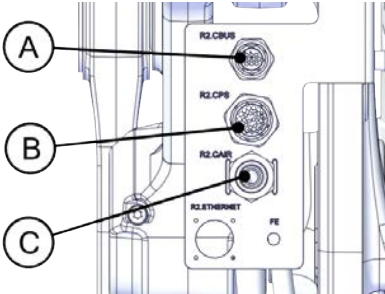
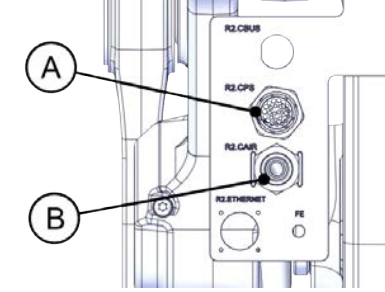
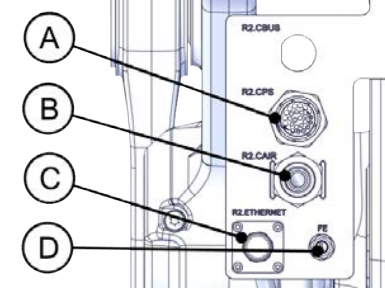
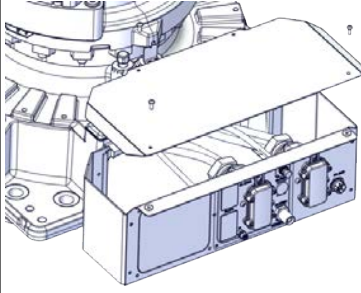
Continued

	Action	Note
10	<p>Reconnect the connectors on the tilthouse unit.</p> <p>For cable harness with Parallel + DeviceNet/Profibus + air hoses</p> <ul style="list-style-type: none"> • R2.CBUS (A) • R2.CPS (B) • R2.CAIR (C) 	 <p>xx2100002532</p>
	<p>For cable harness with Parallel + air hoses</p> <ul style="list-style-type: none"> • R2.CPS (A) • R2.CAIR (B) 	 <p>xx2100002533</p>
	<p>For cable harness with Parallel + Ethernet + air hoses</p> <ul style="list-style-type: none"> • R2.CPS (A) • R2.CAIR (B) • R2.ETHERNET (C) • FE (D) 	 <p>xx2100002534</p>
11	<p>Refit the <i>rear cover plate</i> to the robot base with its attachment screws.</p>	<p>Tightening torque: 6 Nm</p>  <p>xx2100002529</p>
12	<p> WARNING</p> <p>Before continuing any service work, please observe the safety information in section The brake release buttons may be jammed after service work on page 150.</p>	

Continues on next page

	Action	Note
13	 DANGER Make sure all safety requirements are met when performing the first test run. See Test run after installation, maintenance, or repair on page 97 .	

4 Repair

4.3.4 Replacing the SMB unit

4.3.4 Replacing the SMB unit

Location of SMB unit

The SMB unit (SMB = serial measurement board) is located on the left hand side of the frame as shown in the figure.

SMB board DSQC 633A (with 2-pole contact)

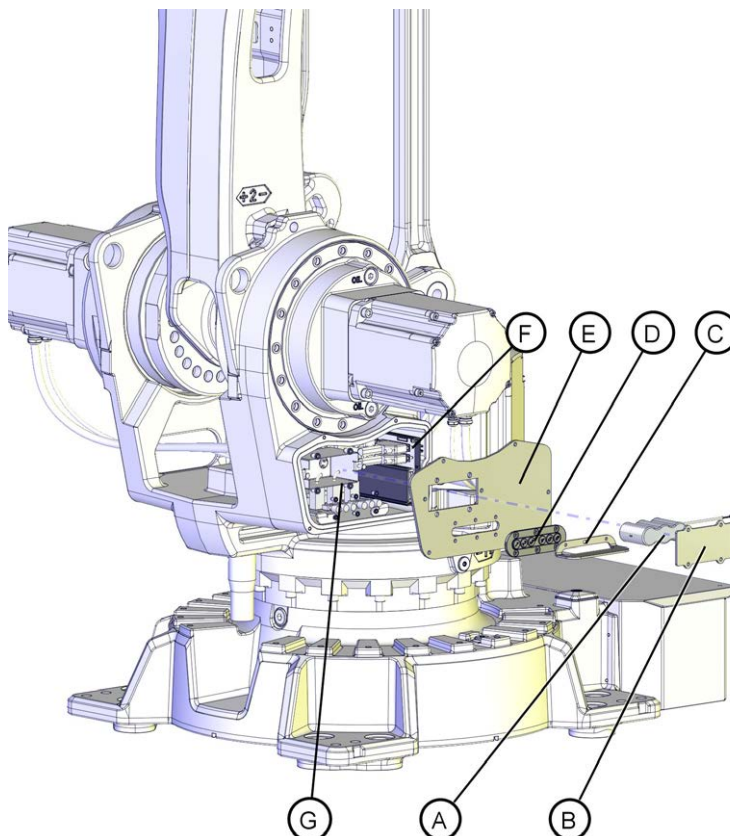

xx1100000105

A	Battery pack (2-pole battery contact)
B	Cover
C	BU button guard plate
D	Push button guard
E	Cover SMB
F	SMB unit
G	Brake release unit

Continues on next page

SMB board RMU 101 (with 3-pole contact)

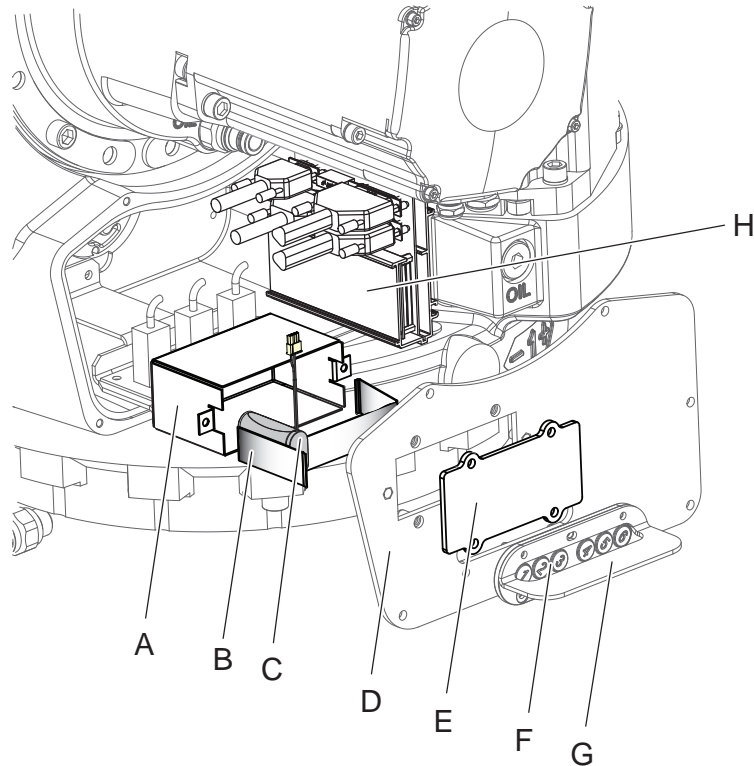

xx1300001115

A	Battery box
B	Battery holder
C	Battery pack, RMU lithium (3-pole battery contact)
D	SMB cover
E	Battery cover
F	BU button guard plate
G	Push button guard
H	Serial measurement board, RMU 101

Required equipment



Note

There are different variants of SMB units and batteries. The variant with the 3-pole battery contact has longer lifetime for the battery.

It is important that the SMB unit uses the correct battery. Make sure to order the correct spare parts. Do not replace the battery contact!

Equipment, etc.	Article number	Note
SMB unit	For spare part number, see: Spare parts on page 403.	

Continues on next page

4 Repair



4.3.4 Replacing the SMB unit

Continued

Equipment, etc.	Article number	Note
Battery pack	For spare part number, see: Spare parts on page 403 .	
Standard toolkit	-	Content is defined in section Standard tools on page 398 .
Circuit diagram	-	See chapter Circuit diagrams on page 405 .

Removing, SMB unit

Use this procedure to remove the SMB unit.

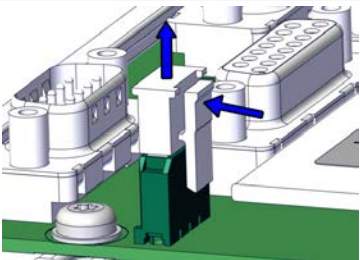

	Action	Note
1	Move the robot to the calibration position.	
2	 DANGER Turn off all: <ul style="list-style-type: none">• electric power supply• hydraulic pressure supply• air pressure supply to the robot, before entering the robot working area.	
3	 ELECTROSTATIC DISCHARGE (ESD) The unit is sensitive to ESD. Before handling the unit read the safety information in section The unit is sensitive to ESD on page 51 .	
4	Remove the SMB cover by unscrewing its attachment screws.  CAUTION Clean cover from metal residues before opening. Metal residues can cause shortage on the boards which can result in hazardous failures.	Shown in the figure Location of SMB unit on page 178 .
5	Use caution and remove the connectors X8, X9 and X10 from the brake release board, if need of more space.	
6	Remove the nuts and washers from the guide pins that secure the board.	Shown in the figure Location of SMB unit on page 178 .
7	Use caution and disconnect the connectors from the SMB unit when pulling the board out.	Connectors R1.SMB1-3, R1.SMB4-6 and R2.SMB

Continues on next page

	Action	Note
8	Disconnect the battery cable by pressing down the upper lip of the R2.G connector to release the lock while pulling the connector upwards.	 <p>xx170000993</p>

Refitting, SMB unit

Use this procedure to refit the SMB unit.

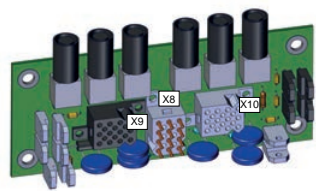
	Action	Note
1	 <p>DANGER</p> Turn off all: <ul style="list-style-type: none"> • electric power supply • hydraulic pressure supply • air pressure supply to the robot, before entering the robot working area.	
2	 <p>ELECTROSTATIC DISCHARGE (ESD)</p> The unit is sensitive to ESD. Before handling the unit read the safety information in section The unit is sensitive to ESD on page 51 .	
3	Connect the <i>battery cable</i> to the SMB unit. Make sure the lock on the battery cable connector R2.G snaps into place during refitting.	Shown in the figure Location of SMB unit on page 178 .
4	Connect all connectors to the SMB board: R1.SMB1-3, R1.SMB6 and R2.SMB	Art. no. is specified in Required equipment on page 179 . Shown in the figure Location of SMB unit on page 178 .
5	Fit the <i>SMB unit</i> onto the <i>guide pins</i> .	
6	Secure the SMB unit to the pins with the nuts and washers.	
7	If disconnected, reconnect the connectors X8, X9 and X10 to the brake release board. Be careful not to damage the sockets or pins. Make sure the connector and its locking arms are snapped down properly.	 <p>xx170000978</p>

Continues on next page

4 Repair

4.3.4 Replacing the SMB unit

Continued

	Action	Note
8	Secure the <i>SMB cover</i> with its attachment screws. If cabling is used for 7th axis (option), refit the 7th axis connector to the SMB cover and tighten with 6 Nm.	Shown in the figure Location of SMB unit on page 178 .
9	Update the revolution counters.	See Updating revolution counters on IRC5 robots on page 364 .
10	 DANGER Make sure all safety requirements are met when performing the first test run. See Test run after installation, maintenance, or repair on page 97 .	

4.3.5 Replacing the brake release board

Location of brake release board

The brake release unit is located together with the SMB unit on the left hand side of the frame, right next to the gearbox, axis 2, as shown in figure below.

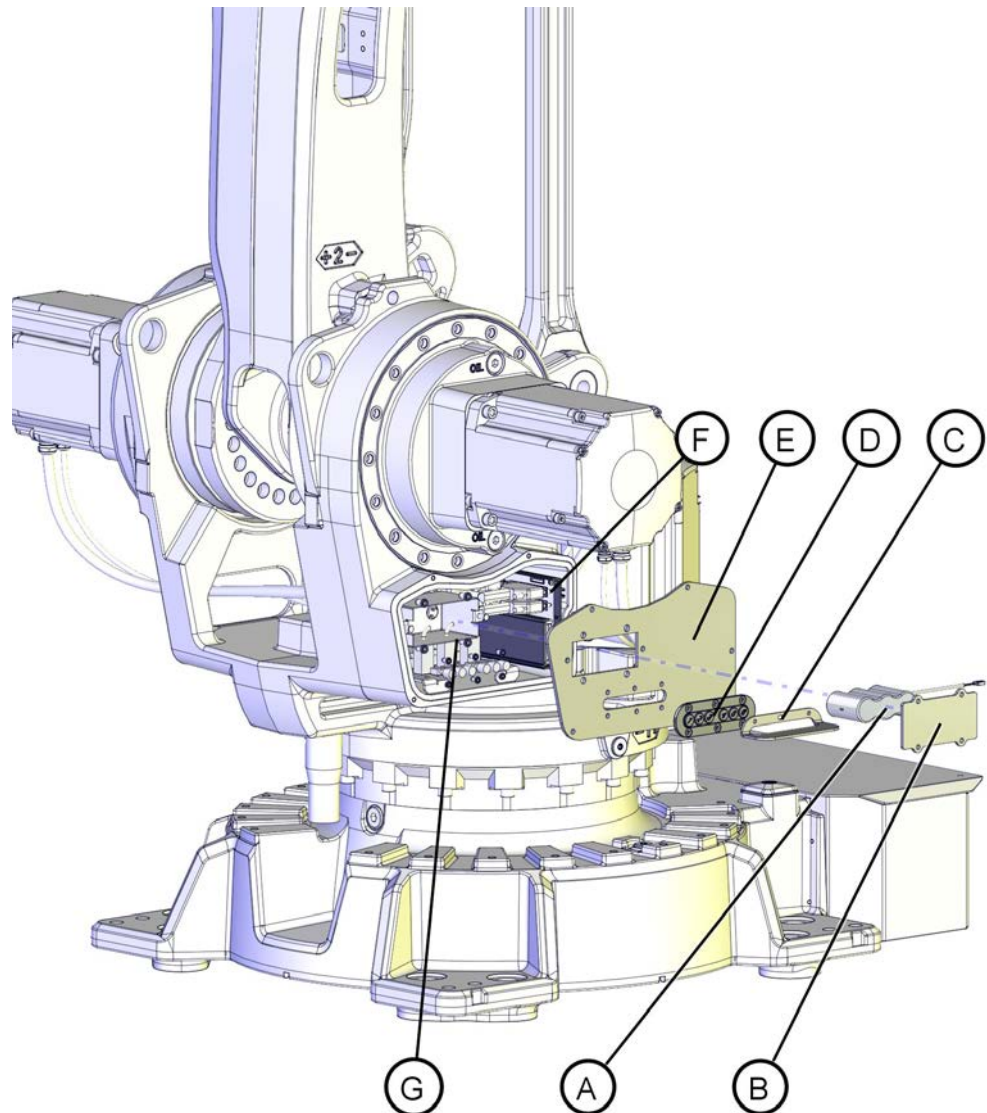

xx110000105

A	Battery pack (2-pole battery contact)
B	Cover
C	BU button guard plate
D	Push button guard
E	Cover SMB
F	SMB unit
G	Brake release unit

Continues on next page

4 Repair

4.3.5 Replacing the brake release board



Continued

Required equipment

Equipment, etc.	Article number	Note
Brake release board	3HAC065020-001	DSQC1050
Standard toolkit	-	Content is defined in section Standard tools on page 398 .
Other tools and procedures may be required. See references to these procedures in the step-by-step instructions below.		These procedures include references to the tools required.

Removing, brake release board

Use this procedure to remove the brake release board.

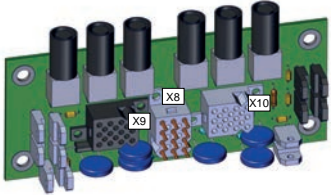

	Action	Note
1	 DANGER Turn off all: <ul style="list-style-type: none">• electric power supply to the robot• hydraulic pressure supply to the robot• air pressure supply to the robot Before entering the robot working area.	
2	 ELECTROSTATIC DISCHARGE (ESD) The unit is sensitive to ESD. Before handling the unit read the safety information in section The unit is sensitive to ESD on page 51 .	
3	Remove the push button guard from the SMB cover.	Shown in the figure Location of brake release board on page 183 . The guard must be removed to ensure a correct refitting of the brake release board.
4	Open the SMB cover by unscrewing the attachment screws. Let the battery stay connected, to avoid the need of synchronization of the robot!  CAUTION Clean cover from metal residues before opening. Metal residues can cause shortage on the boards which can result in hazardous failures.	Shown in the figure Location of brake release board on page 183 .
5	Take a picture or make notes of how the robot cabling is positioned in regard to the brake release board.	
6	Remove the complete brake release board (including brake release board and bracket) from the SMB recess, by removing its two attachment screws.	

Continues on next page

	Action	Note
7	Disconnect the connectors X8, X9 and X10 from the brake release board.	 <p>xx1700000978</p> <p>Location of the brake release unit is shown in the figure Location of brake release board on page 183.</p>
8	Remove the brake release board from the bracket by removing the four attachment screws.	

Refitting, brake release board

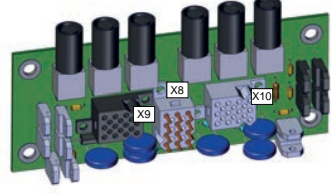
Use this procedure to refit the brake release board.



	Action	Note
1	 <p>ELECTROSTATIC DISCHARGE (ESD)</p> <p>The unit is sensitive to ESD. Before handling the unit read the safety information in section The unit is sensitive to ESD on page 51.</p>	
2	Connect the connectors X8, X9 and X10 to the brake release board. Be careful not to damage the sockets or pins. Make sure the connector and its locking arms are snapped down properly.	 <p>xx1700000978</p>
3	Fasten the <i>brake release board</i> on the bracket with the attachment screws. Make sure the board is positioned as straight as possible on the bracket! The push buttons can otherwise get jammed when the SMB cover is refitted.	Maximum tightening torque: 5 Nm. Shown in the figure Location of brake release board on page 183 . Art. no. is specified in Required equipment on page 184 .
4	Refit the complete brake release board (including brake release board and bracket) to the SMB recess with the two attachment screws.	
5	 <p>WARNING</p> <p>Screened cables must not get in contact with the brake release board after installation. Eliminate all risks of contact between screened cables and the brake release board.</p>	

Continues on next page

4 Repair

4.3.5 Replacing the brake release board

Continued

	Action	Note
6	Refit the <i>SMB</i> cover with its attachment screws.	Shown in the figure Location of brake release board on page 183 .
7	 WARNING Before continuing any service work, follow the safety procedure in The brake release buttons may be jammed after service work on page 150 .	
8	Refit the <i>push button guard</i> to the <i>SMB</i> cover.	Shown in the figure Location of brake release board on page 183 .
9	Press the push buttons 1 to 6, one at a time, to make sure that the buttons are moving freely and do not stay in a locked position.	
10	If the battery has been disconnected the revolution counter must be updated.	Detailed in the Calibration chapter - section Updating revolution counters on IRC5 robots on page 364 .
11	 DANGER Make sure all safety requirements are met when performing the first test run. See Test run after installation, maintenance, or repair on page 97 .	

4.3.6 Replacing the base, including axis 1 gearbox

Introduction

The term *complete arm system* used in this procedure is defined as the complete robot excluding:

- base
- gearbox axis 1

Location of the base

The location of the base, including gearbox axis 1, is shown in the figure. It also shows the complete arm system as defined above.

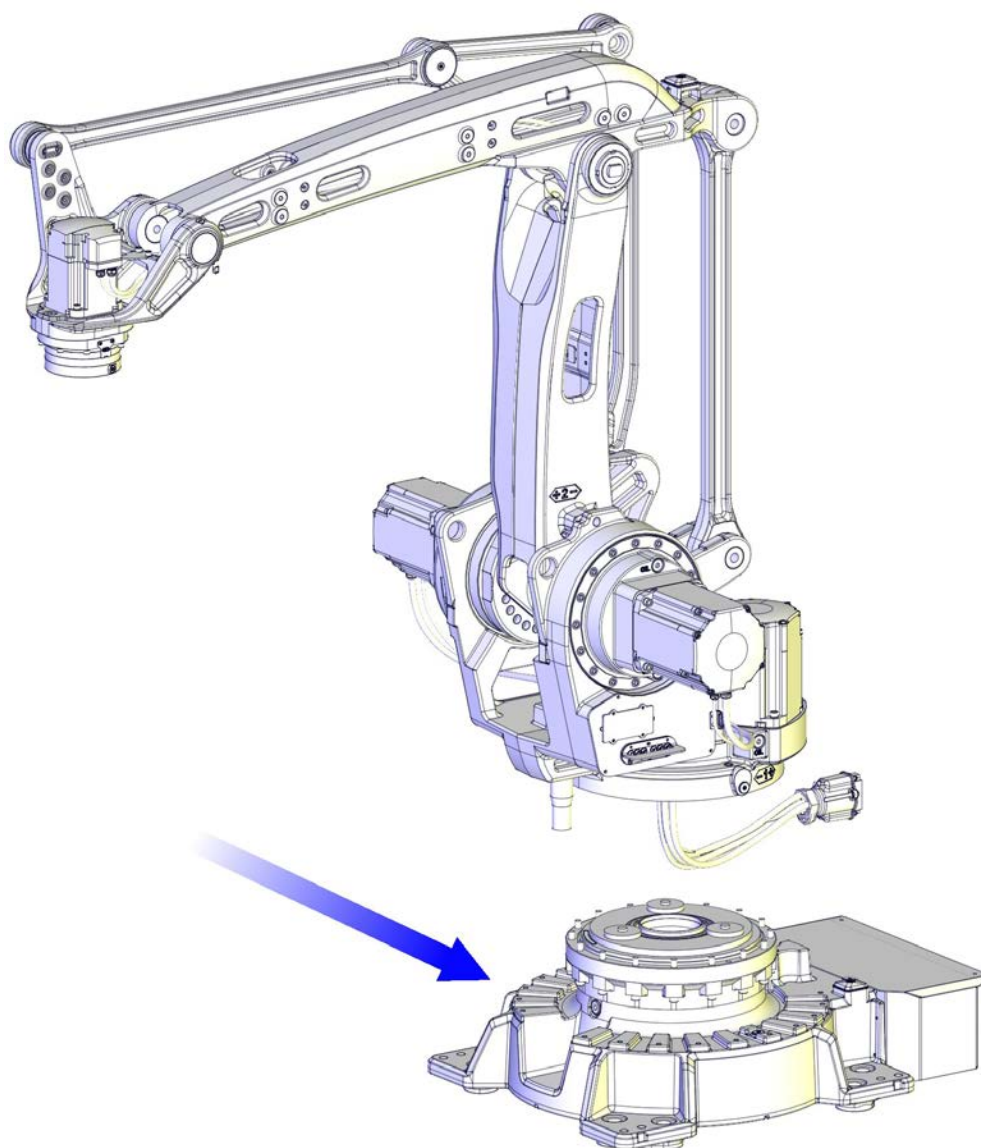

xx110000246

Continues on next page

4 Repair

4.3.6 Replacing the base, including axis 1 gearbox

Continued

Required equipment

Equipment, etc.	Art. no.	Note
Guide pins M12 x 130	3HAC022637-001	Used to guide the complete arm system when refitting. Always use the guide pins in pairs! Guide pins that are longer than 140 mm will not be possible to remove because the lack of space.
Roundsling		4 pcs. Lifting capacity 1,000 kg
Adapter	3HAC040381-001	
Lifting eye, M12	3HAC025333-005	
Shackle	-	Lifting capacity: 1,000 kg.
Bits holder	-	Stahlwille 736/40 D10 (or similar) Used on the M12x140 screws.
Power supply	-	24 VDC, max. 1.5 A For releasing the brakes.
Crank	-	Used to turn the gear when mating it to the frame.
Standard toolkit	-	Content is defined in section Standard tools on page 398 .
Other tools and procedures may be required. See references to these procedures in the step-by-step instructions below.		These procedures include references to the tools required.
Circuit diagram	-	See chapter Circuit diagrams on page 405 .

Deciding calibration routine

Decide which calibration routine to be used, based on the information in the table. Depending on which routine is chosen, action might be required prior to beginning the repair work of the robot, see the table.

	Action	Note
1	Decide which calibration routine to use for calibrating the robot. <ul style="list-style-type: none">Reference calibration. External cable packages (DressPack) and tools can stay fitted on the robot.Fine calibration. All external cable packages (DressPack) and tools must be removed from the robot.	



Continues on next page

4.3.6 Replacing the base, including axis 1 gearbox
Continued

Action	Note
<p>If the robot is to be calibrated with reference calibration: Find previous reference values for the axis or create new reference values. These values are to be used after the repair procedure is completed, for calibration of the robot. If no previous reference values exist, and no new reference values can be created, then reference calibration is not possible.</p>	<p>Follow the instructions given in the reference calibration routine on the FlexPendant to create reference values. Creating new values requires possibility to move the robot. Read more about reference calibration for Axis Calibration in Reference calibration routine on page 371.</p>
<p>If the robot is to be calibrated with fine calibration: Remove all external cable packages (DressPack) and tools from the robot.</p>	

Removing the complete arm system

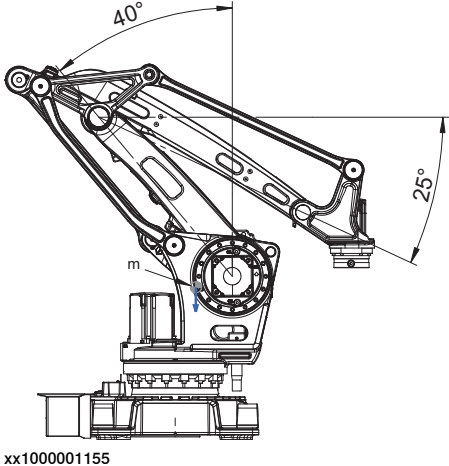
Use this procedure to remove the complete arm system.



Action	Note
1	Decide which calibration routine to use, and take actions accordingly prior to beginning the repair procedure.
2	<p>Move the robot to the transport position.</p> 
3	<p> DANGER</p> <p>Turn off all:</p> <ul style="list-style-type: none"> • electric power supply • hydraulic pressure supply • air pressure supply <p>to the robot, before entering the robot working area.</p>
4	Run an overhead crane to a position above the robot.

Continues on next page

4 Repair



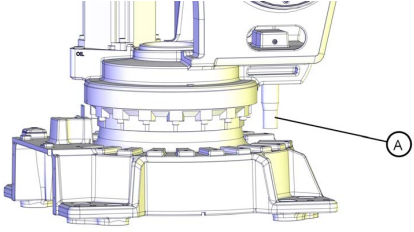

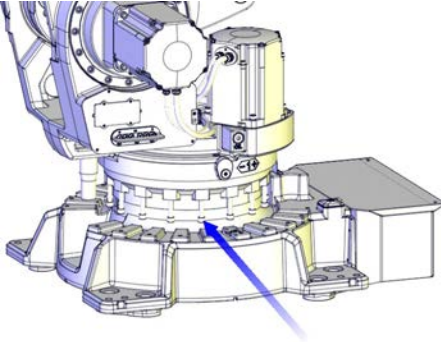
4.3.6 Replacing the base, including axis 1 gearbox

Continued

Action	Note
<p>5 Remove the mechanical stop pin from the frame.</p>	 <p>xx1000001302</p> <ul style="list-style-type: none"> A: Mechanical stop pin
<p>6 Drain the axis 1 gearbox.</p>	<p>See Changing oil, axis-1 gearbox on page 124.</p>
<p>7 Loosen the cable connectors from the base and pull up the cabling from the base, through the hole in the center of the frame.</p>	<p>See Replacing cable harness, lower end (axes 1-3) on page 151.</p>
<p>8 Remove the axis 1 motor.</p>	<p>See Replacing motor, axis 1 on page 301.</p>
<p>9  CAUTION</p> <p>The robot arm system weighs 750 kg. All lifting accessories used must be sized accordingly!</p>	
<p>10 Fit the roundslings as described in Fitting the lifting accessories to the complete arm system on page 192.</p>	
<p>11 Stretch the roundslings so that they secure the weight of the arm system.</p>	<p>Adjust the length of each roundslings so that the lift is done completely level.</p>
<p>12 Unfasten the arm system from the base by unscrewing the attachment screws.</p> <p> Note</p> <p>Use a bits holder with a thin head to remove the screws. For example Stahlwille 736/40 D10 or similar. The space is cramped.</p>	 <p>xx1100000247</p>
<p>13 Fit two <i>guide pins</i> in the holes. This will facilitate the removal of the complete arm system and prevent damage on the gearbox.</p>	<p>Article number is specified in Required equipment on page 188.</p>

Continues on next page

4.3.6 Replacing the base, including axis 1 gearbox
Continued

	Action	Note
14	<p>Lift the <i>complete arm system</i> carefully and secure it in a safe area.</p> <p> CAUTION</p> <p>The lift must be done completely level! Make sure the roundslings are adjusted prior to lifting the arm system.</p> <p> Note</p> <p>Continue lifting even if the arm system turns out to be unbalanced despite earlier adjustments! The risk of damaging the interface is bigger if the load is lowered unbalanced!</p> <p> CAUTION</p> <p>Always move the robot at very low speed, making sure it does not tip!</p>	<p> Note</p> <p>Make sure all hooks and attachments stay in the correct position while lifting the arm system and that the lifting accessory does not wear against sharp edges.</p>
15	<p>If needed, continue to remove the axis 1 gearbox from the base.</p>	<p>See Replacing the axis 1 gearbox on page 328.</p>

Continues on next page

4 Repair

4.3.6 Replacing the base, including axis 1 gearbox

Continued

Fitting the lifting accessories to the complete arm system

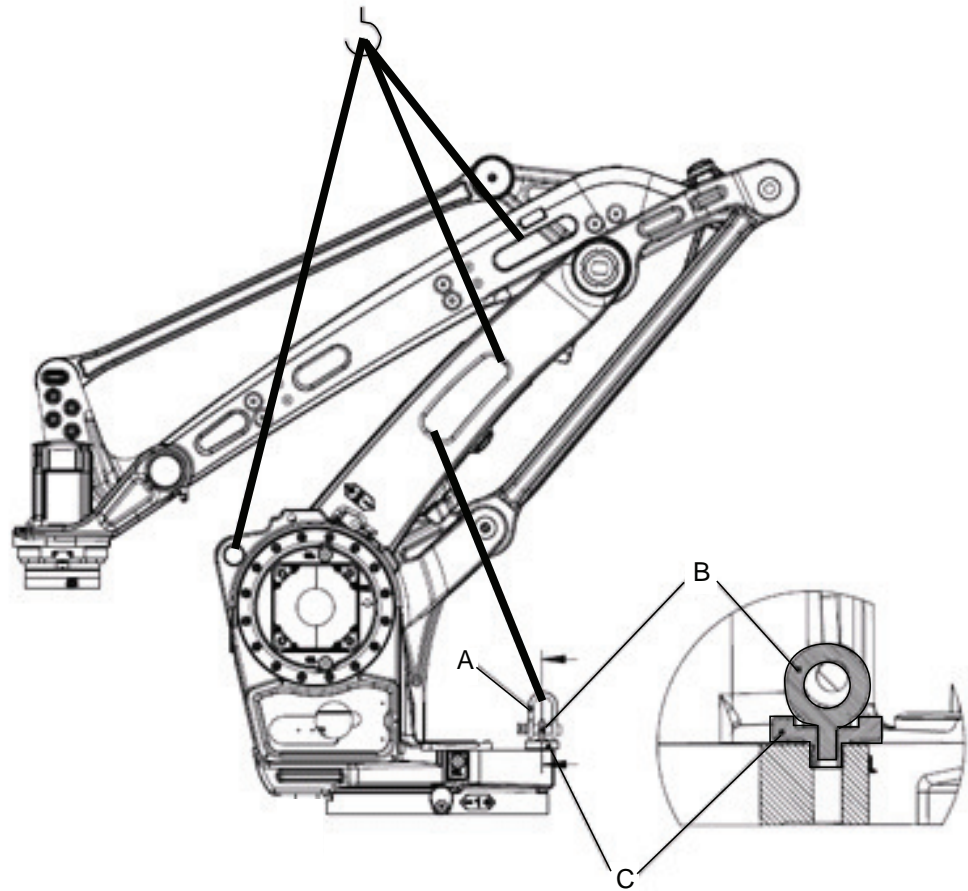

xx1100000249





- A** Shackle
- B** Lifting eye, M12
- C** Adapter

	Action	Note
1	Fit a roundsling from the frame to the overhead crane.	
2	Fit a roundsling from the lower arm to the overhead crane.	
3	Fit a roundsling from the upper arm to the overhead crane.	
4	Fit the <i>adapter</i> to the oil plug hole for filling oil into axis 1 gearbox.	Art. no. is specified in Required equipment on page 188 .
5	Fit a <i>lifting eye</i> and a <i>shackle</i> to the adapter.	Art. no. is specified in Required equipment on page 188 .
6	Fit a roundsling between the lower arm and the shackle.	The roundsling will take the load of the frame during the lift of the arm system, provided that the brake of axis 2 is released.

Continues on next page

Refitting the complete arm system

Use this procedure to refit the complete arm system.





	Action	Note
1	 DANGER Turn off all: <ul style="list-style-type: none"> • electric power supply • hydraulic pressure supply • air pressure supply to the robot, before entering the robot working area.	
2	Refit the axis 1 gearbox, if it has been removed.	See Replacing the axis 1 gearbox on page 328 .
3	 CAUTION The robot arm system weighs 750 kg. All lifting accessories used must be sized accordingly!	
4	Fit the roundslings as described in Fitting the lifting accessories to the complete arm system on page 192 .	
5	Stretch the roundslings so that they secure the weight of the arm system.	Adjust the length of each roundslings so that the lift is done completely level.
6	Lift the complete arm system and move it at very low speed to the mounting site, making sure it does not tip!  Note The refitting must be made completely level! Make sure the roundslings are adjusted prior to refitting the arm system.	 Note Make sure all hooks and attachments stay in the correct position while lifting the arm system and that the lifting accessory does not wear against sharp edges.

Continues on next page

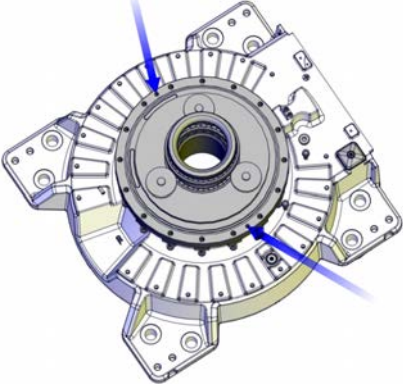

4 Repair

4.3.6 Replacing the base, including axis 1 gearbox

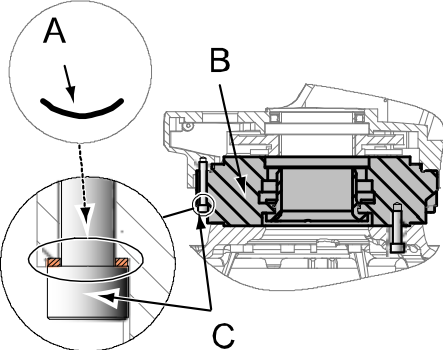
Continued

	Action	Note
7	<p>Fit two <i>guide pins</i> in the holes in the axis 1 gearbox, shown in the figure.</p> <p> Tip</p> <p>In order to make refitting easier it is recommended to use two guide pins of different lengths. Notice that longer guide pins than 140 mm will not be possible to remove after refitting because of lack of space.</p>	 <p>xx1100000257</p> <p>Dimension is specified in Required equipment on page 188.</p> <p> Note</p> <p>Always use guide pins in pairs.</p>
8	<p>Look through the empty mounting hole of the axis 1 motor to assist in aligning the assembly during refitting of the complete arm system.</p>	
9	<p>Lower the complete arm system with guidance from the guide pins previously fitted to the axis 1 gearbox.</p> <p> Note</p> <p>The refitting must be made completely level! Make sure the roundslings are adjusted prior to refitting the arm system.</p>	<p> CAUTION</p> <p>This is a complex task to be performed with utmost care in order to avoid injury or damage!</p> <p>Use a crank to turn the gearbox in order to find the right position for the holes.</p>
10	<p>Place the <i>serrated lock washers</i> on the attachment screws.</p> <p> Note</p> <p>Check that the <i>serrated lock washers</i> are turned the correct way. See figure!</p>	<p>Reused screws can be used providing they are lubricated as described in Screw joints on page 394.</p>  <p>xx0600003070</p> <p>Parts:</p> <ul style="list-style-type: none"> A Serrated lock washer (24 pcs) B Axis 1 gearbox C Attachment screws M12x110 quality 12.9 gleitmo (24 pcs)

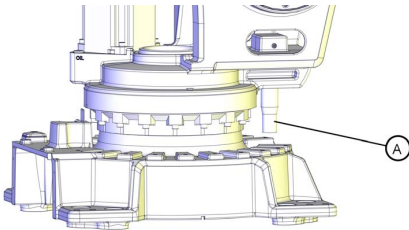
Continues on next page

Action	Note
11 Fit 14 of the 16 attachment screws before the arm system is completely lowered. This is done in order to be able to attach all screws into the threads correctly.	
12 Replace the guide pins with the remaining attachment screws and secure the complete arm system to the base with its attachment screws and washers.	
13 Lower the arm system completely.	
14 Secure the complete arm system with its <i>attachment screws</i> .	Tightening torque: • 120 Nm.
15 Refit the cable harness in the base and the frame.	See Replacing cable harness, lower end (axes 1-3) on page 151 .
16 Refit the axis 1 motor.	See Replacing motor, axis 1 on page 301 .
17 Refit the mechanical stop pin to the frame.	 <p>xx1000001302</p> <p>A: Mechanical stop pin</p>
18 Perform a leak-down test of the axis 1 gearbox.	See Performing a leak-down test on page 142 .
19 Refill the axis 1 gearbox with lubricating oil.	See Changing oil, axis-1 gearbox on page 124 .
20 Recalibrate the robot.	Axis Calibration is described in Calibrating with Axis Calibration method on page 370 . General calibration information is included in section Calibration on page 359 .
21  DANGER Make sure all safety requirements are met when performing the first test run. See Test run after installation, maintenance, or repair on page 97 .	

4 Repair

4.4.1 Replacing the turning disk

4.4 Upper and lower arm

4.4.1 Replacing the turning disk

Location of turning disk

The turning disk is located in the front of the wrist housing as shown in the figure below.

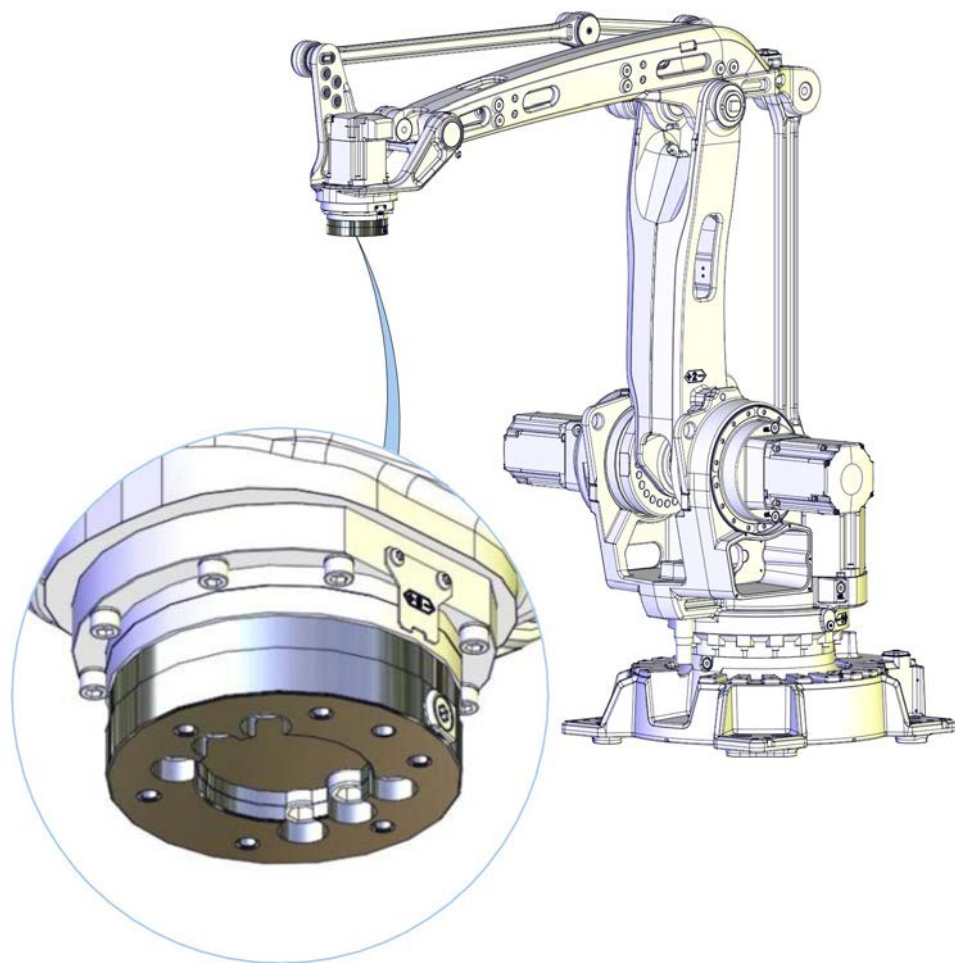

xx1100000132

Required equipment



Equipment, etc.	Art. no.	Note
Turning disk	For spare part no. see: Spare parts on page 403.	O-rings are not included!

Continues on next page

Equipment, etc.	Art. no.	Note
O-ring	3HAB3772-65 (1pc) 21520431-20 (6 pcs)	Must be replaced when replacing the turning disk!
Grease	3HAC042536-001	Shell Gadus S2 Used to lubricate the o-rings.
Flange sealant	3HAC034903-001	Loctite 574
Standard toolkit	-	Content is defined in section Standard tools on page 398 .
Other tools and procedures may be required. See references to these procedures in the step-by-step instructions below.		These procedures include references to the tools required.

Removing, turning disk

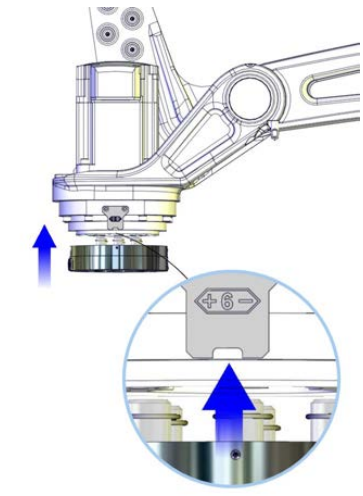
Use this procedure to remove the turning disk.

Action	Note
1 Run the robot to a position where the tilthouse is best positioned for the turning disk to be replaced.	
2 Rotate axis 6 to its calibration position.	<div style="display: flex; align-items: flex-start;"> <div style="margin-right: 10px;">  <p>Note</p> </div> <div> <p>This is done in order to facilitate fitting of the turning disk in the correct position.</p> </div> </div> <div style="text-align: center; margin-top: 10px;">  <p style="font-size: small;">xx1100000139</p> </div>
<div style="display: flex; align-items: center;">  <p>DANGER</p> </div> <p>Turn off all:</p> <ul style="list-style-type: none"> • electric power supply • hydraulic pressure supply • air pressure supply <p>to the robot, before entering the robot working area.</p>	
4 Remove any equipment fitted to the turning disk.	

Continues on next page

4 Repair

4.4.1 Replacing the turning disk

Continued

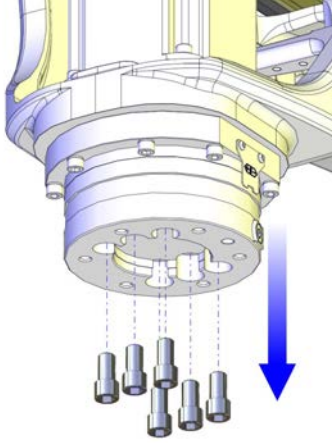
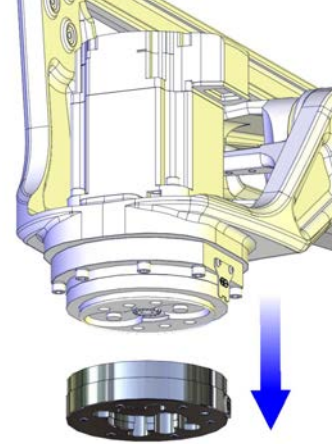
	Action	Note
5	Drain the axis 6 gearbox.	See section <ul style="list-style-type: none">• Changing oil, gearbox axis 6 on page 132
6	Remove the <i>attachment screws</i> that secure the turning disk.	 <p data-bbox="1043 913 1155 936">xx110000075</p> <p data-bbox="1043 952 1398 1014">Shown in the figure Location of turning disk on page 196.</p>
7	Remove the <i>turning disk</i> .	 <p data-bbox="1043 1529 1155 1552">xx110000076</p>
8	Foundry Plus: Remove old flange sealant residues and other contamination from the contact surfaces.	

Continues on next page

Refitting, turning disk

Use this procedure to refit the turning disk.

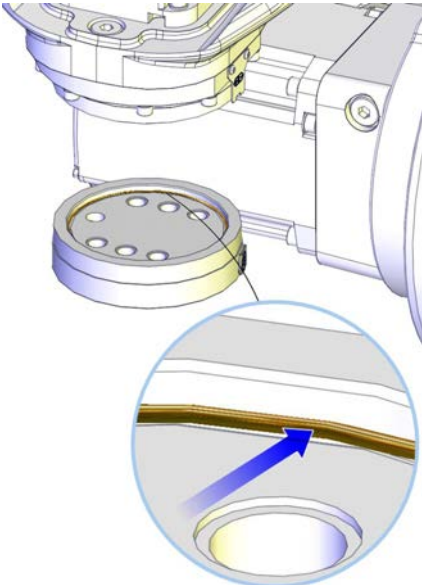
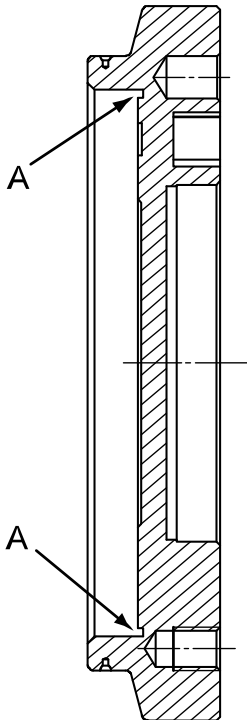
	Action	Note
1	Lubricate the <i>o-ring</i> of the turning disk with <i>grease</i> and fit it to the turning disk.	<p>Art. no. is specified in <i>Required equipment on page 196</i>.</p>  <p>xx1100000140</p>  <p>xx0200000218</p> <ul style="list-style-type: none"> • A: Sealing surface, o-ring

Continues on next page



4 Repair

4.4.1 Replacing the turning disk

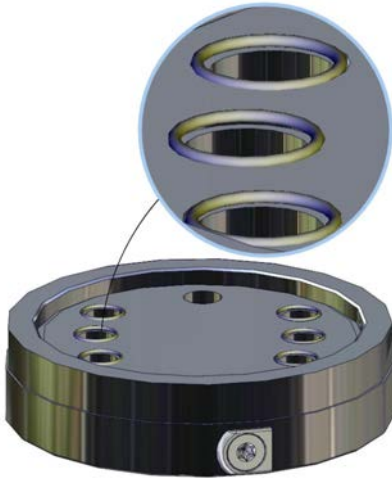
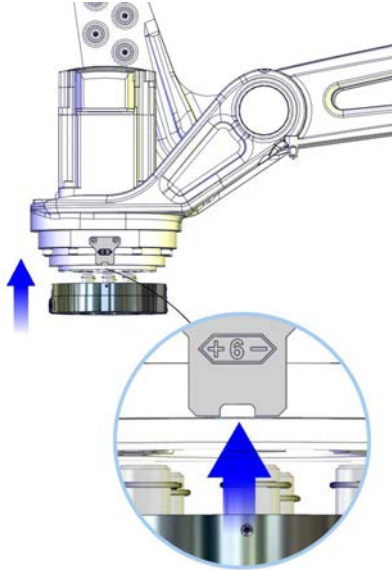
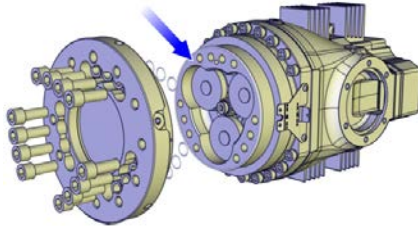
Continued

	Action	Note
2	Put some grease on the <i>o-rings</i> (6 pcs) and fit them in turning disk as shown in the figure.	 <p data-bbox="981 907 1093 929">xx110000080</p>
3	Locate the calibration mark on the turning disk and place the turning disk at the tilthouse so that the calibration mark matches the calibration scale at the tilthouse. The hole pattern of the turning disk allows the turning disk to be fitted in three different rotated positions. Matching the calibration marks guarantees that the turning disk is fitted at the correct turn, provided that the axis 6 was set in calibration position before the turning disk was removed!	 <p data-bbox="981 1556 1093 1579">xx1100000139</p>
4	Foundry Plus: Apply Loctite 574 flange sealant on the contact surface.	 <p data-bbox="981 1877 1093 1899">xx1400000995</p>

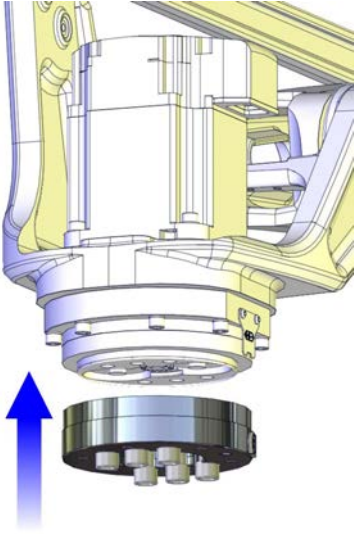
Continues on next page

	Action	Note
5	Secure the turning disk with its <i>attachment screws</i> .	 <p>xx110000078</p> <p>Attachment screws M10x25 quality 12.9 (6 pcs)</p> <p>Tightening torque:</p> <ul style="list-style-type: none"> • 175 Nm <p>Reused screws may be used, providing they are lubricated as detailed in section Screw joints on page 394 before fitting.</p>
6	Perform a <i>leak-down test</i> of the gearbox axis 6.	Detailed in the section Performing a leak-down test on page 142 .
7	Refill the axis 6 gearbox with oil.	See section <ul style="list-style-type: none"> • Changing oil, gearbox axis 6 on page 132
8	Refit any equipment removed during disassembly to the turning disk.	
9	 <p>DANGER</p> <p>Make sure all safety requirements are met when performing the first test run. See Test run after installation, maintenance, or repair on page 97.</p>	

4 Repair

4.4.2 Replacing the tilthouse unit

4.4.2 Replacing the tilthouse unit

Introduction

This section describes how to replace the tilthouse unit. The section consists of these parts:

- [Location of tilthouse unit on page 203](#)
- [Location of axes 2 and 3 sides of the robot on page 204](#)
- [X-ray view of the assembly of the tilthouse unit on page 206](#)
- [Press tool for removal of shaft on page 207](#)
- [Removing the tilthouse unit on page 210](#)
- [Premounting outer race of bearing and radial sealing, axis 2 side on page 216](#)
- [Premounting outer race of bearing and radial sealing, axis 3 side on page 217](#)
- [Refitting shafts on page 218](#)
- [Refitting lock nuts and the remaining parts on page 220](#)

Continues on next page

Location of tilthouse unit

The tilthouse unit is located as shown in the figure.

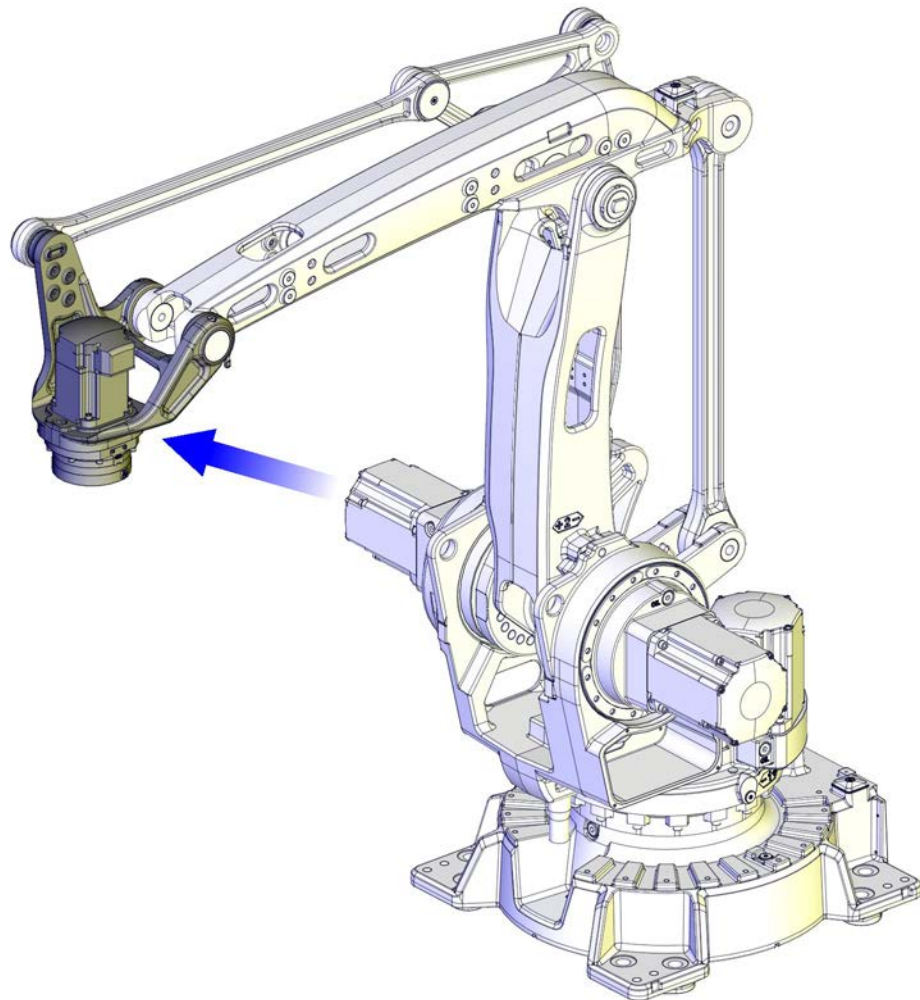

xx110000213

Continues on next page

4 Repair

4.4.2 Replacing the tilthouse unit

Continued

Location of axes 2 and 3 sides of the robot

The figures shows the location of the axes 2 and 3 sides of the robot. See markings on the lower arm (*axis 2*) and the parallel arm (*axis 3*). These two sides of the robot will be referred to in the replacing procedures.

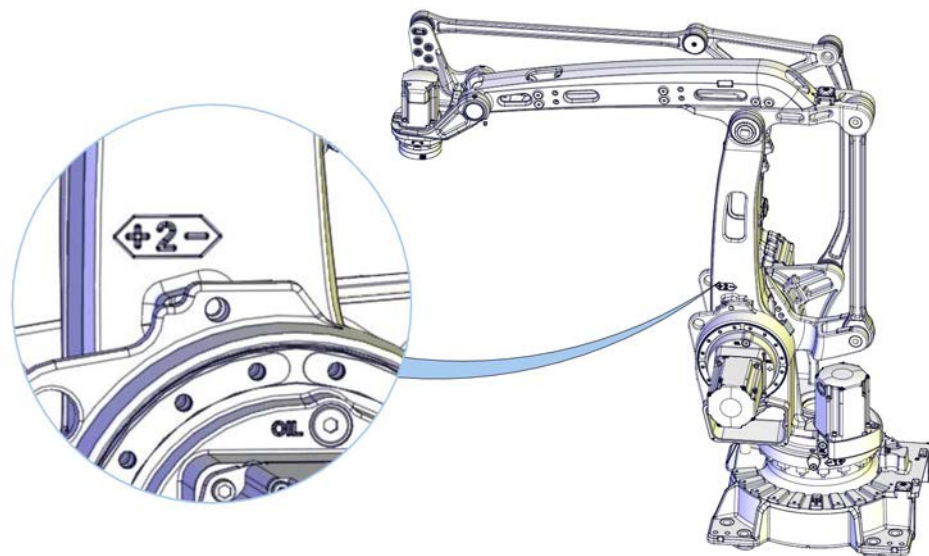

xx110000214

Axis 2 side (See marking on lower arm)

Continues on next page

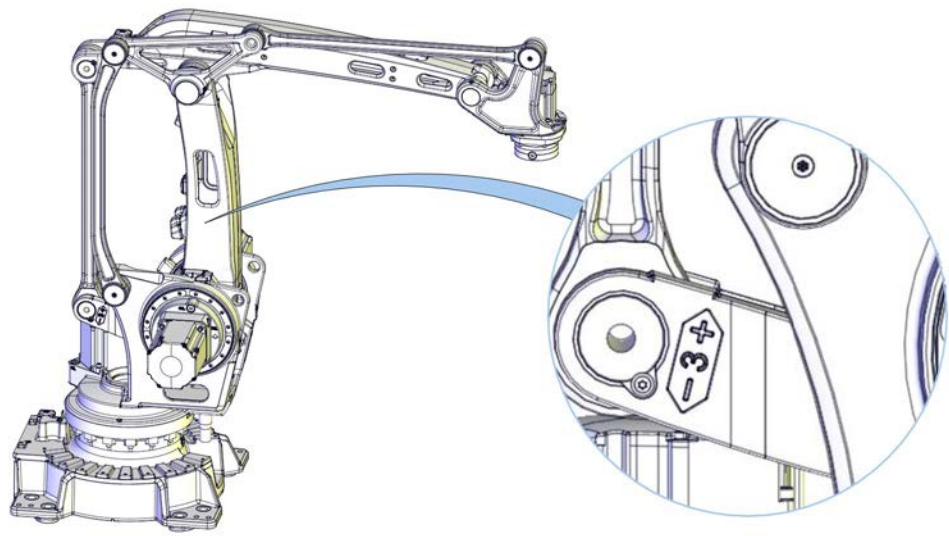

xx110000215

Axis 3 side (See marking on parallel arm)

Continues on next page

4 Repair

4.4.2 Replacing the tilthouse unit

Continued

X-ray view of the assembly of the tilthouse unit

The figure shows a X-ray view of how the tilthouse unit is fitted to the upper arm. Both sides looks the same.

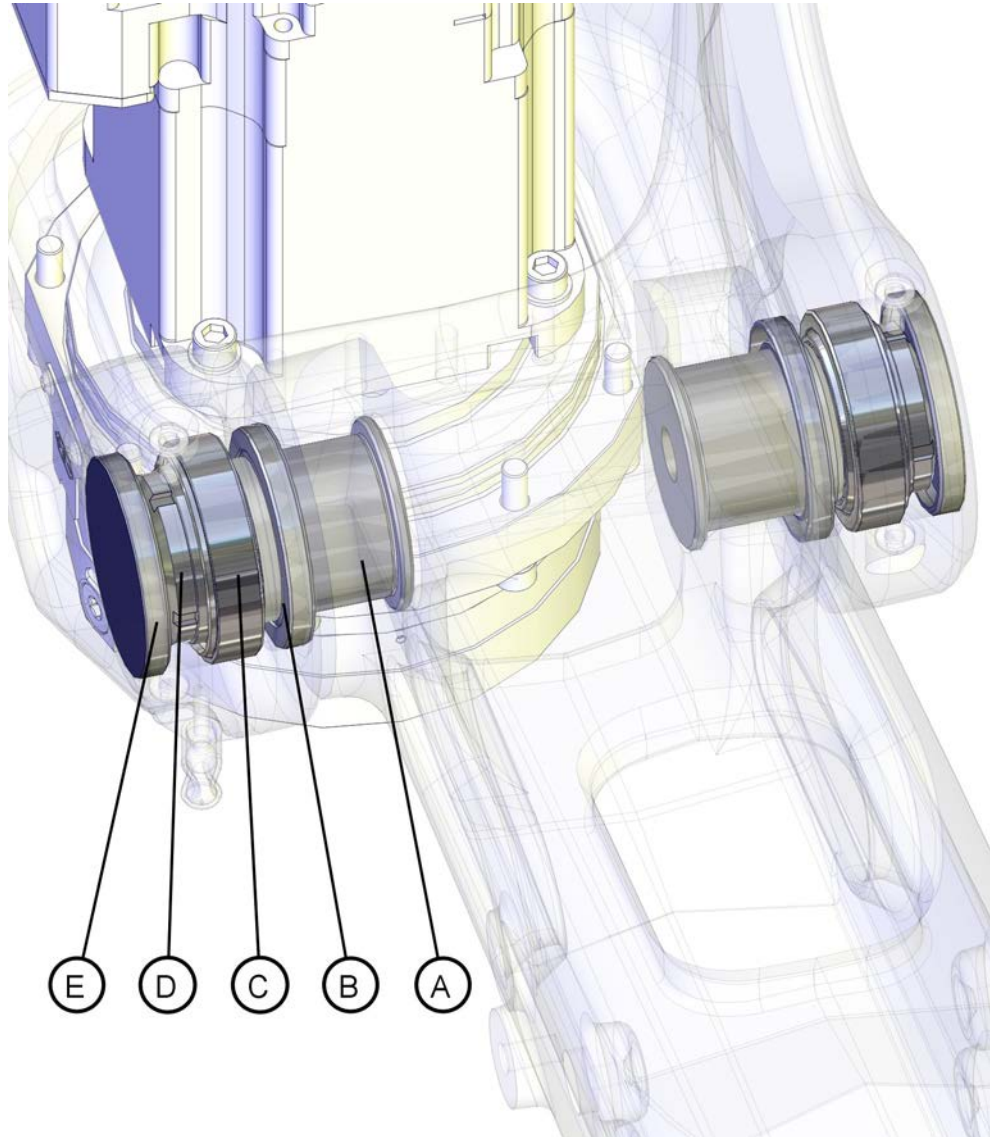

xx110000216

- A Shaft
- B Radial sealing
- C Bearing
- D Lock nut
- E VK cover 65x8
VK cover 19x6 (Inside VK cover 65x8), not shown in this figure

Required equipment

Equipment, etc.	Art.no.	Note
VK cover	Spare parts on page 403	VK 19x6 (2 pcs)

Continues on next page

Equipment, etc.	Art.no.	Note
VK cover	Spare parts on page 403	VK 65x8 (2 pcs)
Sealing ring	3HAB3701-19	D=70/85 T=8 (2 pcs)
Taper roller bearing	3HAA2103-25	
Press tool, premounting outer race bearing	3HAC077982-001	Hydraulic pressing accessory. User instructions are enclosed with the tool.
Press tool, replacing shaft	3HAC040029-001	Used for assembly and disassembly.
Auxiliary shaft	3HAC040035-001	Used for disassembly of shaft.
KM7 socket	3HAC040025-001	
Grease	3HAB3537-1	
Rust preventive		Dinitrol 490
Locking liquid	3HAB7116-1	Loctite 243
Standard toolkit	-	Content is defined in section Standard tools on page 398 .
Other tools and procedures may be required. See references to these procedures in the step-by-step instructions below.		These procedures include references to the tools required.

Press tool for removal of shaft

The *press tool replacing shaft* is used both for removal and refitting. See figure how to use the tool depending on purpose. For art. no. see [Required equipment on page 206](#).

The *press tool replacing shaft* and *auxiliary bushing* applied as shown in the figure is used to disassemble the shaft.

Continues on next page

4 Repair

4.4.2 Replacing the tilthouse unit

Continued

The press tool consists of the parts shown in the figure.

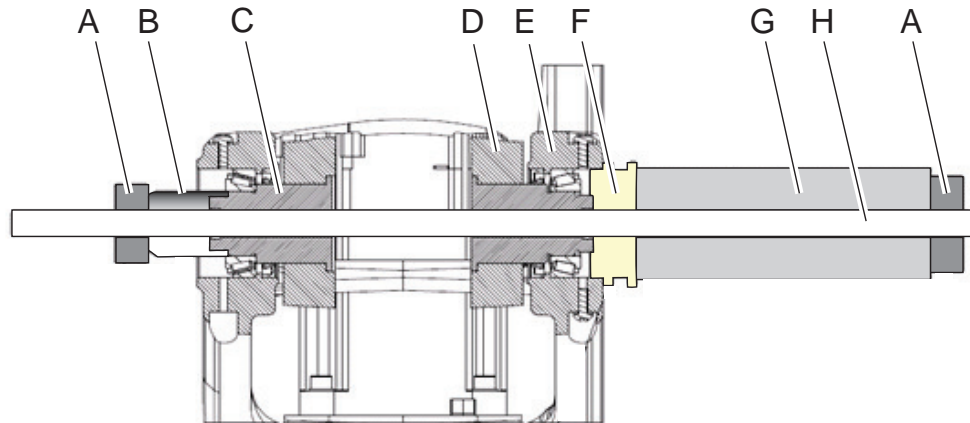

xx1100000252

- | | |
|---|--|
| A | Thread washer (2 pcs) |
| B | Auxiliary shaft (3HAC040035-001) Only used on removal. |
| C | Shaft axis 2 |
| D | Upper arm |
| E | Tilthouse |
| F | Support bushing (3HAC040029-002) |
| G | Hydraulic cylinder |
| H | Threaded bar M16 |

Press tool for fitting of shaft

The *press tool replacing shaft* is used both for removal and refitting. See figure how to use the tool depending on purpose. For art. no. see [Required equipment on page 206](#).

The *press tool replacing shaft* applied as shown in the figure is used to fit the shaft. The press tool consists of the parts shown in the figure. **NOTE!** The thread washer

Continues on next page

(shown as A) in the figure must be used when fitting the shaft. If not the shaft will not be pressed in completely.

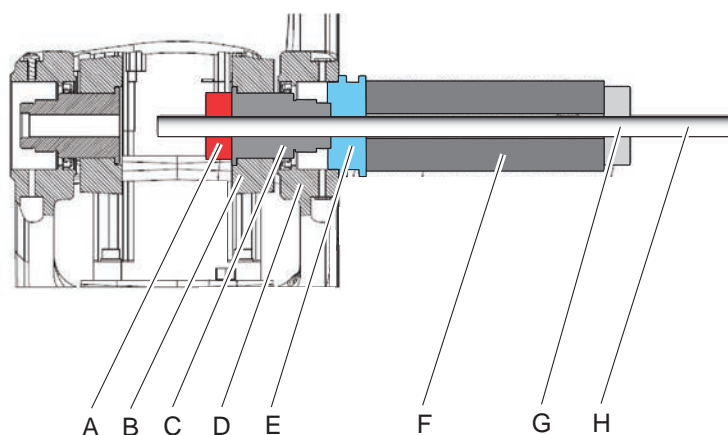

xx110000256

A	Thread washer, 3HAC040029-001
B	Upper arm
C	Shaft axis 3
D	Tilthouse
E	Support bushing
F	Hydraulic cylinder
G	Thread washer
H	Threaded bar M16

Deciding calibration routine

Decide which calibration routine to be used, based on the information in the table. Depending on which routine is chosen, action might be required prior to beginning the repair work of the robot, see the table.

	Action	Note
1	Decide which calibration routine to use for calibrating the robot. <ul style="list-style-type: none"> Reference calibration. External cable packages (DressPack) and tools can stay fitted on the robot. Fine calibration. All external cable packages (DressPack) and tools must be removed from the robot. 	

Continues on next page

4 Repair

4.4.2 Replacing the tilthouse unit

Continued



Action	Note
<p>If the robot is to be calibrated with reference calibration: Find previous reference values for the axis or create new reference values. These values are to be used after the repair procedure is completed, for calibration of the robot.</p> <p>If no previous reference values exist, and no new reference values can be created, then reference calibration is not possible.</p>	<p>Follow the instructions given in the reference calibration routine on the FlexPendant to create reference values.</p> <p>Creating new values requires possibility to move the robot.</p> <p>Read more about reference calibration for Axis Calibration in Reference calibration routine on page 371.</p>
<p>If the robot is to be calibrated with fine calibration: Remove all external cable packages (DressPack) and tools from the robot.</p>	

Removing the tilthouse unit

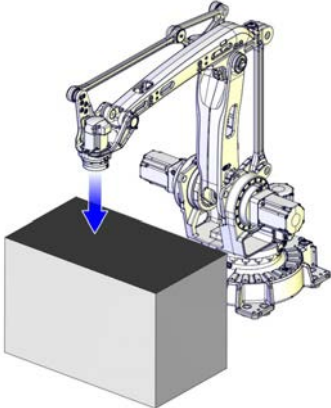
Use this procedure to remove the tilthouse unit.

Action	Note
1	Decide which calibration routine to use, and take actions accordingly prior to beginning the repair procedure.
2	<p>Move the robot to a position where the tilthouse rests on a workbench, pallets or similar.</p> <div style="text-align: right;">  <p>xx1100000225</p> </div>

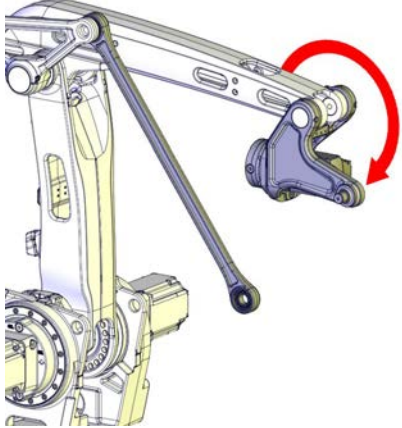
Continues on next page

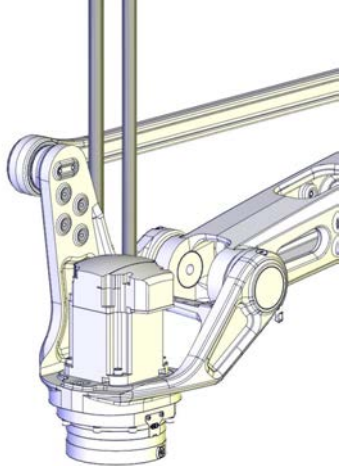
	Action	Note
3	<p>This is done in order to prevent the tilthouse from falling down when the upper link is removed.</p> <p> DANGER</p> <p>If not secured the tilthouse will fall down when the upper link is removed. See figure!</p>	 <p>xx1100000226</p>
4	<p> DANGER</p> <p>Turn off all:</p> <ul style="list-style-type: none"> • electric power supply • hydraulic pressure supply • air pressure supply <p>to the robot, before entering the robot working area.</p>	
5	<p>Secure the tilthouse with a <i>roundsling</i> in an overhead crane or similar.</p>	 <p>xx1100000227</p>
6	<p>Disconnect <i>motor cables</i> from motor axis 6. Place the motor cables in a way that it will not be damaged.</p>	<p>See Replacing motor, axis 6 on page 320</p>

Continues on next page



4 Repair

4.4.2 Replacing the tilthouse unit

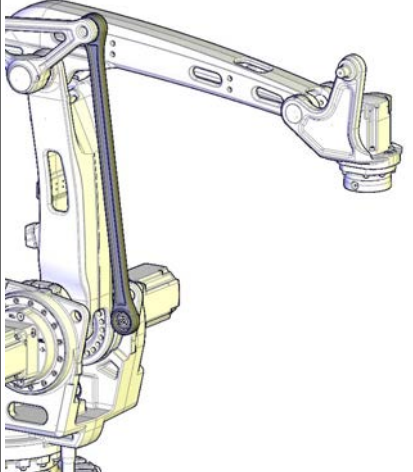
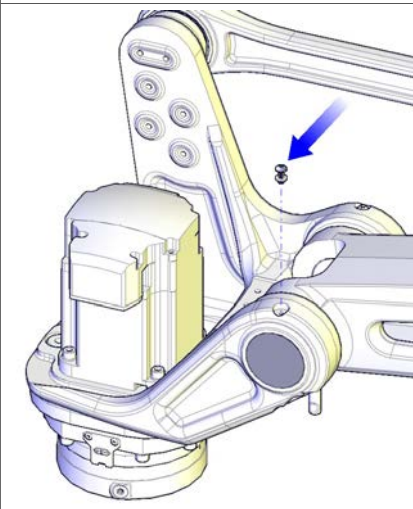
Continued

	Action	Note
7	<p>Disassemble the <i>upper link arm</i> from the tilthouse unit.</p> <p> Note</p> <p>It is not needed to remove the upper link from the link.</p>	<p>See Replacing linkage - upper link arm on page 240</p>  <p>xx1100000228</p>
8	<p>Remove one of the <i>M6 screws and washer</i> for filling grease.</p>	 <p>xx1100000230</p>

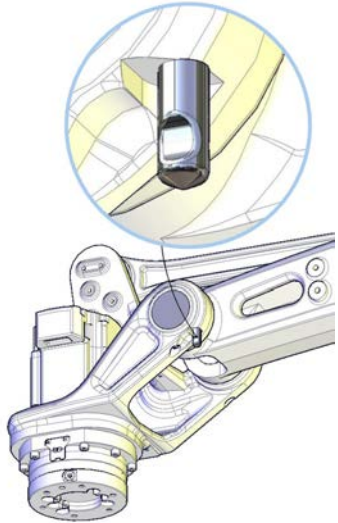
Continues on next page

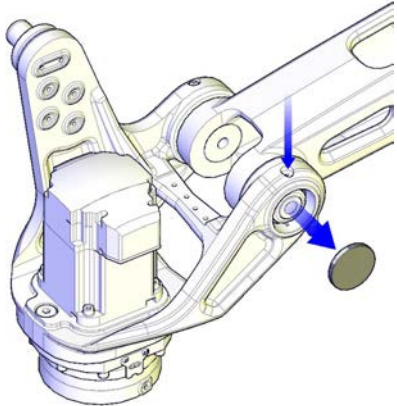

	Action	Note
9	<p>Be careful not to damage the <i>ball plug</i>!</p> <p> Note</p> <p>Do not remove the ball plug!</p>	 <p>xx110000231</p>
10	<p>Remove one shaft at a time by following the steps below, starting on axis 2 side.</p>	
11	<p>Use compressed air in the M6 hole for filling grease, in order to remove the VK cover.</p> <p>Put a hand with some paper over the VK cover in order to catch it.</p> <p> CAUTION</p> <p>Only a very low air pressure is needed!</p>	 <p>xx110000232</p>

Continues on next page

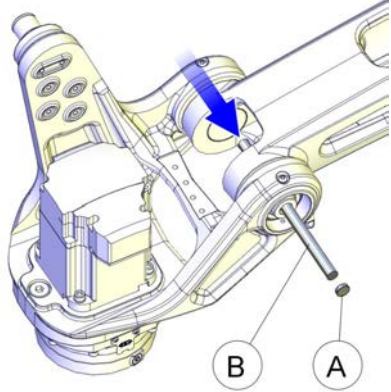
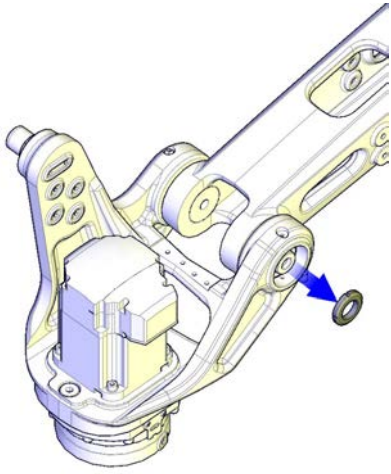

4 Repair

4.4.2 Replacing the tilthouse unit

Continued

	Action	Note
12	Remove the <i>small VK cover</i> from the inside with the help of a short punch or similar.	 <p>xx110000233</p> <p>Parts: A: VK cover B: Punch</p>
13	Remove the <i>lock nut</i> .	 <p>xx110000234</p>
14	Apply the <i>press tool shaft</i> and <i>auxiliary bushing</i> used for removing the shaft, as shown in the figure in: <ul style="list-style-type: none">• Press tool for removal of shaft on page 207  Note A longer threaded bar M16 is needed when removing the shaft than the one specified when fitting.	For art.no:s. see Required equipment on page 206 . The longer threaded bar: M16 length 450 mm

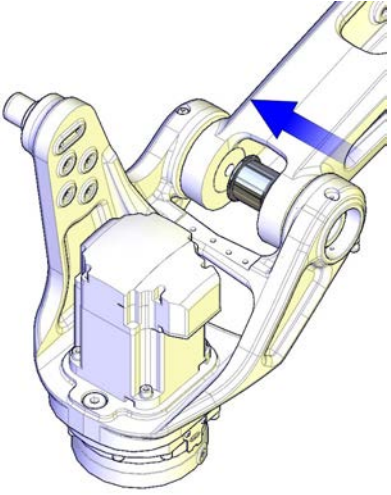
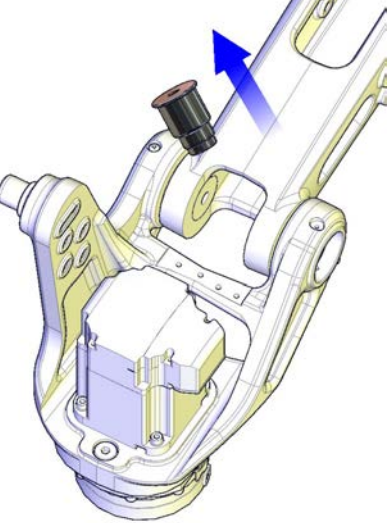
Continues on next page

	Action	Note
15	Press out the <i>shaft</i> with the press tool.	 <p>xx110000235</p>
16	Remove the <i>press tool shaft</i> and the <i>shaft</i> .	 <p>xx110000236</p>
17	Check that the tilthouse is secured in an overhead crane or similar before proceeding with the next shaft.	
18	Remove the shaft on the axis 3 side in the same way by following the steps above.	
19	 CAUTION The robot tilt house weighs 50 kg. All lifting accessories used must be sized accordingly!	

Continues on next page

4 Repair

4.4.2 Replacing the tilthouse unit

Continued

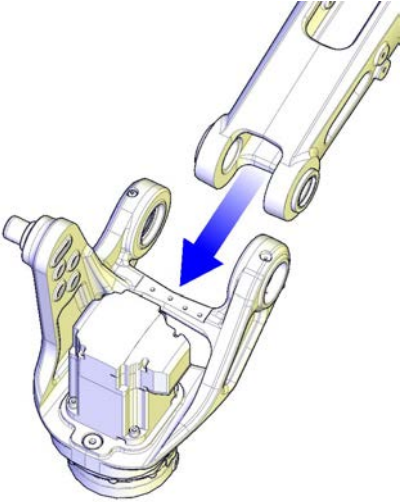
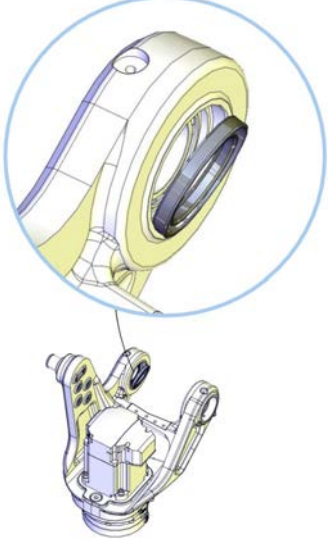

	Action	Note
20	Remove the tilthouse and lift it to a safe place. Check that bearings are kept clean. Replace if damaged.	 <p data-bbox="991 891 1102 909">xx110000237</p>
21	Force away the <i>sealing ring</i> with a screwdriver or similar. The sealing ring must be replaced with new ones when refitting.	 <p data-bbox="991 1525 1102 1543">xx110000243</p>
22	If needed replace bearings.	

Premounting outer race of bearing and radial sealing, axis 2 side

Use this procedure to fit the outer race of the bearing and radial sealing in the tilthouse on the axis 2 side, before fitting the tilthouse to the upper arm.

	Action	Note
1	This work is best done on a workbench or similar.	
2	Fit the <i>radial sealing</i> in the hole.	
3	Apply some <i>grease</i> in the hole for the <i>bearings</i> .	Art.no. is specified in Required equipment on page 206 .

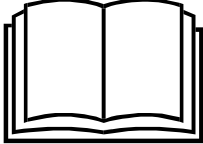
Continues on next page

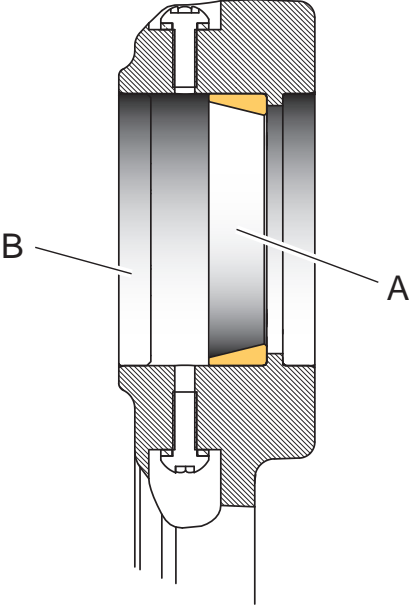
	Action	Note
4	<p>Fit the outer race of the bearing. Normally this can be done by hand. If needed apply the <i>press tool pre-mounting bearing</i> and fit the <i>outer race</i> of the bearing.</p>  <p>xx0900000813</p> <p>Go to the user instructions enclosed with the press tool.</p> <p> DANGER</p> <p>Handling the tool incorrectly will cause serious injury. Read and follow enclosed user instructions for the tool.</p>	<p>For art.no. see Required equipment on page 206.</p> <p> Note</p> <p>Check that the races are turned the correct way!</p>  <p>xx1100000244</p> <p>Parts: A: Surface for VK cover B: Outer race bearing axis 2 side</p>
5	<p>Apply grease on the inner diameter of the <i>radial sealing</i>.</p>	<p>Also see</p>

Premounting outer race of bearing and radial sealing, axis 3 side

Use this procedure to fit the outer race of the bearing and radial sealing in the tilthouse on the axis 3 side, before fitting the tilthouse to the upper arm.



	Action	Note
1	<p>This work is best done on a workbench or similar.</p>	
2	<p>Fit the <i>radial sealing</i> in the hole.</p>	<p>See X-ray view of the assembly of the tilthouse unit on page 206.</p>
3	<p>Apply some <i>grease</i> in the hole for the <i>bearings</i>.</p>	<p>Art.no. is specified in Required equipment on page 206.</p>

Continues on next page

4 Repair

4.4.2 Replacing the tilthouse unit

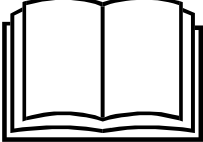
Continued

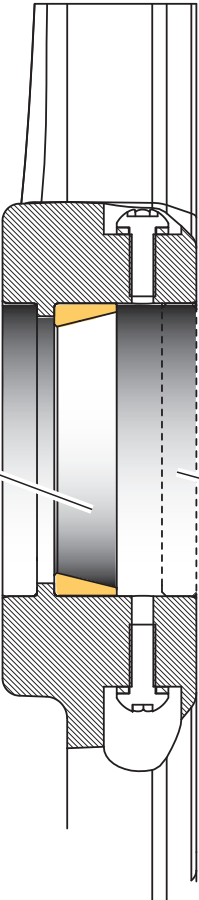
	Action	Note
4	<p>Fit the outer race of the bearing. Normally this can be done by hand. If needed apply the <i>press tool pre-mounting bearing</i> and fit the <i>outer race</i> of the bearing.</p>  <p>xx0900000813</p> <p>Go to the user instructions enclosed with the press tool.</p> <p> DANGER</p> <p>Handling the tool incorrectly will cause serious injury. Read and follow enclosed user instructions for the tool.</p>	<p>Art.no. specified in Required equipment on page 206.</p>  <p>xx1100000245</p> <p>Parts: A: Outer race bearing axis 3 side B: Surface for VK cover</p>
5	<p>Apply <i>grease</i> on the inner diameter of the <i>radial sealing</i>.</p>	<p>See X-ray view of the assembly of the tilthouse unit on page 206.</p>

Refitting shafts



Before starting this procedure, prepare the tilthouse as described in:

- [Premounting outer race of bearing and radial sealing, axis 2 side on page 216](#)
- [Premounting outer race of bearing and radial sealing, axis 3 side on page 217](#)

Use this procedure to refit the shafts of the tilthouse unit.

	Action	Note
1	<p> CAUTION</p> <p>The robot tilt house weighs 50 kg. All lifting accessories used must be sized accordingly!</p>	

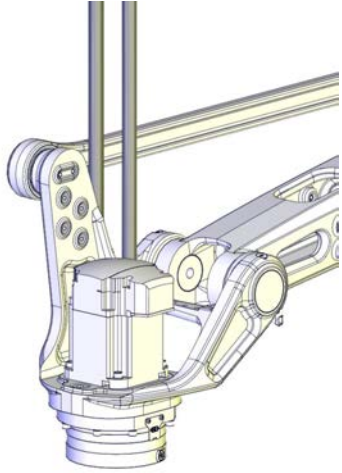
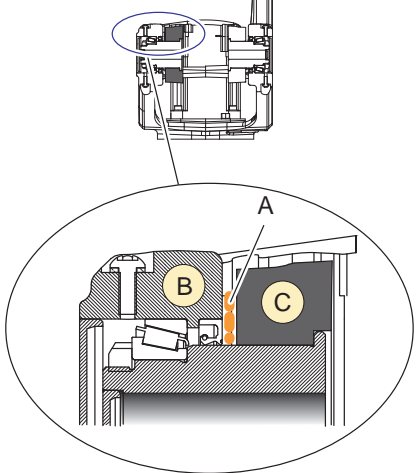
Continues on next page

	Action	Note
2	Secure the tilthouse with a <i>roundsling</i> in an overhead crane or similar and lift it to its mounting position on the upper arm and let it rest on a workbench, some pallets or similar (as when removing it).	 <p>xx110000227</p>
3	Apply <i>rust preventive (Dinitrol 490)</i> on the surface where the tilthouse faces the upper arm.	 <p>xx110000248</p> <p>Parts: A: Dinitrol 490 B: Tilthouse C: Upper arm</p>
4	Apply some <i>grease</i> in the hole for the <i>shaft</i> in the upper arm.	Art. no. is specified in Required equipment on page 206 .
5	 Note Refit the axis 2 side first!	See Location of axes 2 and 3 sides of the robot on page 204 .

Continues on next page

4 Repair

4.4.2 Replacing the tilthouse unit

Continued

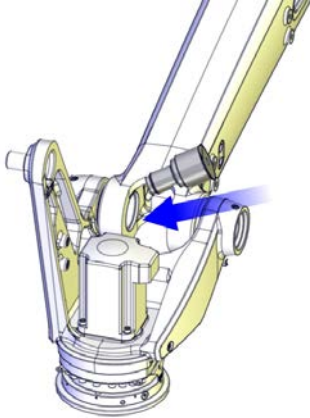
	Action	Note
6	Push the <i>shaft</i> into its hole, from the inside.	<p>The figure shows IRB 760 but the principle is the same.</p>  <p>xx1000001438</p>
7	Align the holes in the upper arm and tilthouse as close as possible.	
8	<p>Apply the <i>press tool shaft</i> prepared for refitting the shaft, as shown in the figure in:</p> <p>NOTE! Use the correct thread washer pressing against the shaft. See figure! If the correct thread washer isn't used, the shaft will not be pressed in completely.</p> <ul style="list-style-type: none"> • Press tool for fitting of shaft on page 208. 	
9	Press the parts together.	
10	Fit the axis 3 side in the same way, by following the steps above.	

Refitting lock nuts and the remaining parts





Before starting this procedure, perform the procedure:

- [Refitting shafts on page 218](#)

Use this procedure to refit the lock nuts and the other remaining parts of the tilthouse unit.

	Action	Note
1	 Note Start the assembly on the axis 2 side!	

Continues on next page

	Action	Note
2	Place the <i>inner race of the bearing</i> on the shaft on the axis 2 side and push it in position.  Note Normally it shall be possible to fit the bearing into position very easy.	
3	Apply <i>locking liquid (Loctite 243)</i> on the threads of the lock nut KM7.	
4	Secure the axis 2 shaft with the <i>lock nut</i> .  Note Flat side of the lock nut facing inwards!	Tightening torque: • 90 Nm
5	Place the <i>inner race of the bearing</i> on the shaft on the axis 3 side and push it in position.  Note Normally it shall be possible to fit the bearing into position very easy.	
6	Apply <i>locking liquid (Loctite 243)</i> on the threads of the lock nut KM7.	
7	Secure the axis 3 shaft with the lock nut.  Note Flat side of the lock nut facing inwards!	Tightening torque: 90 Nm.  Note Rotate the tilthouse while securing the lock nut on the axis 3 side.
8	Wipe clean the surfaces for the VK-covers with Isopropanol.	
9	Fit the small <i>VK covers</i> on axes 2 and 3 using a plastic mallet.	
10	Fit the big VK covers on axes 2 and 3 using a plastic mallet.	
11	Fill bearings with <i>grease</i> by removing both M6 screws on either side. One hole is used for filling and the other for letting out air. Fill until grease spills out of the air hole.	
12	Fit the <i>M6 screws</i> and <i>washers</i> covering the grease filling holes.	
13	Refit the <i>upper link arm</i> .	See Replacing linkage - upper link arm on page 240
14	Refit the <i>motor cable, axis 6</i> .	See Replacing motor, axis 6 on page 320

Continues on next page

4 Repair

4.4.2 Replacing the tilthouse unit

Continued

	Action	Note
15	Recalibrate the robot.	Axis Calibration is described in Calibrating with Axis Calibration method on page 370 . General calibration information is included in section Calibration on page 359 .
16	 DANGER Make sure all safety requirements are met when performing the first test run. See Test run after installation, maintenance, or repair on page 97 .	

4.4.3 Replacing the upper arm

Location of the upper arm

The upper arm is located as shown in the figure.

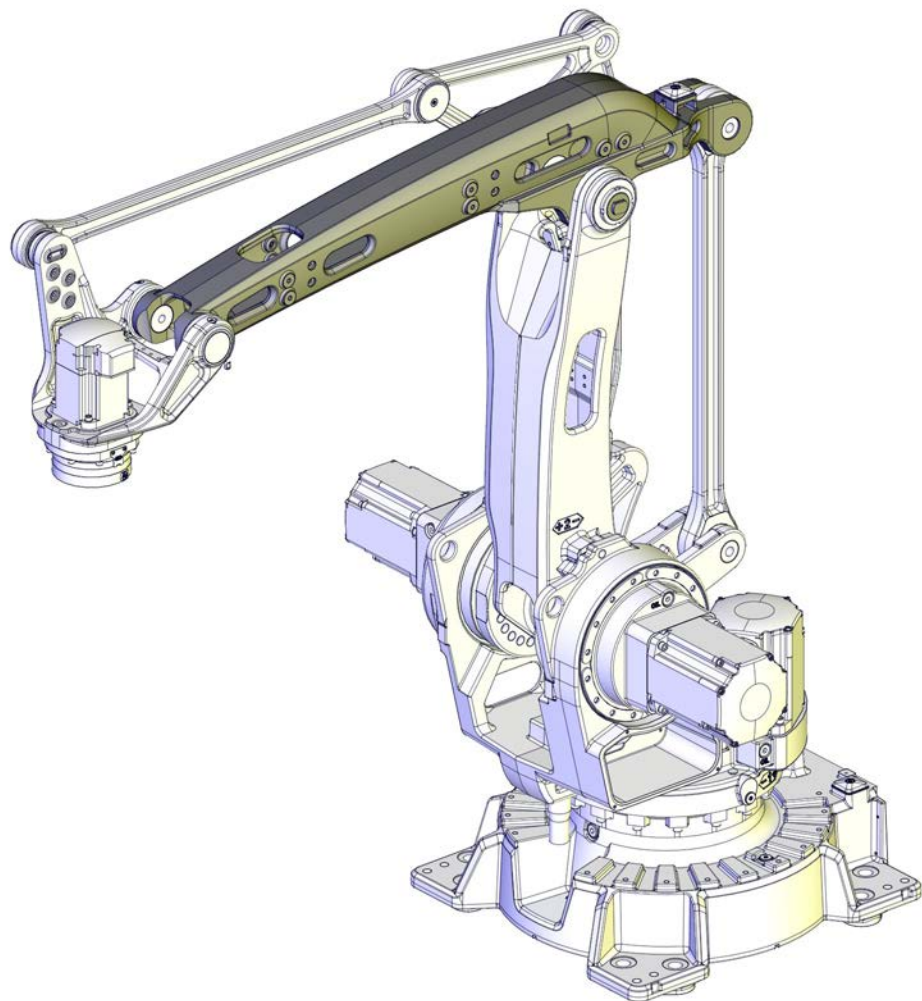

xx1100000262

Different versions of the sealing structure

Robots that are delivered from October 2012 and forward has a new sealing structure at the link that consists of a support ring, o-ring and radial sealing.

Robots delivered before October 2012 has a sealing structure that consists of a POM sealing, if not updated with the new sealing structure according to above.

The removal and refitting procedures describe both versions of sealing structures. The steps that differ are marked with information about which sealing structure the step is valid for.

Continues on next page

4 Repair

4.4.3 Replacing the upper arm

Continued

Cut away view of the assembly of the upper arm components

The figure shows a cut away view how the upper arm is fitted to the lower arm.

Design with POM sealing

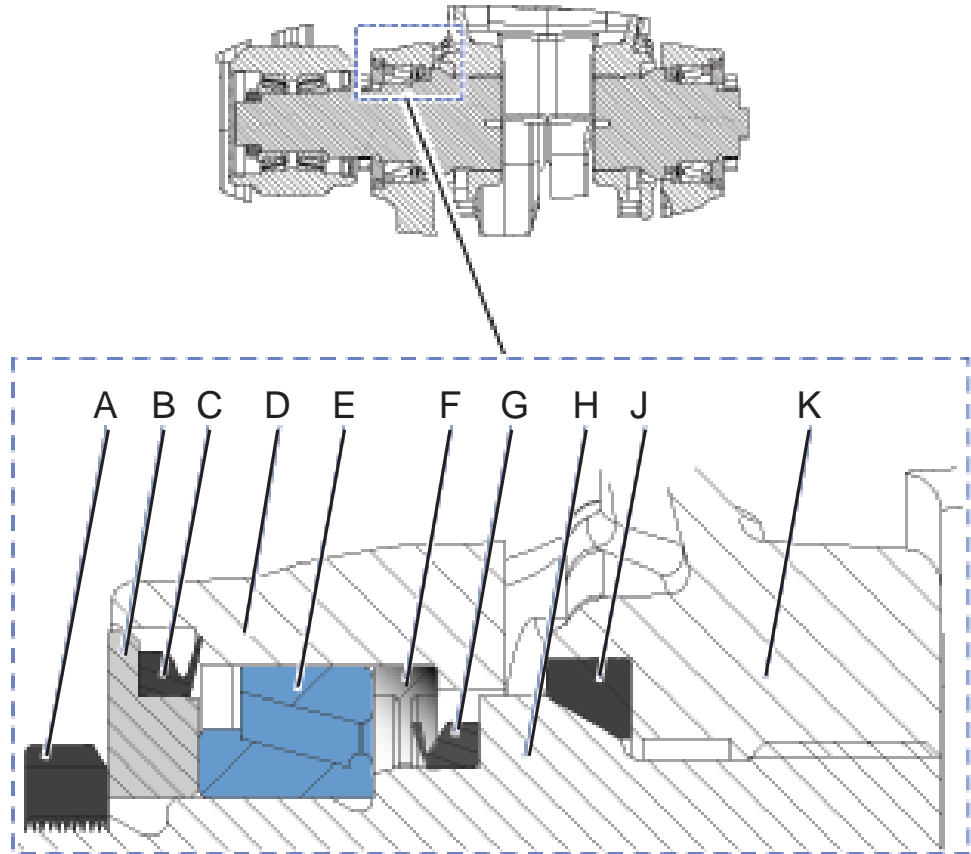

xx110000273

A	Lock nut
B	Support ring
C	Sealing ring (V-ring)
D	Lower arm
E	Bearing
F	T-ring
G	Sealing ring (V-ring)
H	Shaft
J	Bushing
K	Upper arm

Continues on next page

Design with support ring

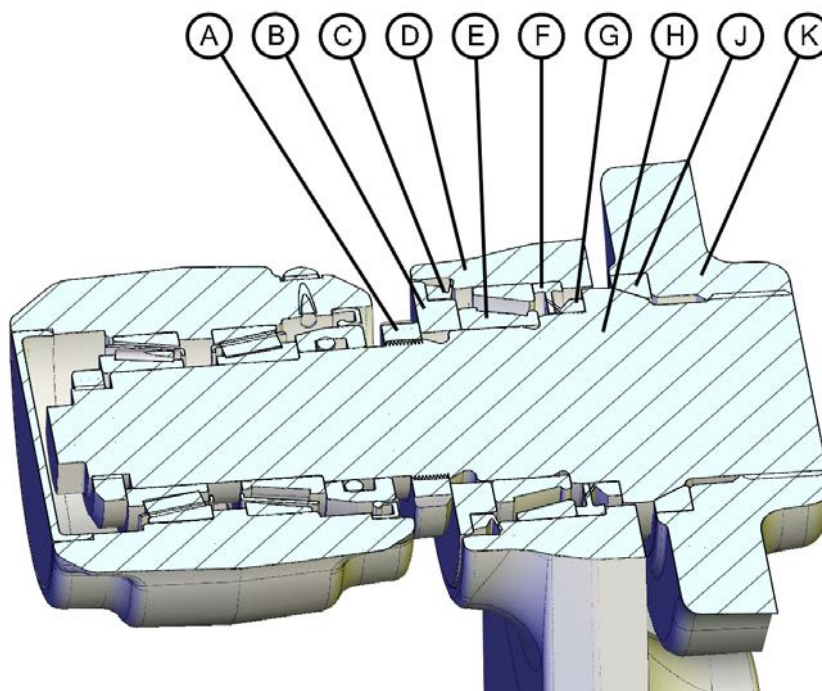

xx130000013

A	Lock nut
B	Support ring
C	Sealing ring (V-ring)
D	Lower arm
E	Bearing
F	T-ring
G	Sealing ring (V-ring)
H	Shaft
J	Bushing
K	Upper arm

Press tool, upper arm

The *press tool upper arm* is used to assemble T-ring and bearing in the upper arm.
For art. no. see [Required equipment on page 227](#).

Continues on next page

4 Repair

4.4.3 Replacing the upper arm

Continued

The same tool is used for removal and refitting but some parts are different. See figure!

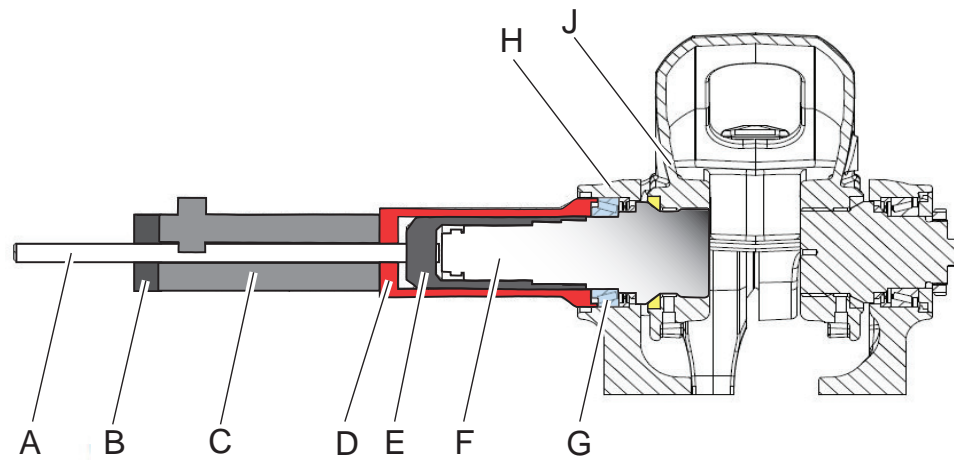

xx1100000269

- | | |
|----------|--|
| A | Threaded bar M16 |
| B | Thread washer (3HAC040021-004) |
| C | Hydraulic cylinder (3HAC040021-005) |
| D | Press bushing (3HAC040026-003). Only used at assembly. |
| E | Auxiliary shaft (3HAC040026-002) |
| F | Shaft |
| G | Bearing |
| H | Lower arm |
| J | Upper arm |

Continues on next page

Pull tool, shaft

The *pull tool shaft* is used to remove the shaft, bearing and T-ring in the upper arm. For art. no. see [Required equipment on page 227](#).

The *pull tool shaft* is using the same parts as the press tool upper arm but the press bushing is replaced by the *support bushing*. See part marked red in the figure.

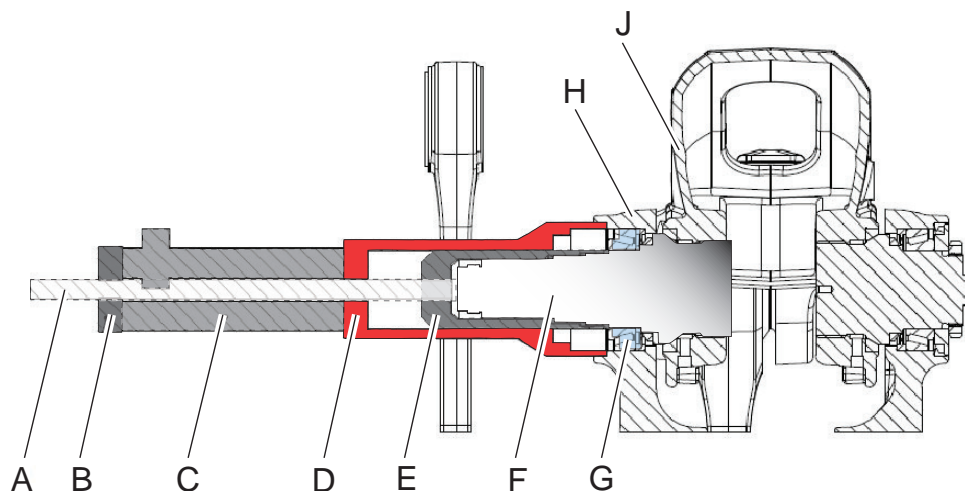

xx110000270

A	Threaded bar M16
B	Thread washer
C	Hydraulic cylinder
D	Support bushing (3HAC040026-004). Only used at removal.
E	Auxiliary shaft (3HAC040026-002)
F	Shaft
G	Bearing
H	Lower arm
J	Upper arm

Required equipment

Equipment, etc.	Art.no.	Note
Upper arm, axis 4	For spare part no. see: • Spare parts on page 403	Includes: • 3HAC037314-001 bushing (2 pcs)
V-ring	2216264-16	
T-ring	3HAC022581-001	
Adapter	3HAC040027-001	The adapter consists of two parts: the adapter and a protective cover. Always use the protective cover together with the adapter!
Press tool, support ring	3HAC072616-001	Used to press in new support rings in the upper arm housing, if damaged.

Continues on next page

4 Repair

4.4.3 Replacing the upper arm

Continued

Equipment, etc.	Art.no.	Note
Press tool, upper arm	3HAC040026-001	Including: <ul style="list-style-type: none"> • 3HAC040021-004 Thread washer • 3HAC040021-005 Hydraulic cylinder • 3HAC040026-003 Press bushing • 3HAC040026-002 Auxiliary shaft
Support, bushing	3HAC040026-004	When used with the parts from Press tool upper arm this tool is called <i>Pull tool, shaft</i> . The only difference is that the <i>press bushing</i> is replaced by the <i>support bushing</i> .
Socket, KM 12	3HAC040023-001	
Locking liquid	3HAB7116-1	Loctite 243
Bearing grease	3HAB3537-1	
Lubricant paste		Molycote 1000
Mounting/Demounting tool	3HAC040021-001	
Standard toolkit	-	Content is defined in section Standard tools on page 398 .
Other tools and procedures may be required. See references to these procedures in the step-by-step instructions below.		These procedures include references to the tools required.

Deciding calibration routine

Decide which calibration routine to be used, based on the information in the table. Depending on which routine is chosen, action might be required prior to beginning the repair work of the robot, see the table.



	Action	Note
1	Decide which calibration routine to use for calibrating the robot. <ul style="list-style-type: none"> • Reference calibration. External cable packages (DressPack) and tools can stay fitted on the robot. • Fine calibration. All external cable packages (DressPack) and tools must be removed from the robot. 	
	If the robot is to be calibrated with reference calibration: Find previous reference values for the axis or create new reference values. These values are to be used after the repair procedure is completed, for calibration of the robot. If no previous reference values exist, and no new reference values can be created, then reference calibration is not possible.	Follow the instructions given in the reference calibration routine on the FlexPendant to create reference values. Creating new values requires possibility to move the robot. Read more about reference calibration for Axis Calibration in Reference calibration routine on page 371 .

Continues on next page

Action	Note
<p>If the robot is to be calibrated with fine calibration:</p> <p>Remove all external cable packages (DressPack) and tools from the robot.</p>	

Preparations before removing the shafts of the upper arm

Use this procedure to do the necessary preparations before removing the upper arm.

Action	Note
1 Decide which calibration routine to use, and take actions accordingly prior to beginning the repair procedure.	
2 Remove all equipment fitted to upper arm and tilthouse unit.	
3 Jog axes 2 and 3 to the following positions: Axis 2: +40 degrees. Axis 3: -40 degrees.	
4  DANGER Turn off all: <ul style="list-style-type: none"> • electric power supply • hydraulic pressure supply • air pressure supply to the robot, before entering the robot working area.	
5 Remove the <i>cable harness</i> in the upper arm.	See section <ul style="list-style-type: none"> • Replacing the cable harness, upper end (incl. axis 6) on page 161
6  CAUTION The robot upper arm weighs 120 kg. All lifting accessories used must be sized accordingly!	
7 Secure the upper arm with a roundsling in an overhead crane or similar.	
8 Raise the lifting equipment to take the weight of the upper arm.	
9 Remove the <i>linkage system</i> .	See section <ul style="list-style-type: none"> • Replacing linkage - upper link arm on page 240 • Replacing linkage - lower link arm on page 248 • Replacing the linkage - link on page 255
10 Remove the <i>tilthouse unit</i> .	See section <ul style="list-style-type: none"> • Replacing the tilthouse unit on page 202

Continues on next page

4 Repair



4.4.3 Replacing the upper arm

Continued

	Action	Note
11	Remove the <i>parallel rod</i> .	For more information, see Replacing parallel rod on page 272 .

Removing the upper arm- part 1

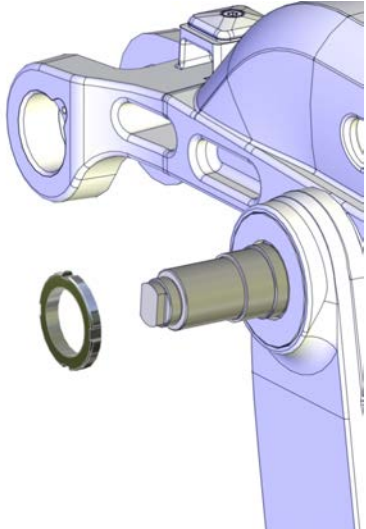
Use this procedure to remove the upper arm - part 1.

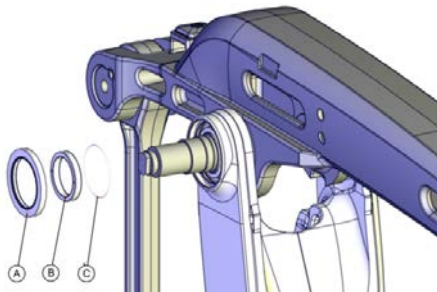
	Action	Note
1	<p>Remove the <i>lock nuts (KM12)</i> securing the shafts on axis 2 and axis 3 sides.</p> <p> Note</p> <p>Remove lock nuts on axis 2 and 3 sides!</p>	 <p>xx110000266</p>
2	<p>Remove the <i>Radial seal, sleeve and O-ring</i> from the shaft.</p> <p> Note</p> <p>Remove <i>Radial seal, sleeve and O-ring</i> on both axis 2 and 3 sides!</p>	 <p>xx110000267</p> <p>Parts:</p> <ul style="list-style-type: none">• A: Radial seal with dust lip• B: Sleeve• C: O-ring

Continues on next page

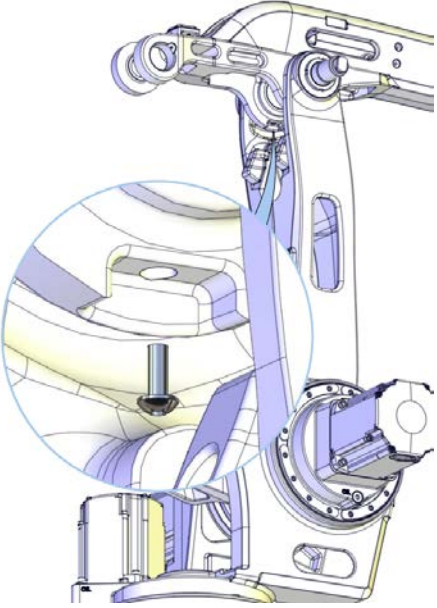
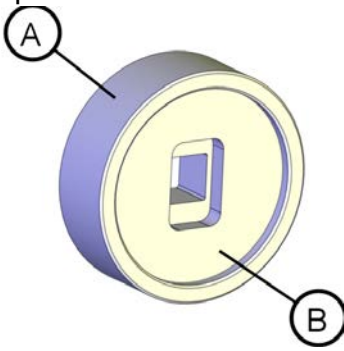
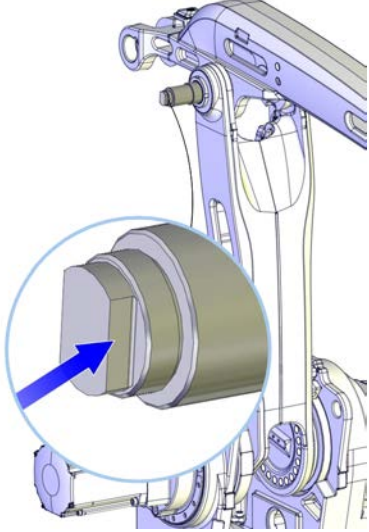
	Action	Note
3	<p>Remove the <i>set screws</i> securing the axis 2 and 3 shafts. One on each shaft.</p>	 <p>xx110000263</p>
4	<p>Place the <i>adapter</i> (including the protection cover) on the shaft.</p> <p>The adapter consists of two parts: the adapter and a protective cover. Always fit the protective cover to the adapter when using the adapter!</p>  <p>xx110000264</p> <ul style="list-style-type: none"> • A: Protective cover • B: Adapter 	 <p>xx110000265</p>

Removing the upper arm - part 2

Use this procedure to remove the upper arm - part 2.

	Action	Note
1	<p>Start the continued removal of shafts on the axis 3 side.</p>	
2	<p>NOTE!</p> <p>The axis 3 shaft must be removed in more than one step. The reason is the fitting of the outer race of the bearing is very tight.</p>	

Continues on next page

4 Repair

4.4.3 Replacing the upper arm

Continued



	Action	Note
3	Begin by carefully applying torque to release the shaft of axis 3. NOTE! Perform this move with care. Threads can otherwise be damaged.	
4	Continue releasing the shaft until the gap between the upper and lower arms on the axis 2 side has disappeared. NOTE! The shaft at this point still connects to the upper arm through the threads.	
5	Apply the <i>pull tool shaft</i> and pull the shaft with bearing and T-ring out, until the gap between upper and lower arms on the axis 3 side disappears.	TIP! Use a bar or similar to push the upper arm against the axis 3 side during the pulling out of the shaft. Insert the bar into the gap on the axis 2 side.
6	Remove the pull tool shaft and apply the adaptor on the shaft.	
7	Continue releasing the shaft from the upper arm using the adaptor. Release until the gap between lower and upper arms on the axis 2 side disappears again.	The upper arm will start to move against the axis 2 side again.
8	Check that the threads on the shaft and the upper arm are completely separated.	If the answer is "No", repeat the steps above to make sure the threads of the shaft and the upper arm are completely separated, before continuing.
9	If the answer is "Yes" pull the shaft out completely together with bearing and T-ring using the <i>pull tool shaft</i> .	
10	Put the shaft in a clean and safe place.	
11	 DANGER Before continuing check that the upper arm is secured in an overhead crane or similar. With axis 3 removed there will be no support for the upper arm.	
12	Remove the axis 2 shaft by following the steps above.	
13	Remove the <i>upper arm</i> .	
14	Check the V-ring! Replace if damaged!	

Preparations of the shafts before refitting the upper arm

Use this procedure to do the necessary preparations of shafts and bearings before refitting the upper arm.

	Action	Note
1	This procedure is best performed on a workbench or similar.	
2	Place the shafts on the workbench.	

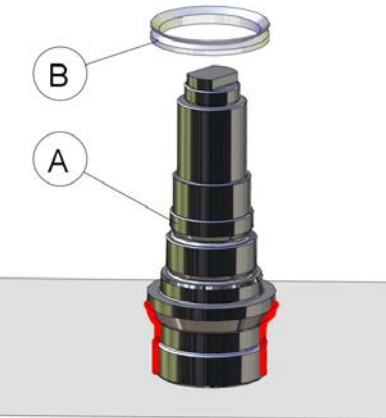
Continues on next page

	Action	Note
3	Fit the <i>sealing ring (V-ring)</i> on the shaft.	 <p>xx1100000268</p> <p>Parts:</p> <ul style="list-style-type: none"> • A: Shaft • B: Sealing ring (V-ring)
4	Apply some <i>grease</i> on shafts and sealing rings.	<p> Note</p> <p>Do not apply grease on threads and cones of the shafts. See area marked red in the figure above!</p>
5	Fill bearings with bearing grease.	<p> Note</p> <p>Rotate the bearing during filling grease to make sure the lubrication for both outer and inner races are good.</p>
6	Apply <i>lubricant paste (Molycote 1000)</i> on threads and cones of the shafts.	

Preparations before refitting the shafts of the upper arm

Use this procedure to do the necessary preparations before refitting the shafts.

	Action	Note
1	<p> CAUTION</p> <p>The robot upper arm weighs 120 kg. All lifting accessories used must be sized accordingly!</p>	
2	Secure the <i>upper arm</i> with a roundsling in an overhead crane or similar.	

Continues on next page



4 Repair

4.4.3 Replacing the upper arm

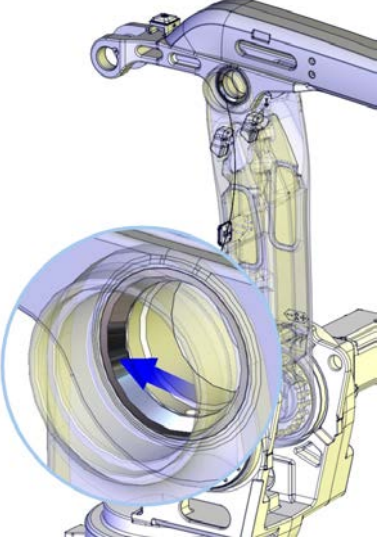
Continued

Action	Note
<p>3 Check that the <i>bushings</i> in the upper arm are without damages and still in the correct position.</p> <p> Note</p> <p>If damaged, replace the bushing!</p>	 <p>xx110000271</p>

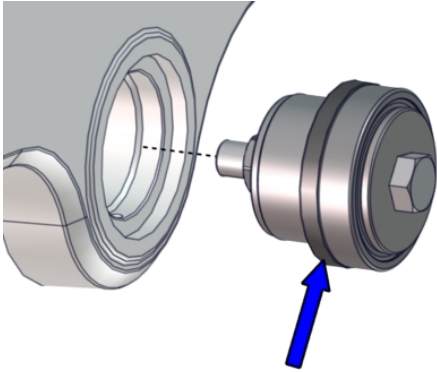
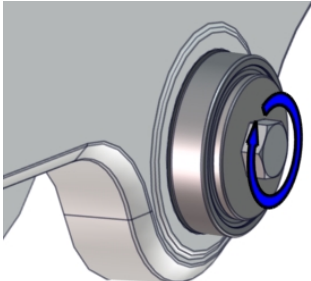
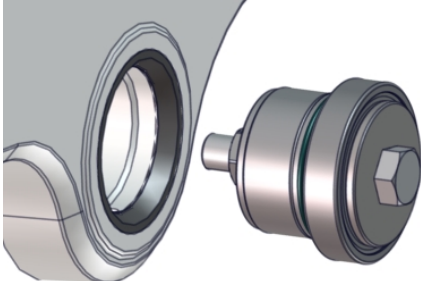
Continues on next page

Action	Note
<p>4 Valid for design with support rings. Check the support rings in the upper arm. If they are damaged, replace them accordingly:</p> <ol style="list-style-type: none"> 1 Fit a support ring to the <i>press tool</i> and lubricate with grease for easier assembly. 2 Press in the support ring to the upper arm housing by screwing on the press tool assembly. Tighten with 120 Nm. 3 Remove the press tool. The support ring is now fitted to the upper arm housing. 4 Repeat the procedure on the other side. <p> CAUTION</p> <p>If the support ring is mounted askew, there is a risk of play between the shaft and the upper arm. Make sure the support rings are aligned correctly (level) inside the upper arm housing.</p>	<p>Art. no. is specified Required equipment on page 227</p>  <p>xx1900001713</p>  <p>xx1900001714</p>  <p>xx1900001205</p>
<p>5 Move the <i>upper arm</i> to its mounting position. Make sure that the <i>upper arm</i> is placed in a horizontal position.</p>	<p> Note</p> <p>Make sure that the upper arm is placed correctly in a way that the shafts can be inserted without being damaged!</p>

Refitting the upper arm shafts

Use this procedure to refit the upper arm shafts.

Action	Note
<p>1 NOTE! Refit the shaft on the axis 3 side first!</p>	

Continues on next page



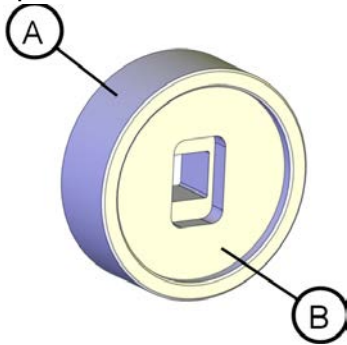
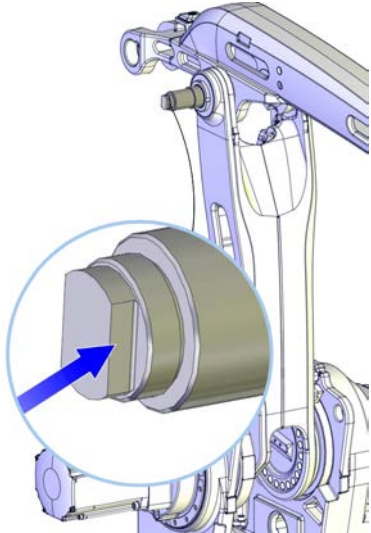
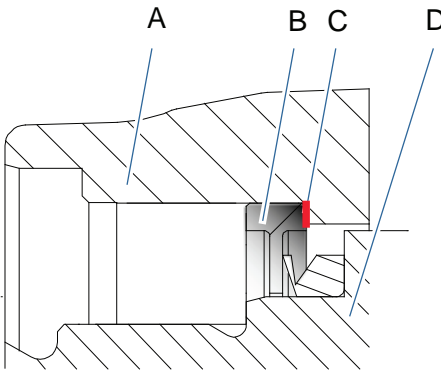

4 Repair

4.4.3 Replacing the upper arm

Continued

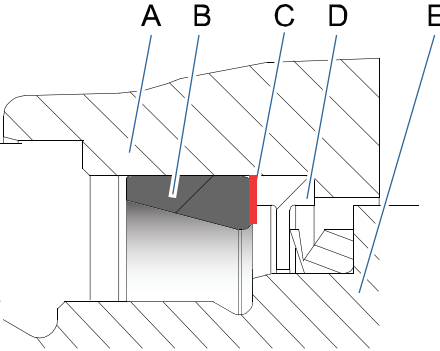
	Action	Note
2	<p>Carefully fit the <i>shaft</i> into the threads of the upper arm, by hand only.</p> <p> Note</p> <p>Do not use force since threads otherwise can be damaged!</p>	
3	<p>Place the <i>adapter</i> (including the protection cover) on the shaft.</p> <p>The adapter consists of two parts: the adapter and a protective cover. Always fit the protective cover to the adapter when using the adapter!</p>  <p>xx1100000264</p> <ul style="list-style-type: none"> • A: Protective cover • B: Adapter <p>Secure the shaft. Tightening torque: 800 Nm.</p>	 <p>xx1100000265</p>
4	<p>Place the <i>T-ring</i> on the shaft by hand as close to its final position as possible.</p>	 <p>xx1100000274</p> <p>Parts:</p> <ul style="list-style-type: none"> • A: Lower arm • B: T-ring • C: Surface on lower arm on which the T-ring rests against • D: Shaft

Continues on next page

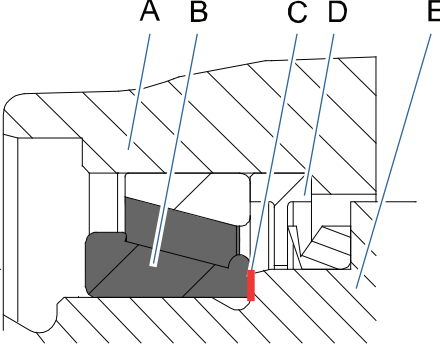
Action	Note
<p>5 Place the <i>outer race of the bearing</i> on the shaft as close to its final position as possible.</p>	 <p>xx110000276</p> <p>Parts:</p> <ul style="list-style-type: none"> • A: Lower arm • B: Outer bearing • C: Surface on T-ring on which outer race rests against • D: T-ring • E: Shaft
<p>6 Apply the press tool upper arm and press both parts into their final position.</p> <p> Note</p> <p>Make sure that the T-ring is pressed in all the way and rests against the lower arm correctly. See figure!</p> <p> Note</p> <p>Make sure the bearing is pressed in all the way and rests in the correct position on the shaft. See figure!</p>	<p>See the figures above!</p>
<p>7 Fill the inner race of the bearing with grease.</p>	
<p>8 Fit the <i>inner race of the bearing</i> on the shaft and press it in using the <i>press tool upper arm</i>.</p> <p> Note</p> <p>Make sure the bearing is pressed in all the way and rests in the correct position on the shaft. See figure!</p>	 <p>xx110000275</p> <p>Parts:</p> <ul style="list-style-type: none"> • A: Lower arm • B: Bearing inner race • C: Surface on shaft on which the inner race of bearing rests against • D: T-ring • E: Shaft

Continues on next page

4 Repair

4.4.3 Replacing the upper arm

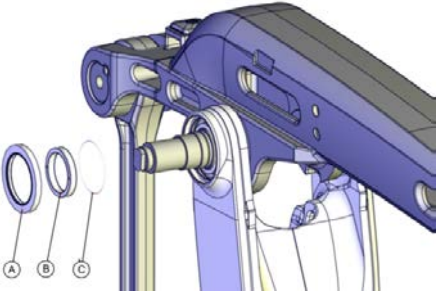

Continued

	Action	Note
9	Fit the <i>O-ring, Sleeve and Radial seal</i> .	 <p>xx1100000267</p> <p>Parts:</p> <ul style="list-style-type: none"> • A: Radial seal with dust lip • B: Sleeve • C: O-ring
10	<p>Only applicable to the axis 3 side!</p> <p>Secure the shaft with the lock nut on the axis 3 side by following this order:</p> <ol style="list-style-type: none"> 1 Apply locking liquid (Loctite 243) on the threads of the lock nut. 2 Tighten the lock nut with a tightening torque of 90 Nm. <p>NOTE!</p> <p>Notice the different procedures for axis 3 and axis 2 sides!</p>	
11	<p>Only applicable to the axis 2 side!</p> <p>Secure the shaft with the lock nut on the axis 2 side by following this order:</p> <ol style="list-style-type: none"> 1 Tighten the lock nut with a tightening torque of 200 Nm. Move the upper arm while applying the torque. 2 Unscrew the lock nut 3 Apply locking liquid (Loctite 243) on the threads of the lock nut. 4 Tighten the lock nut with a tightening torque of 90 Nm. Move the upper arm while applying the torque. <p>NOTE!</p> <p>Notice the different procedures for axis 3 and axis 2 sides!</p>	<p>NOTE!</p> <p>Moving the upper arm while tightening the lock nut is important for a correct fit!</p>
12	Refit the shaft on the axis 2 side, by following the steps in this procedure.	

Continues on next page

Refitting the upper arm - concluding procedures

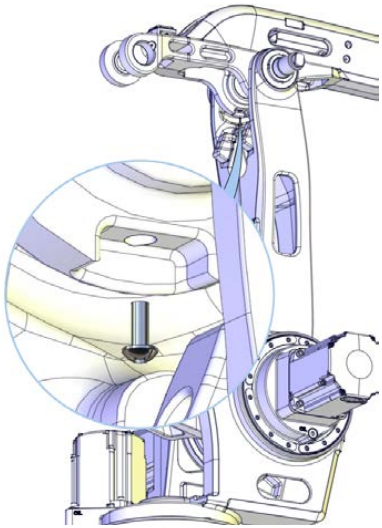
Use this procedure for the concluding refitting of the upper arm.

	Action	Note
1	Apply locking liquid (Loctite 243) in the two holes for the <i>set screws</i> and fit the screws.	 <p>xx1100000263</p> <p>Tightening torque: 34 Nm.</p>
2	Wipe residual grease and contamination off the shafts.	
3	Refit the <i>tilthouse unit</i> .	See Replacing the tilthouse unit on page 202 .
4	Refit the <i>parallel rod</i> .	See Replacing parallel rod on page 272 .
5	Refit the <i>cable harness</i> in the upper arm.	See section <ul style="list-style-type: none"> • Replacing the cable harness, upper end (incl. axis 6) on page 161
6	Refit the <i>linkage system</i> starting with the link.	Also see <ul style="list-style-type: none"> • Replacing linkage - upper link arm on page 240 • Replacing linkage - lower link arm on page 248 • Replacing the linkage - link on page 255
7	Recalibrate the robot.	Axis Calibration is described in Calibrating with Axis Calibration method on page 370 . General calibration information is included in section Calibration on page 359 .
8	 <p>DANGER</p> <p>Make sure all safety requirements are met when performing the first test run. See Test run after installation, maintenance, or repair on page 97.</p>	

4 Repair

4.4.4 Replacing linkage - upper link arm

4.4.4 Replacing linkage - upper link arm

Overview

The linkage consists of three basic parts - *upper link arm*, *lower link arm* and *link*. This procedure describes how to remove and refit the upper link arm.

How to replace lower link arm and link see:

- [Replacing linkage - lower link arm on page 248](#)
- [Replacing the linkage - link on page 255](#)

Location of upper link arm

The upper link arm is located as shown in the figure.

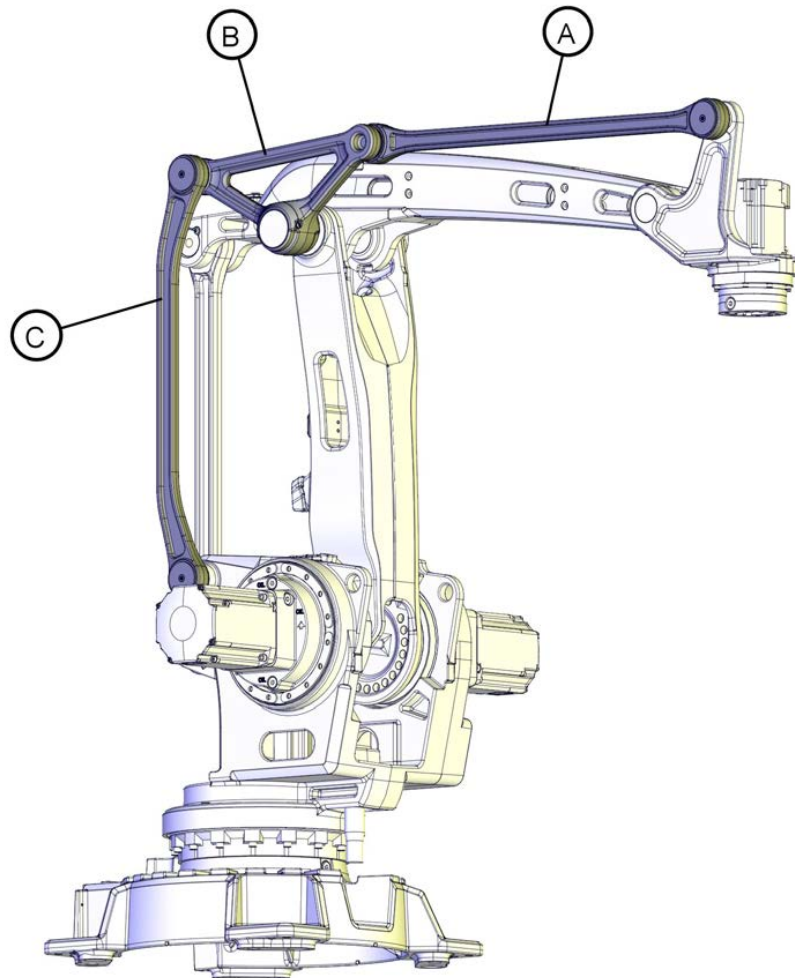

xx1100000167

- | | |
|----------|-----------------------|
| A | Upper link arm |
| B | Link |
| C | Lower link arm |

Continues on next page

Required equipment

Equipment	Art no.	Note
Upper link arm	For spare part no. see: • Spare parts on page 403	
Spherical roller bearing	For spare part no. see: • Spare parts on page 403	Replace if damaged. (2 pcs)
Bearing grease	3HAB3537-1	
Bearing puller		Bearing puller with three legs.
Locking liquid	3HAB7116-1	Loctite 243
Standard toolkit	-	Content is defined in section Standard tools on page 398 .
Other tools and procedures may be required. See references to these procedures in the step-by-step instructions below.		These procedures include references to the tools required.

Removing the upper link arm

Use this procedure to remove the upper link arm.

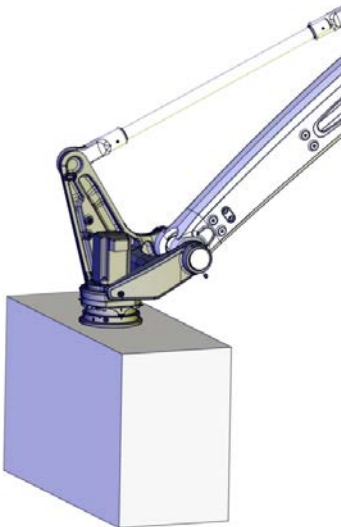

Action	Note
1 Put the robot in a position where it is possible to reach all parts that shall be removed.	Check especially that it is possible to remove the locking washer at the link.
2 Let the <i>tilthouse</i> rest on a workbench, on some pallets or similar. This is done in order to prevent the tilthouse from falling downwards when the upper link arm is removed.  CAUTION In order to avoid accidents, also secure the upper arm in an overhead crane.	 xx1000001132

Continues on next page

4 Repair

4.4.4 Replacing linkage - upper link arm

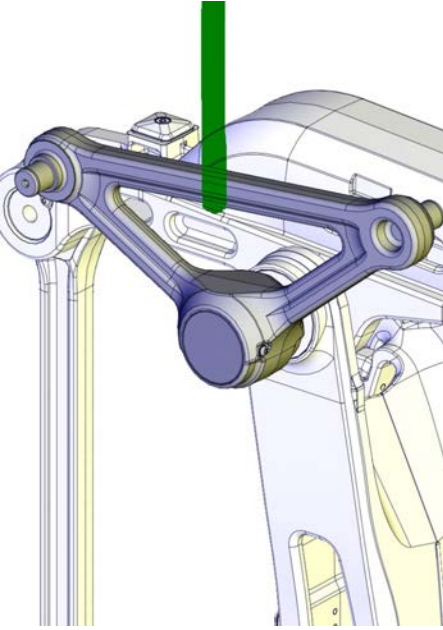
Continued

	Action	Note
3	<p> CAUTION</p> <p>If the lower link arm is removed, secure the <i>link</i> with a roundsling in an overhead crane. Use the hole in the middle of the link.</p> <p>This is done in order to prevent the link from moving if both the upper and lower link arms are removed.</p>	 <p>xx1100000173</p>
4	<p> DANGER</p> <p>Turn off all:</p> <ul style="list-style-type: none">• electric power supply• hydraulic pressure supply• air pressure supply <p>to the robot, before entering the robot working area.</p>	

Continues on next page

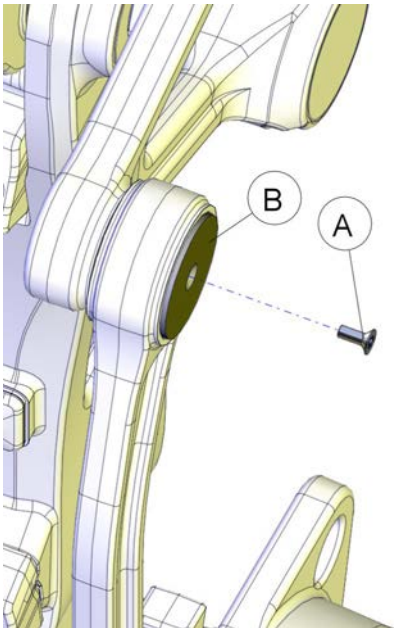
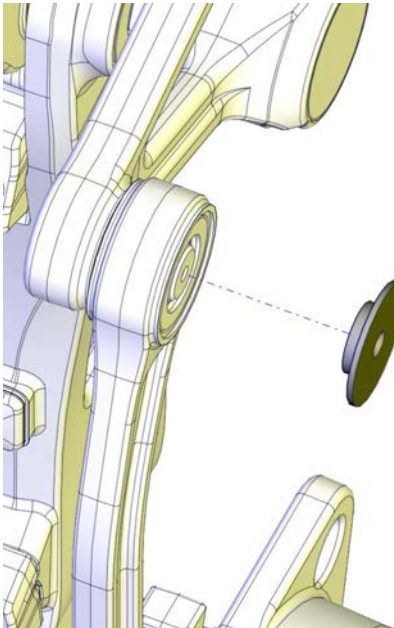
	Action	Note
5	Remove the <i>lock screw</i> securing the <i>locking washer</i> .	 <p>xx110000170</p> <p>Parts: A Lock screw B Locking washer</p>
6	Remove the <i>locking washer</i> .	 <p>xx110000171</p>

Continues on next page

4 Repair

4.4.4 Replacing linkage - upper link arm

Continued

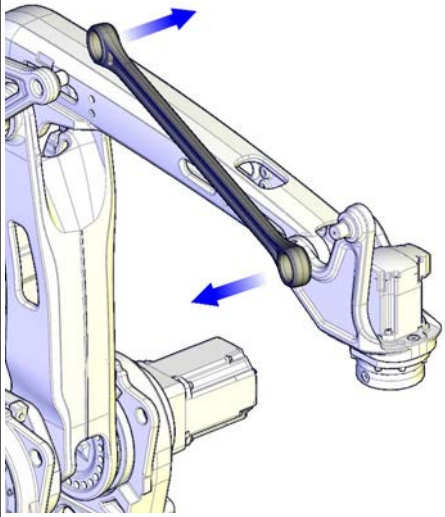
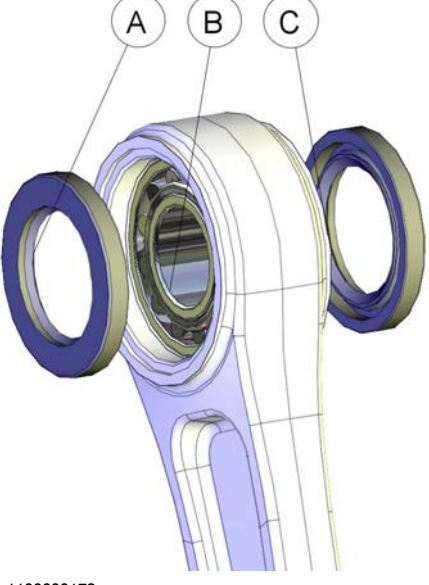
Action	Note
<p>7 Remove the <i>upper link arm</i> as shown in the figure.</p> <p>A three legged bearing puller will be needed to remove the link arm from the link. To remove it from the tilthouse a plastic mallet can be used.</p>	 <p>xx110000169</p>
<p>8 Remove the <i>radial sealing rings</i>.</p>	 <p>xx110000172</p> <p>Parts:</p> <ul style="list-style-type: none">A Radial sealing ringB BearingC Radial sealing ring
<p>9 Remove residual grease.</p>	

Continues on next page

Refitting the upper link arm

Use this procedure to refit the upper link arm.

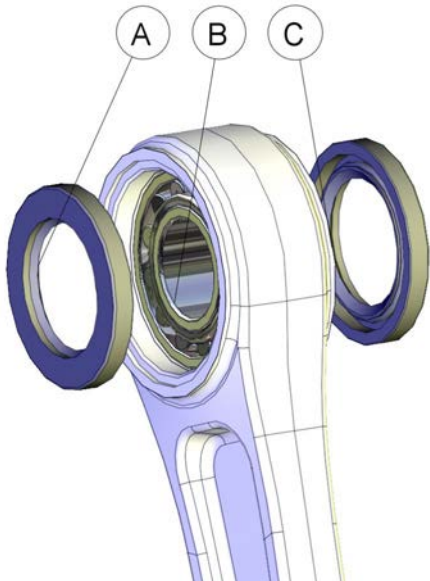

	Action	Note
1	If needed, replace the <i>bearings</i> in the upper link arm.  Note The bearings are sensitive for pushes. Make sure they are not damaged!	
2	Lubricate the bearings properly with <i>bearing grease</i> .	
3	Fit <i>radial sealing rings</i> in the upper link arm as shown in the figure.	 <p>xx110000172</p> <p>Parts: A Radial sealing ring B Bearing C Radial sealing ring</p>

Continues on next page

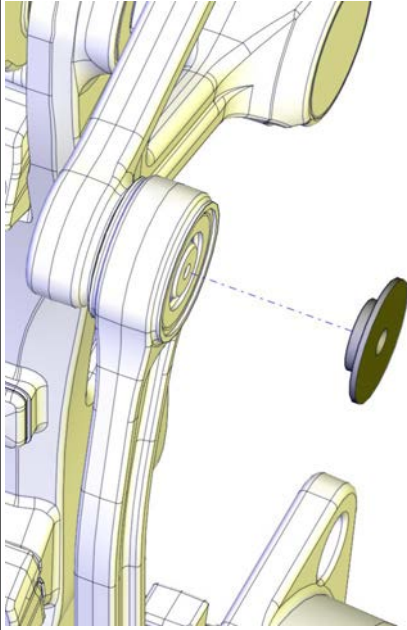

4 Repair

4.4.4 Replacing linkage - upper link arm

Continued

	Action	Note
4	Place the <i>locking washer</i> in the upper link arm.	 xx110000171
5	Apply a bearing puller with three legs and press the upper link arm on to the shaft.  Note The press force shall be applied on the locking washer.	Check that the upper link arm is pushed completely in position.
6	Apply <i>locking liquid</i> on the lock screw.	Loctite 243.

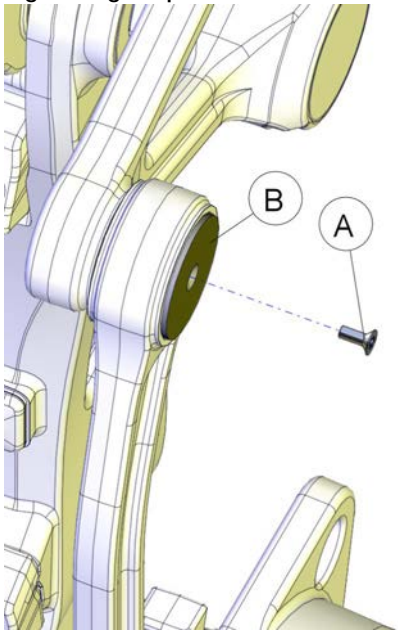
Continues on next page

	Action	Note
7	Secure the <i>locking washer</i> with the <i>lock screw</i> .	<p>Tightening torque: 25 Nm.</p>  <p>xx1100000170</p> <p>Parts: A Lock screw B Locking washer</p>
8	 <p>DANGER</p> <p>Make sure all safety requirements are met when performing the first test run. See Test run after installation, maintenance, or repair on page 97.</p>	

4 Repair

4.4.5 Replacing linkage - lower link arm

4.4.5 Replacing linkage - lower link arm

Overview

The linkage consists of three basic parts - *upper link arm*, *lower link arm* and *link*. This procedure describes how to remove and refit the lower link arm.

How to replace the upper link arm and link see:

- [Replacing linkage - upper link arm on page 240](#)
- [Replacing the linkage - link on page 255](#)

Location of lower link arm

The lower link arm is located as shown in the figure.

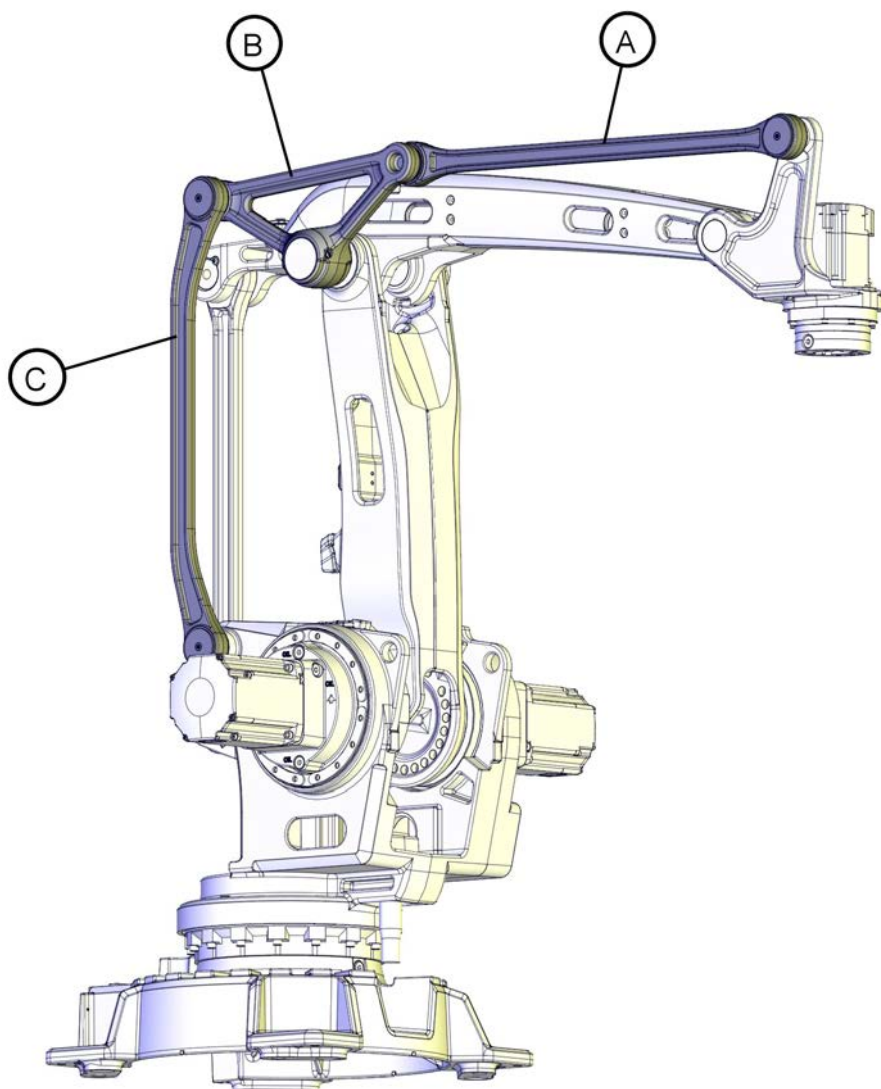

xx1100000167

- | | |
|----------|----------------|
| A | Upper link arm |
| B | Link |

Continues on next page

C Lower link arm

Required equipment

Equipment	Art no.	Note
Lower link arm	For spare part no. see: <ul style="list-style-type: none"> Spare parts on page 403 	
Spherical roller bearing	For spare part no. see: <ul style="list-style-type: none"> Spare parts on page 403 	Replace if damaged. 2 pcs
Bearing grease	3HAB3537-1	Tribol GR 100-2 PD
Bearing puller		Bearing puller with three legs.
Locking liquid	3HAB7116-1	Loctite 243
Standard toolkit		Content is defined in section Standard tools on page 398 .
Other tools and procedures may be required. See references to these procedures in the step-by-step instructions below.		These procedures include references to the tools required.

Removing the lower link arm

Use this procedure to remove the lower link arm.

Action	Note
1  DANGER Turn off all: <ul style="list-style-type: none"> electric power supply hydraulic pressure supply air pressure supply to the robot, before entering the robot working area.	

Continues on next page



4 Repair

4.4.5 Replacing linkage - lower link arm

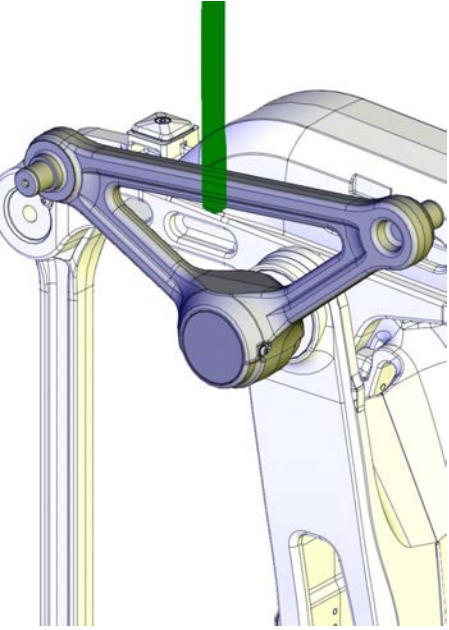
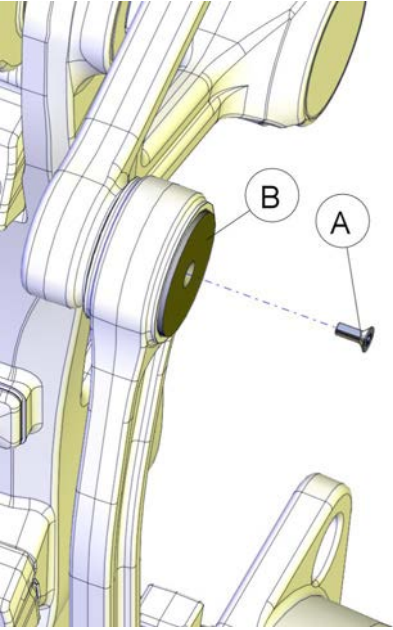
Continued

	Action	Note
2	<p> CAUTION</p> <p>If the upper link arm is removed, secure the <i>link</i> with a roundsling in an overhead crane. Use the hole in the middle of the link.</p> <p>This is done in order to prevent the link from moving if both the upper and lower link arms are removed.</p>	 <p>xx110000173</p>
3	<p>Remove the <i>lock screw</i> securing the locking washer.</p>	 <p>xx110000170</p> <p>Parts:</p> <ul style="list-style-type: none">A Lock screwB Locking washer

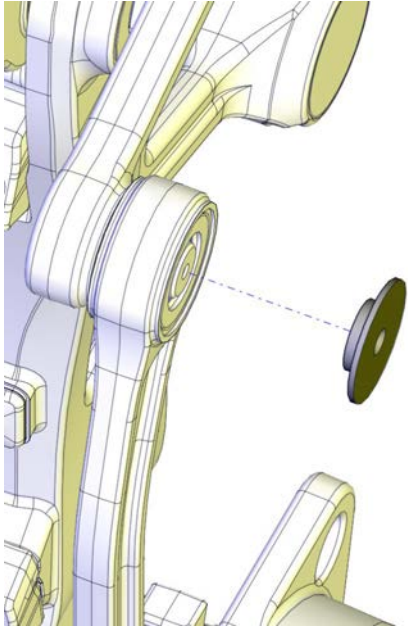
Continues on next page

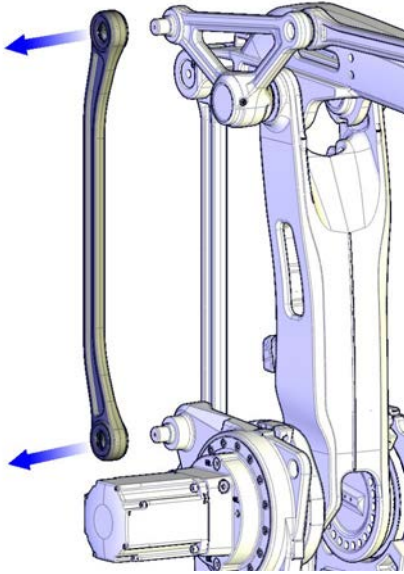
Action	Note
<p>4 Remove the <i>locking washer</i>.</p>	 <p>xx110000171</p>
<p>5 Remove the <i>lower link arm</i> by lifting it straight out.</p> <p>A three legged bearing puller will be needed to remove the link arm from the link. To remove it from the frame a plastic mallet can be used.</p> <p> Note</p> <p>If needed use a plastic mallet to remove the lower link arm.</p>	 <p>xx110000174</p>

Continues on next page

4 Repair

4.4.5 Replacing linkage - lower link arm

Continued

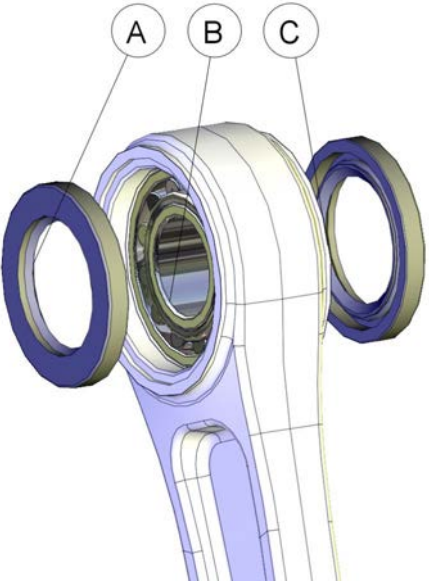

Action	Note
<p>6 Remove the <i>radial sealing rings</i>.</p>	 <p>xx110000172</p> <p>Parts:</p> <ul style="list-style-type: none"> A Radial sealing ring B Bearing C Radial sealing ring
<p>7 Remove residual <i>grease and sealing compound</i>.</p>	

Refitting the lower link arm

Use this procedure to refit the lower link arm.

Action	Note
<p>1 If needed, replace the <i>bearings</i>.</p> <p> Note</p> <p>The bearings are sensitive for pushes. Make sure they are not damaged!</p>	<p>Spare part no. is specified in Required equipment on page 249.</p>
<p>2 Lubricate the bearings properly with <i>bearing grease</i>.</p>	<p>For art. no. see Required equipment on page 249.</p>

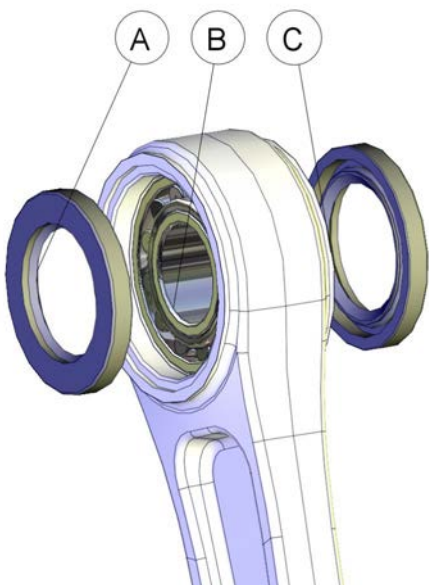
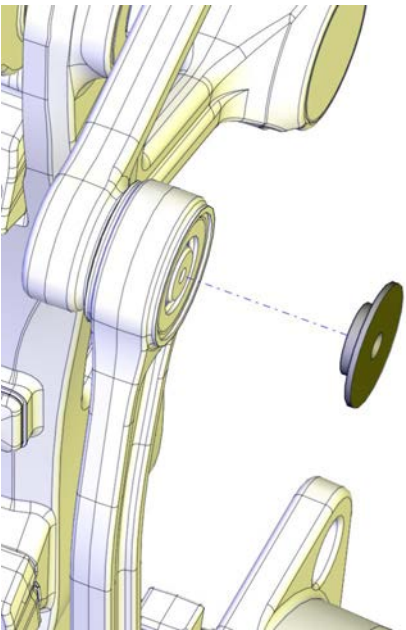
Continues on next page



Action	Note
<p>3 Fit the <i>radial sealing rings</i> in the lower link arm as shown in the figure.</p>	 <p>xx1100000172</p> <p>Parts:</p> <ul style="list-style-type: none"> A Radial sealing ring B Bearing C Radial sealing ring
<p>4 Place the <i>locking washer</i> in the lower link arm.</p>	 <p>xx1100000171</p>
<p>5 Apply a bearing puller with three legs and press the lower link arm on to the shaft.</p> <p> Note</p> <p>The press force shall be applied on the locking washer.</p>	<p>Check that the lower link arm is pushed completely in position.</p>

Continues on next page

4 Repair

4.4.5 Replacing linkage - lower link arm

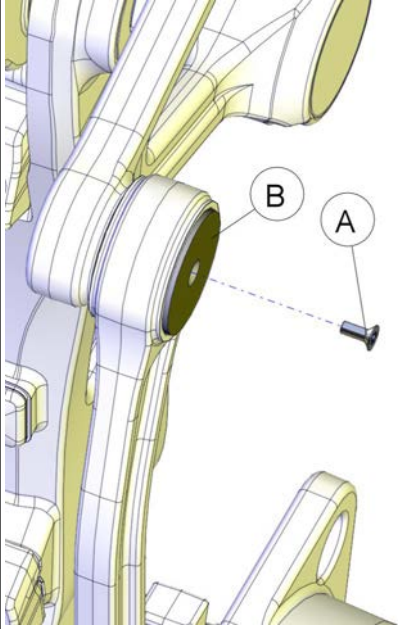
Continued

	Action	Note
6	Apply locking liquid on the lock screw.	Loctite 243
7	Secure the <i>locking washer</i> with the lock screw.	<p>Tightening torque: 25 Nm.</p>  <p>xx1100000170</p> <p>Parts:</p> <ul style="list-style-type: none">A Lock screwB Locking washer
8	<p> DANGER</p> <p>Make sure all safety requirements are met when performing the first test run. See Test run after installation, maintenance, or repair on page 97.</p>	

4.4.6 Replacing the linkage - link

Overview

The linkage consist of three basic parts - *upper link arm*, *lower link arm* and *link*. This procedure describes how to remove and refit the link.

How to replace the upper and lower link arms see:

- [Replacing linkage - upper link arm on page 240](#)
- [Replacing linkage - lower link arm on page 248](#)

Location of link

The link is located as shown in the figure.

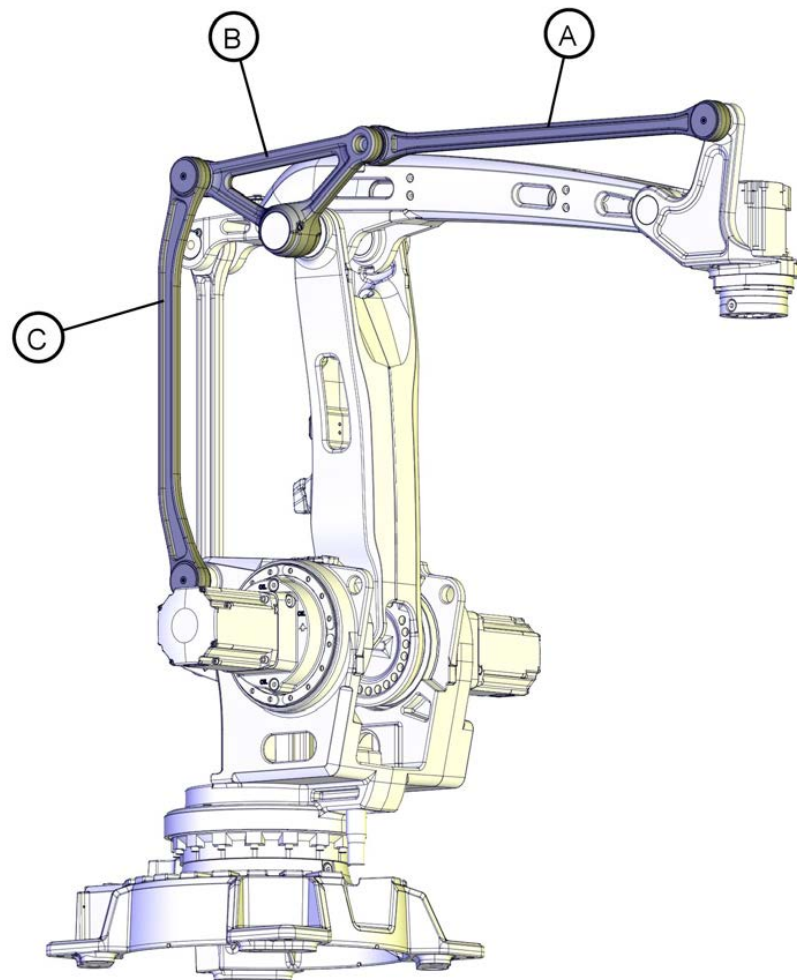

xx110000167

- | | |
|----------|-----------------------|
| A | Upper link arm |
| B | Link |
| C | Lower link arm |

Continues on next page

4 Repair

4.4.6 Replacing the linkage - link

Continued

Different versions of the sealing structure

Robots that are delivered from October 2012 and forward has a new sealing structure at the link that consists of a support ring, o-ring and radial sealing.

Robots delivered before October 2012 has a sealing structure that consists of a POM sealing, if not updated with the new sealing structure according to above.

The removal and refitting procedures describe both versions of sealing structures. The steps that differ are marked with information about which sealing structure the step is valid for.

X-ray view of the assembly of the link

The figure shows an X-ray view of the assembly of the link.

Design with POM sealing

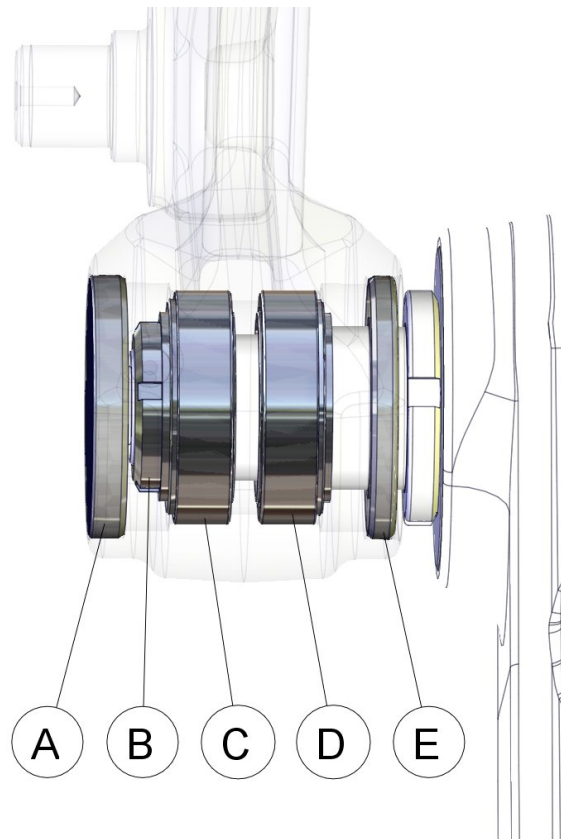

xx110000212

A	VK cover
B	Lock nut
C	Bearing
D	Bearing
E	POM Sealing

Continues on next page

Design with support ring

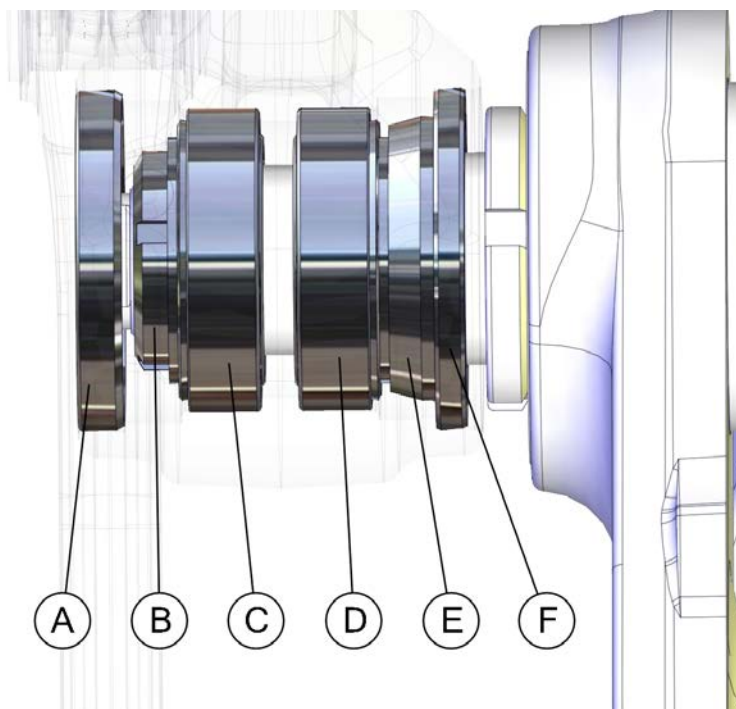

xx130000007

A	VK cover
B	Lock nut
C	Bearing
D	Bearing
E	Support ring, including o-ring
F	Radial sealing

Required equipment

Equipment, etc.	Art. no.	Note
Link	For spare part number, see: • Spare parts on page 403	
Bearing		Replace if damaged.
Radial sealing ⁱ		Replace if damaged.
Support ring ⁱ		Replace if damaged.
O-ring ⁱ		Replace if damaged.
Auxiliary shaft	3HAC040022-002	Used for bearings.
Press tool link (bearing outer races)	3HAC077981-001	Hydraulic pressing accessory used to press the outer races of the bearings in the link. User instructions are enclosed with the tool.
Press tool support	3HAC040031-001	
Press tool, link	3HAC040022-001	Used to fit the link.
Socket KM 8	3HAC040024-001	

Continues on next page

4 Repair

4.4.6 Replacing the linkage - link

Continued

Equipment, etc.	Art. no.	Note
Bearing puller	-	Used to remove the link.
Locking liquid	3HAB7116-1	Loctite 243
Locking liquid ⁱ	12340011-116	Loctite 574
Grease	3HAB3537-1	
Standard toolkit		Content is defined in section Standard tools on page 398 .
Other tools and procedures may be required. See references to these procedures in the step-by-step instructions below.		These procedures include references to the tools required.

ⁱ Valid for design with support ring.

Deciding calibration routine

Decide which calibration routine to be used, based on the information in the table. Depending on which routine is chosen, action might be required prior to beginning the repair work of the robot, see the table.



	Action	Note
1	Decide which calibration routine to use for calibrating the robot. <ul style="list-style-type: none"> Reference calibration. External cable packages (DressPack) and tools can stay fitted on the robot. Fine calibration. All external cable packages (DressPack) and tools must be removed from the robot. 	
	If the robot is to be calibrated with reference calibration: Find previous reference values for the axis or create new reference values. These values are to be used after the repair procedure is completed, for calibration of the robot. If no previous reference values exist, and no new reference values can be created, then reference calibration is not possible.	Follow the instructions given in the reference calibration routine on the FlexPendant to create reference values. Creating new values requires possibility to move the robot. Read more about reference calibration for Axis Calibration in Reference calibration routine on page 371 .
	If the robot is to be calibrated with fine calibration: Remove all external cable packages (DressPack) and tools from the robot.	

Removing the link

Use this procedure to remove the link.

	Action	Note
1	Decide which calibration routine to use, and take actions accordingly prior to beginning the repair procedure.	

Continues on next page

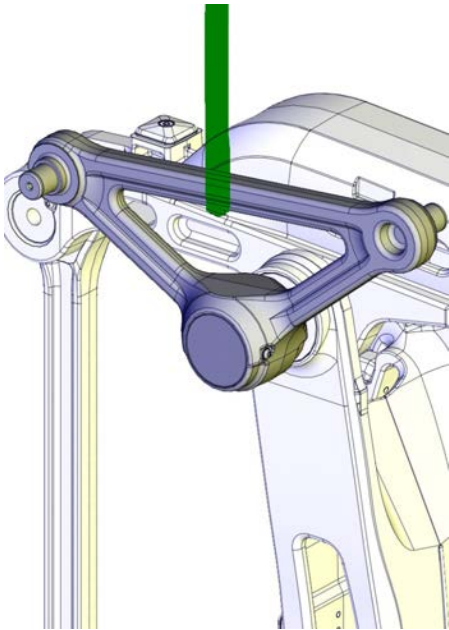

	Action	Note
2	<p> DANGER</p> <p>Turn off all:</p> <ul style="list-style-type: none"> • electric power supply • hydraulic pressure supply • air pressure supply <p>to the robot, before entering the robot working area.</p>	
3	<p>Secure the link with a <i>roundsling</i> in an overhead crane.</p> <p>Use the hole in the middle of the link.</p> <p> CAUTION</p> <p>This is done to prevent the link from moving when the upper and lower link arms are removed which can cause an accident.</p>	 <p>xx1100000173</p>
4	<p>Remove <i>upper</i> and <i>lower link arms</i>.</p>	<p>How to remove <i>upper</i> link arm see:</p> <ul style="list-style-type: none"> • Replacing linkage - upper link arm on page 240 <p>How to remove <i>lower</i> link arm see:</p> <ul style="list-style-type: none"> • Replacing linkage - lower link arm on page 248

Continues on next page

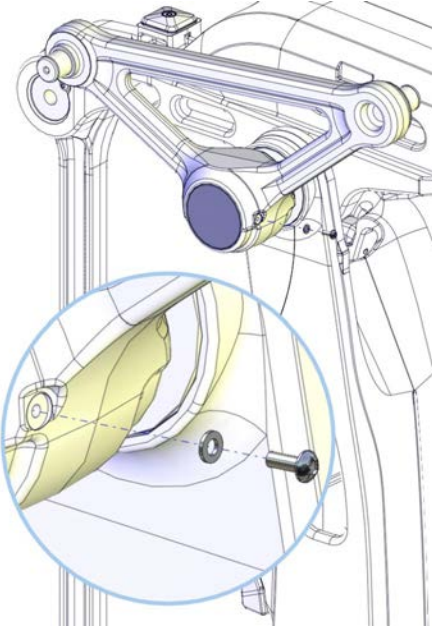

4 Repair

4.4.6 Replacing the linkage - link

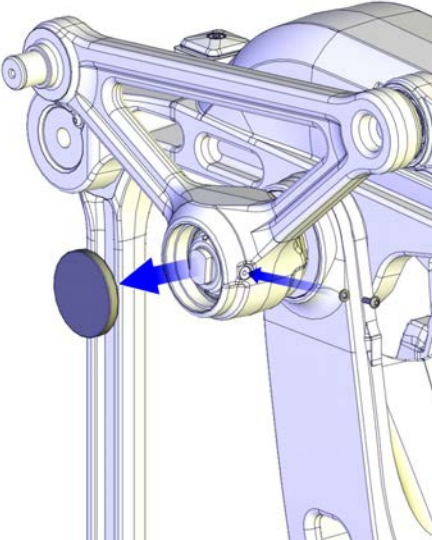
Continued

Action	Note
<p>5 Remove <i>screw and washer</i> in the hole for filling grease.</p>	 <p>xx110000196</p>
<p>6 Use <i>compressed air</i> to remove the VK cover. Blow with a very low air pressure into the hole for filling grease.</p> <p>Put one hand with some paper on top of the VK cover in order to catch it when it is released.</p> <p> CAUTION</p> <p>Only a very low air pressure is needed!</p>	 <p>xx110000195</p>

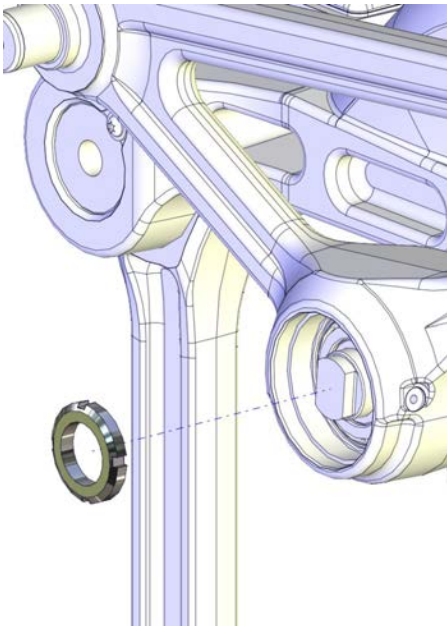
Continues on next page

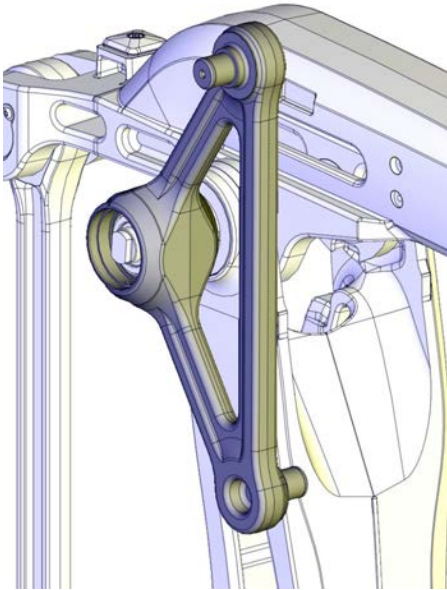
	Action	Note
7	Remove the <i>lock nut</i> (KM8).	 <p>xx1100000197</p>
8	Fit the <i>auxiliary shaft</i> on the shaft of the link.	
9	<p>Put the end of the link which is facing the upper rod, downwards in order to find room to knock on it with a plastic mallet from the inside. Knock on the link as close as possible to its center.</p> <p> Note</p> <p>Loosen the lifting force a little before start knocking. If not the link can be locked by the lifting power.</p>	<p>Normally a not too hard knock is needed to loosen the link. If needed use a bearing puller to remove the link.</p>  <p>xx1100000198</p>
10	Use a pair of levers or apply a <i>bearing puller</i> and bend the link loose.	
11	Remove the link.	

Continues on next page



4 Repair

4.4.6 Replacing the linkage - link

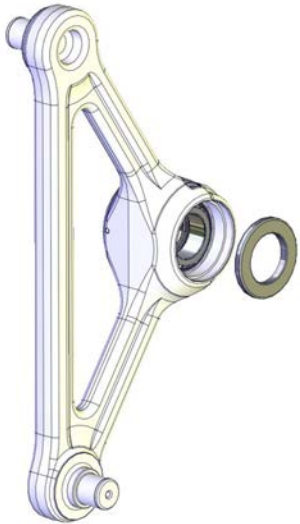
Continued

Action	Note
<p>12 Remove the <i>POM sealing</i> or the <i>support ring</i> (depending on version of sealing structure).</p>	 <p>xx1100000199</p>
<p>13 Wipe off residual grease.</p>	
<p>14 Valid for design with support ring. Remove the radial sealing from the link, if the link is to be replaced with a new spare part. Replace the radial sealing, if damaged.</p>	
<p>15 If needed, replace bearings.</p>	

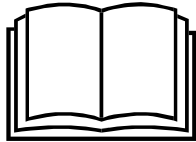
Fitting outer races of the bearings in link

Action	Note
<p>1 Put the <i>link</i> on a workbench.</p>	
<p>2 Fit the new <i>outer races</i> using the mounting tool.</p>  <p>xx0900000813</p> <p>Go to the user instructions enclosed with the press tool.</p> <p> DANGER</p> <p>Handling the tool incorrectly will cause serious injury. Read and follow enclosed user instructions for the tool.</p>	<p>Art. no. is specified in Required equipment on page 257</p>

Continues on next page

Refitting the link

Use this procedure to refit the link of the linkage.

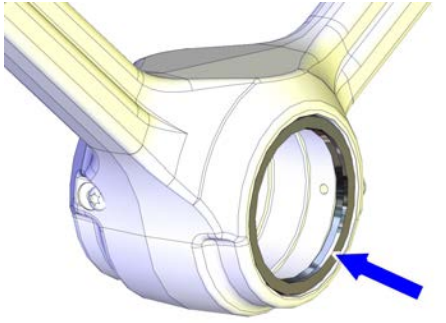
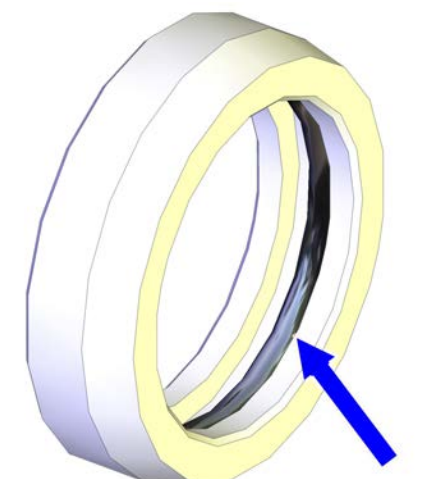
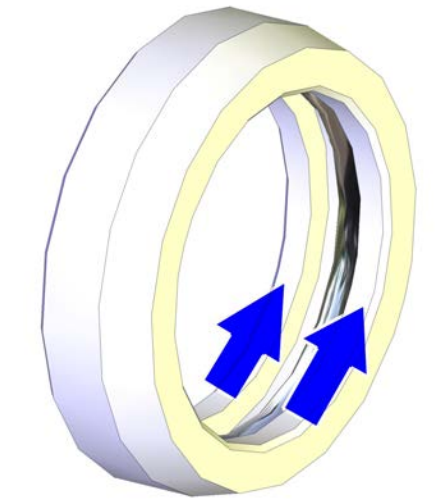
	Action	Note
1	<p>Valid for design with support ring. Place the radial sealing in the link.</p>	 <p>xx130000006</p>
2	<p>Valid for design with support ring. Place the o-ring inside the groove of the support ring.</p>	 <p>xx130000005</p>
3	<p>Valid for design with support ring. Apply locking liquid on the inner surface of the support ring.</p>	<p>Loctite 574</p>  <p>xx130000008</p>

Continues on next page

4 Repair

4.4.6 Replacing the linkage - link

Continued

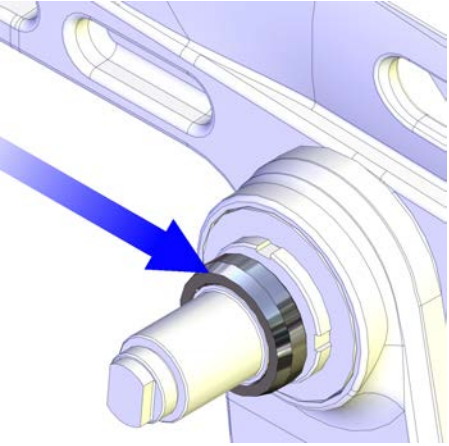
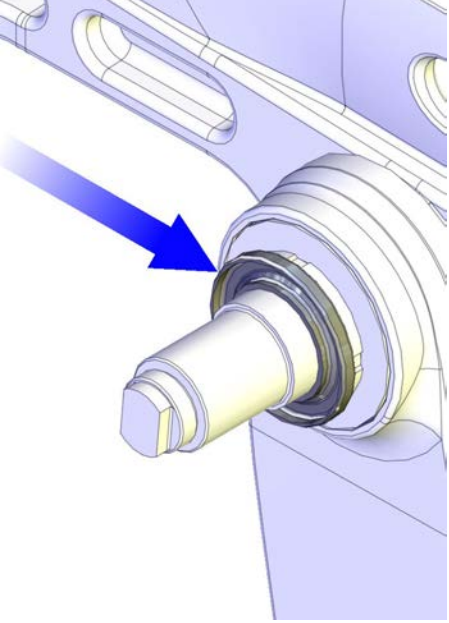
	Action	Note
4	<p>Valid for design with support ring. Fit the support ring with the included o-ring on the shaft. Use a plastic mallet, if necessary.</p> <p> Note</p> <p>Align the chamfer side of the support ring with the shaft shoulder as shown in figure.</p>	 <p>xx130000004</p>
5	<p>Valid for design with POM sealing. Place the <i>POM sealing</i> on the shaft.</p>	 <p>xx1100000200</p>
6	<p>Secure the link with a <i>roundsling</i> in an overhead crane and lift it to the mounting position.</p>	
7	<p>Fit the <i>auxiliary shaft</i> on the shaft.</p>	<p>Art.no. is specified in <i>Required equipment on page 257</i></p>

Continues on next page

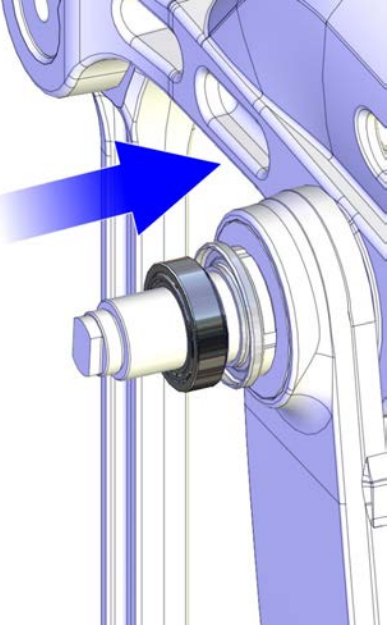
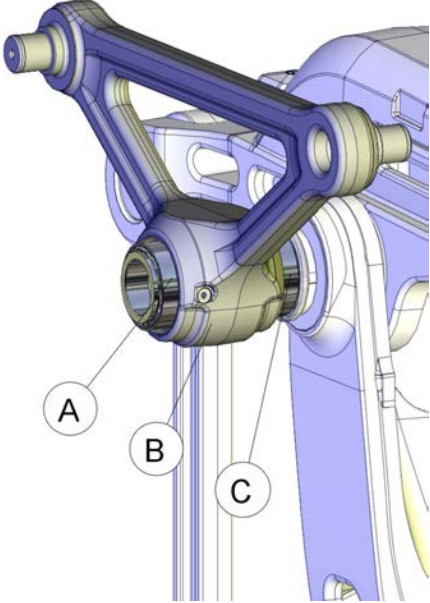

Action	Note
<p>8 Place the <i>inner race of the inner bearing</i> on the shaft and press it in position using the <i>press tool link</i>.</p>	<p>Art. no. is specified in <i>Required equipment on page 257</i>.</p>  <p>xx110000201</p> <p>Auxiliary shaft not shown in this figure.</p>
<p>9 Place the <i>inner race of the outer bearing and link</i>, in the following order on the shaft:</p> <ul style="list-style-type: none"> • link • bearing 	 <p>xx110000202</p> <p>Parts:</p> <ul style="list-style-type: none"> A: Inner race of outer bearing B: Link C: Inner bearing complete
<p>10 Press the parts together with the <i>press tool, link</i>.</p>	<p>Art.no. is specified in <i>Required equipment on page 257</i>.</p>

Continues on next page

4 Repair

4.4.6 Replacing the linkage - link

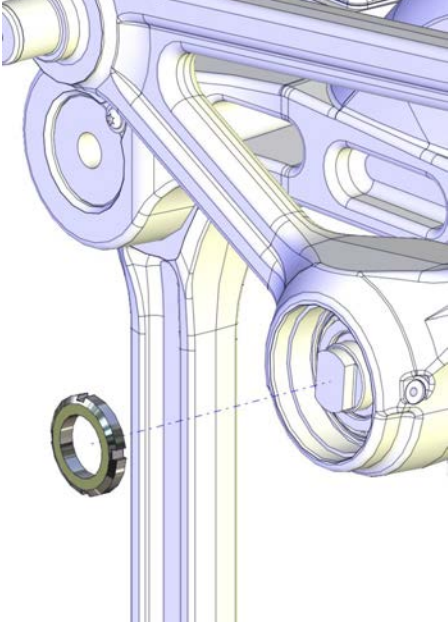
Continued

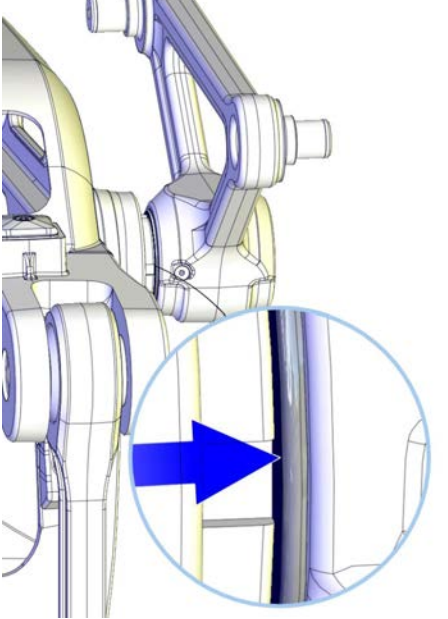
Action	Note
11 Apply <i>locking liquid</i> on the <i>lock nut</i> .	<p>Loctite 243</p>  <p>xx110000197</p>
12 Secure the lock nut in these three steps: 1 Tighten with a torque of 300 Nm, while rotating the link at the same time. 2 Unscrew the lock nut 3 Tighten the lock nut finally with a tightening torque of 90 Nm.	<p> Note</p> <p>The recommended order of tightening the lock nut is important to follow to avoid future problems with the shaft.</p>
13 Valid for design with POM sealing. Use a screwdriver carefully to fit the POM sealing into its final position.	 <p>xx110000204</p>

Continues on next page

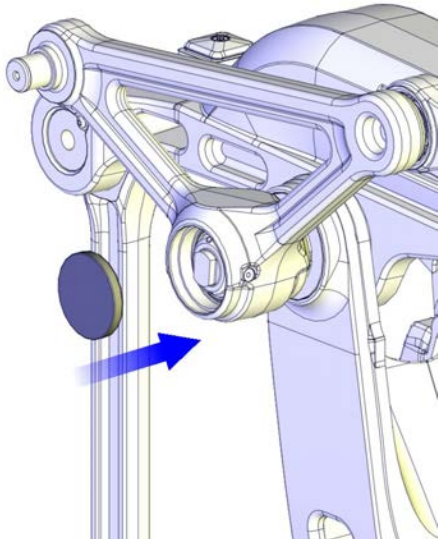
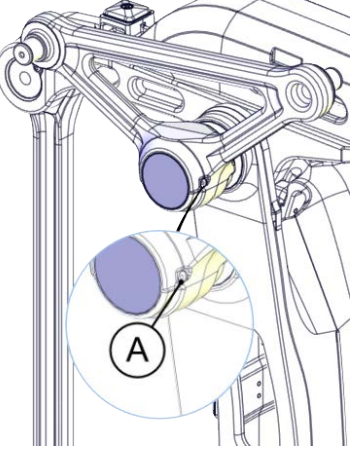
Action	Note		
<p>14 Refit the <i>VK cover</i>.</p>	 <p>xx110000205</p>		
<p>15 Make sure the vent hole is open.</p>	 <p>xx1900001001</p> <table border="1" data-bbox="989 1489 1428 1534"> <tr> <td data-bbox="989 1489 1029 1534">A</td> <td data-bbox="1029 1489 1428 1534">Vent hole</td> </tr> </table>	A	Vent hole
A	Vent hole		

Continues on next page

4 Repair

4.4.6 Replacing the linkage - link

Continued

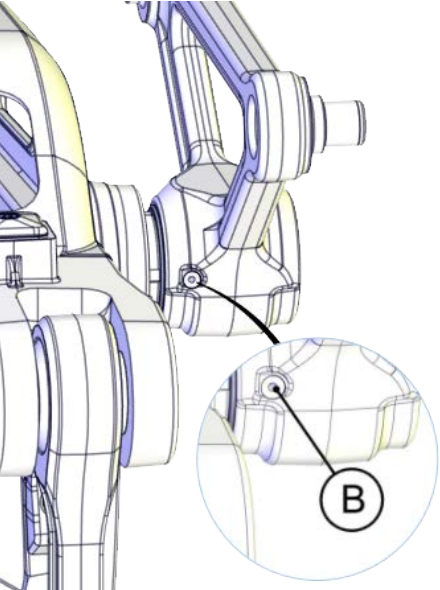
Action	Note		
16 Fill the link with <i>grease</i> .	<p data-bbox="960 315 1406 371">Art.no. is specified in Required equipment on page 257</p>  <p data-bbox="960 972 1066 987">xx190000923</p> <table border="1" data-bbox="960 1010 1401 1055"><tr><td data-bbox="960 1010 1007 1055">B</td><td data-bbox="1007 1010 1401 1055">Hole for filling grease</td></tr></table>	B	Hole for filling grease
B	Hole for filling grease		

Continues on next page

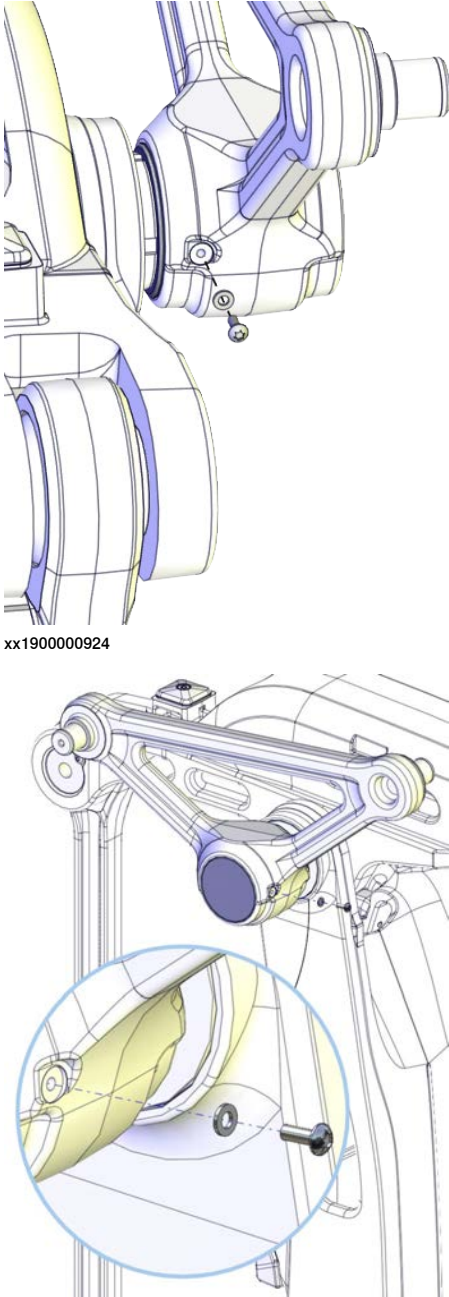
Action	Note
<p>17 Refit the <i>screw</i> and <i>washer</i> in the hole for filling grease and the vent hole.</p>	 <p>xx190000924</p> <p>xx110000196</p>
<p>18 Refit the <i>upper link arm</i>.</p>	<p>See section Replacing linkage - upper link arm on page 240</p>
<p>19 Refit the <i>lower link arm</i>.</p>	<p>See section Replacing linkage - lower link arm on page 248</p>
<p>20 Recalibrate the robot!</p>	<p>Axis Calibration is described in Calibrating with Axis Calibration method on page 370.</p> <p>General calibration information is included in section Calibration on page 359.</p>

Continues on next page

4 Repair

4.4.6 Replacing the linkage - link

Continued

	Action	Note
21	 DANGER Make sure all safety requirements are met when performing the first test run. See Test run after installation, maintenance, or repair on page 97 .	

4.4.7 Replacing the POM sealing for the link system

Overview

The linkage consist of three basic parts - *upper link arm*, *lower link arm* and *link*. How to replace the POM sealing is described in the same section as how to replace the link, see [Replacing the linkage - link on page 255](#).

X-ray view of the assembly of the link

The figure shows a X-ray view of the assembly of the link.

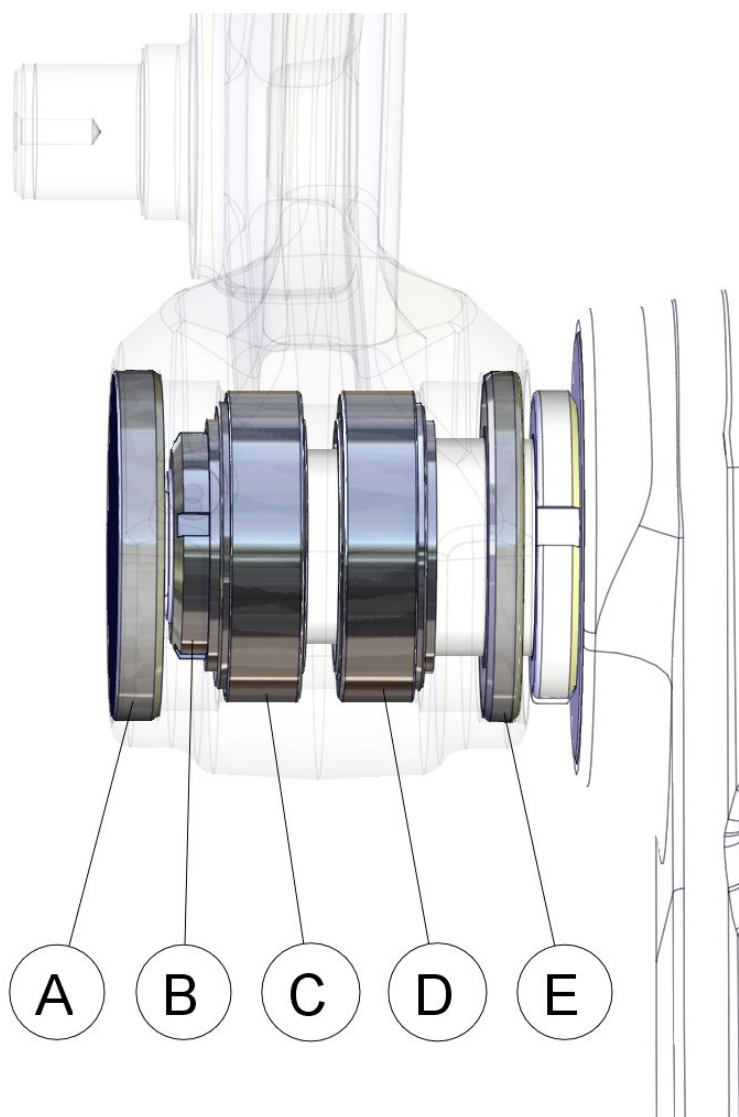

xx110000212

A	VK cover
B	Lock nut
C	Bearing
D	Bearing
E	POM Sealing

4 Repair

4.4.8 Replacing parallel rod

4.4.8 Replacing parallel rod

Location of the parallel rod

The parallel rod is located as shown in the figure.

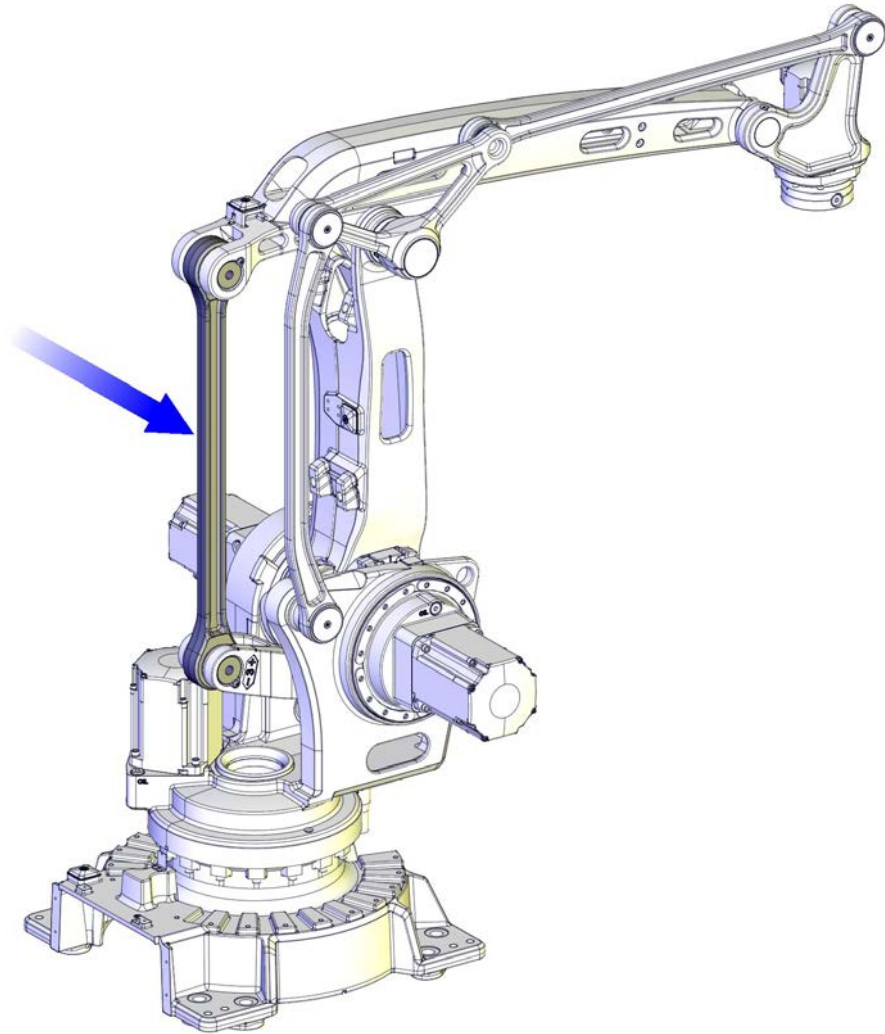

xx110000164

Required equipment

Equipment, etc.	Art.no.	Note
Parallel rod	For spare part no. see: <ul style="list-style-type: none">• Spare parts on page 403	
Mounting/Demounting tool	3HAC040021-001	
Locking liquid	3HAB7116-1	Loctite 243
Standard toolkit	-	Content is defined in section Standard tools on page 398 .

Continues on next page

Equipment, etc.	Art.no.	Note
Other tools and procedures may be required. See references to these procedures in the step-by-step instructions below.		These procedures include references to the tools required.

How to apply the mounting/demounting tool for removal

This figure shows how to apply the mounting/demounting tool when removing the parallel rod. For art. no. see [Required equipment](#).

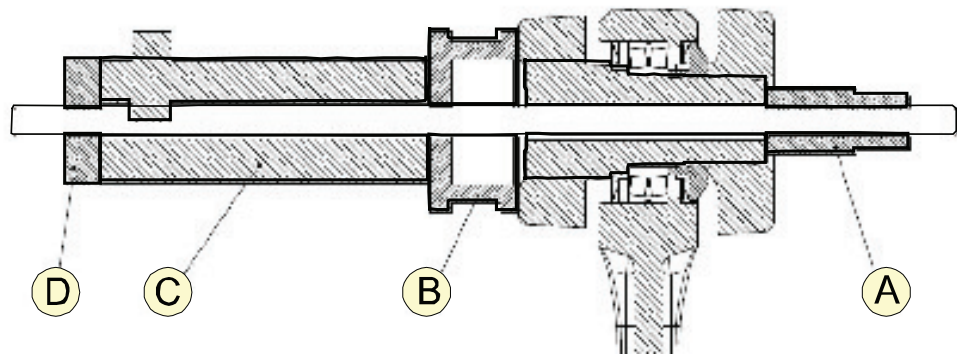



xx1100000166

- A Thread bush
- B Support bush
- C Hydraulic cylinder
- D Thread washer

Removing the parallel rod

Use this procedure to remove the parallel rod. The procedure is the same in both ends.

	Action	Note
1	 DANGER Turn off all: <ul style="list-style-type: none"> • electric power supply • hydraulic pressure supply • air pressure supply to the robot, before entering the robot working area.	
2	 CAUTION In order to avoid accidents secure the upper arm with a <i>roundsling</i> in an overhead crane or similar.	

Continues on next page

4 Repair

4.4.8 Replacing parallel rod

Continued

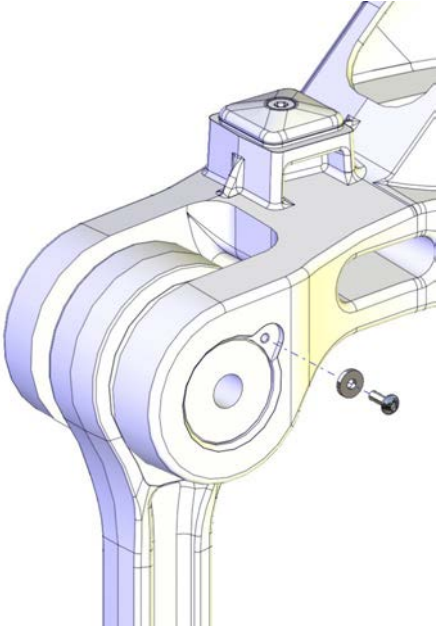
	Action	Note
3	Remove the <i>lock screw</i> and <i>washer</i> , securing the shaft of the parallel rod in position.	 <p>xx110000141</p>

Continues on next page

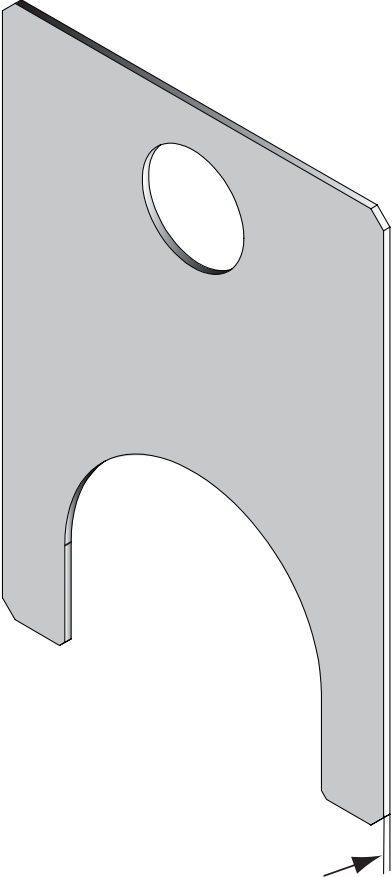
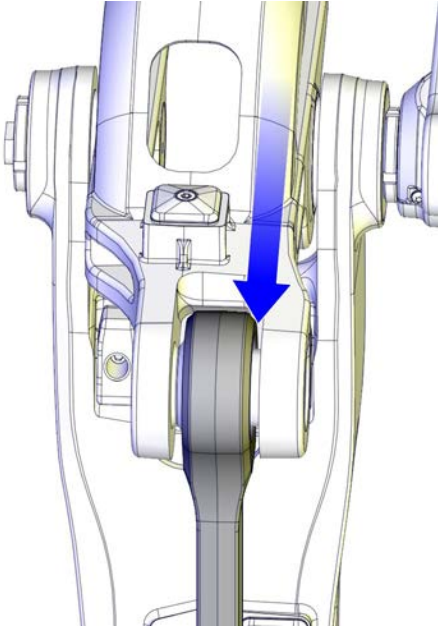

Action	Note
<p>4 Apply a <i>shims</i> (T= 8 mm) on axis 3 side, as shown in the figure to the right.</p>  <p>xx1100000030</p> <p>A: Thickness = 8 mm.</p>	 <p>xx1100000142</p>
<p>5 Apply the <i>mounting/demounting</i> tool to the shaft.</p>	<p>For art. no. see:</p> <ul style="list-style-type: none"> • Required equipment on page 272

Continues on next page

4 Repair

4.4.8 Replacing parallel rod

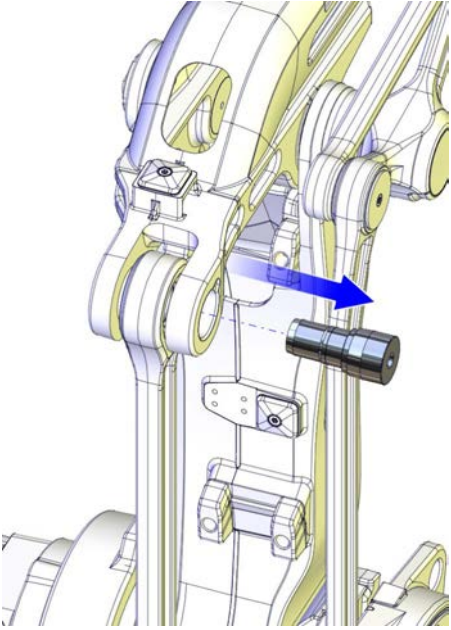
Continued

Action	Note
6 Remove the upper <i>shaft</i> .	 <p>xx110000144</p>
7 Move the <i>parallel rod</i> backwards from its upper connection point and let it rest against the base.	 <p>xx110000146</p>

Continues on next page

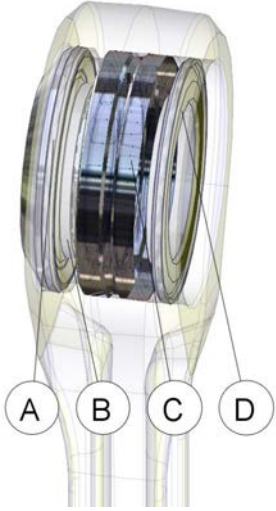
	Action	Note
8	Remove the <i>thrust washer</i> with a <i>POM sealing</i> fitted on the axis 2 side.	 <p data-bbox="986 943 1098 965">xx110000145</p> <p data-bbox="986 981 1054 1003">Parts:</p> <ul data-bbox="1023 1010 1406 1160" style="list-style-type: none"> • A: Thrust washer • B: Bearing • C: POM sealing fitted on thrust washer (axis 2 side) • D: POM sealing (axis 3 side)
9	Remove the <i>POM sealing</i> on the axis 3 side.	See figure above!
10	Remove the <i>lower end</i> of the parallel rod in the same way as the upper end	
11	Remove the parallel rod from the robot.	
12	Replace the <i>bearings</i> , if necessary.	

How to apply the mounting/demounting tool for refitting

This figure shows how to apply the mounting/demounting tool when refitting the parallel rod. For art. no. see [Required equipment](#).

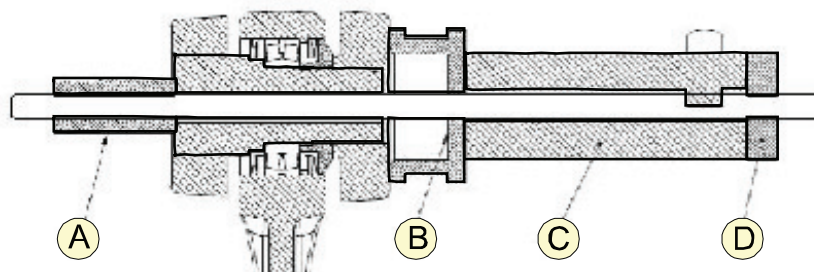

xx110000165

- A Thread bush
- B Support bush
- C Hydraulic cylinder

Continues on next page

4 Repair

4.4.8 Replacing parallel rod

Continued

D Tread washer

Refitting the parallel rod

Use this procedure to refit the parallel rod. The procedure is the same in both ends.

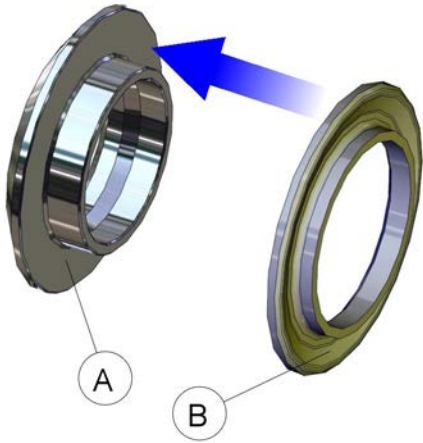
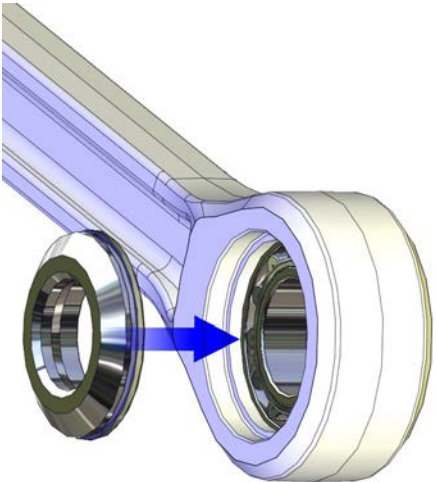
	Action	Note
1	Start refitting the lower end of the parallel rod.	
2	Make sure the bearings are in the correct position in the parallel rod.	
3	Fit a <i>POM sealing</i> on the <i>thrust washer</i> .	 <p data-bbox="957 1240 1066 1261">xx110000148</p> <ul data-bbox="991 1279 1222 1339" style="list-style-type: none">• A: Thrust washer• B: POM sealing
4	Put the <i>thrust washer</i> (with a POM sealing fitted) on the axis 2 side of the parallel rod.	 <p data-bbox="957 1989 1066 2009">xx110000149</p>

Continues on next page

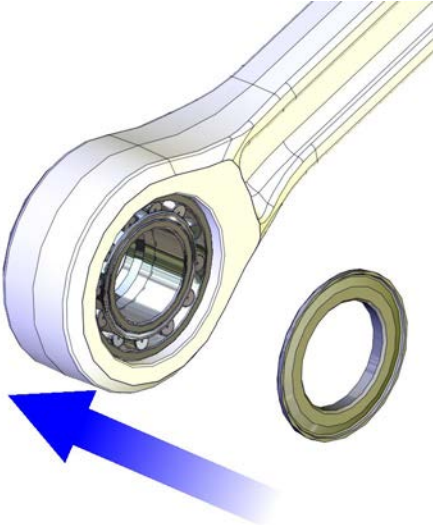
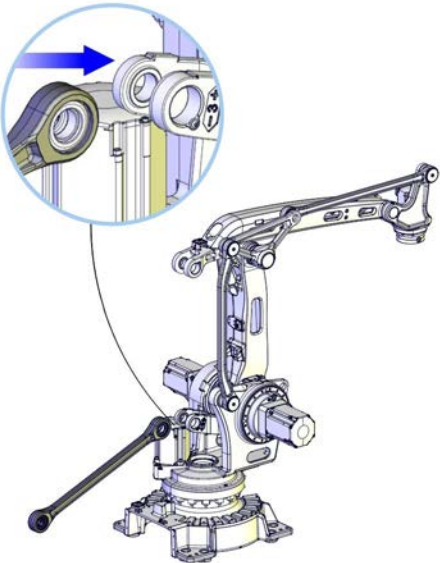
	Action	Note
5	Place the other <i>POM sealing</i> on the axis 3 side.	 <p>xx1100000151</p>
6	Place the parallel rod in its mounting position in the lower end.	 <p>xx1100000161</p>

Continues on next page

4 Repair

4.4.8 Replacing parallel rod

Continued

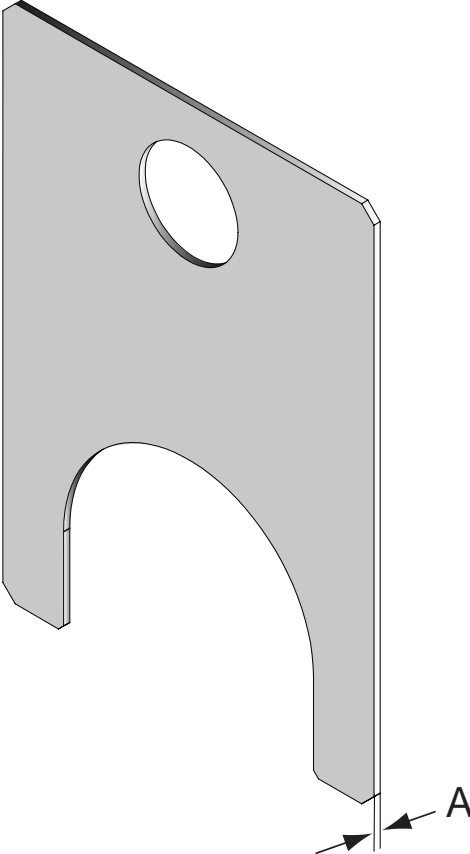
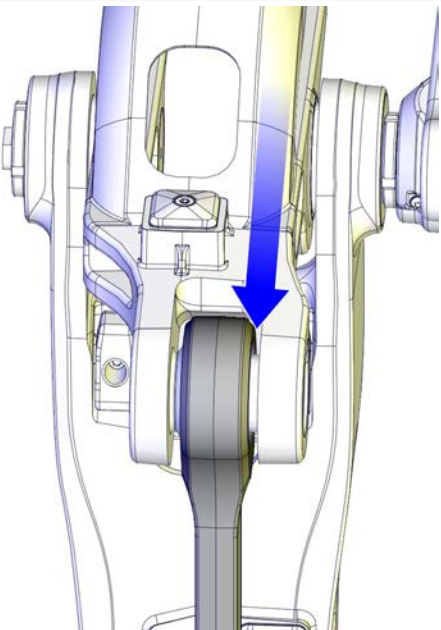
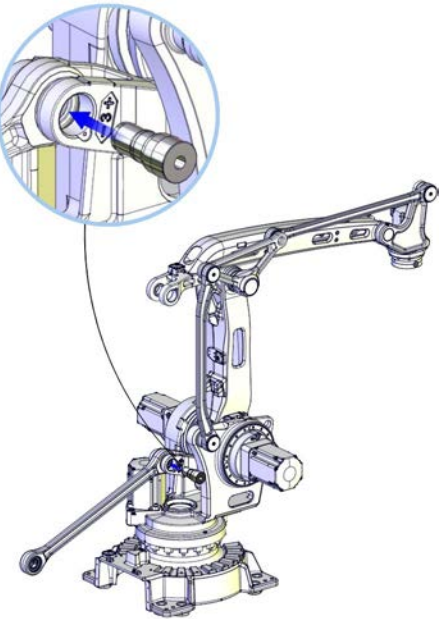
	Action	Note
7	<p>Apply a <i>shims</i> (T= 8 mm) on the axis 3 side, as shown in the figure to the right. Do not press the shims down too far.</p>  <p>xx110000030</p> <p>A = Thickness 8 mm</p>	 <p>xx110000142</p>
8	<p>Refit the <i>shaft</i> using the <i>mounting/demounting tool</i>.</p>	 <p>xx110000162</p>

Continues on next page

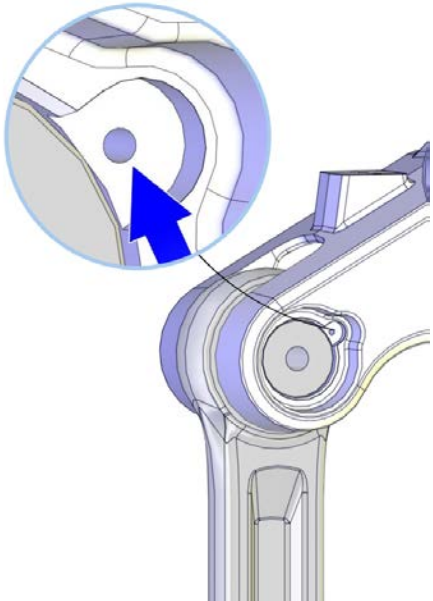
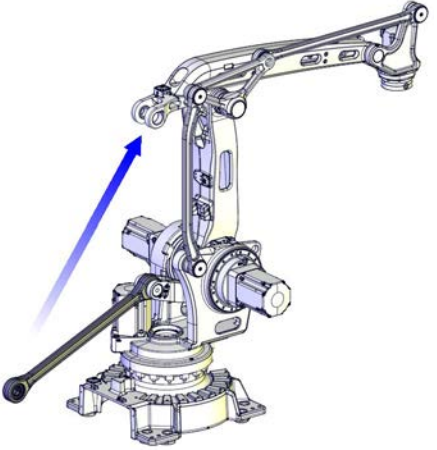
	Action	Note
9	Apply <i>locking liquid</i> in the hole of the lock screw.	<p>Loctite 243</p>  <p>xx1000001349</p>
10	Refit the <i>lock screw</i> and plain washer.	<p>Lock screw: M6x 16 Plain washer: 6.4x12x1.6</p>
11	Lift the parallel rod up into position for fitting of the upper end.	 <p>xx1100000163</p>
12	Refit the <i>upper end</i> of the parallel rod in the same way.	

Continues on next page

4 Repair

4.4.8 Replacing parallel rod

Continued

	Action	Note
13	 DANGER Make sure all safety requirements are met when performing the first test run. See Test run after installation, maintenance, or repair on page 97 .	

4.4.9 Replacing the complete lower arm system

Location of lower arm system

The complete lower arm system consist of *lower arm* and *parallel arm*. The lower arm system is located as shown in the figure.

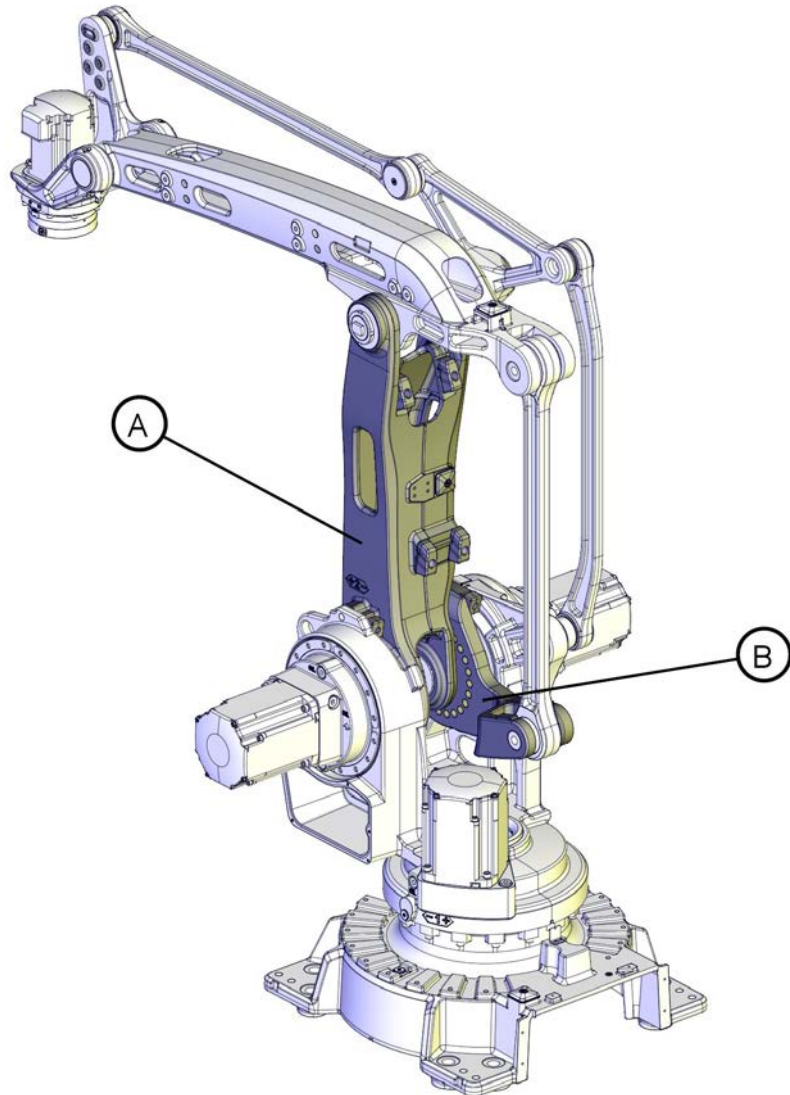

xx110000175

- A** Lower arm
B Parallel arm

Required equipment

Equipment, etc.	Art.no.	Note
Lower arm	For art. no. see: <ul style="list-style-type: none"> Spare parts on page 403 	
Lock screw	-	M16x90

Continues on next page

4 Repair

4.4.9 Replacing the complete lower arm system

Continued

Equipment, etc.	Art.no.	Note
Rotation tool		
Mounting/Demounting tool	3HAC040021-001	
Standard toolkit	-	Content is defined in section Standard tools on page 398 .
Other tools and procedures may be required. See references to these procedures in the step-by-step instructions below.		These procedures include references to the tools required.
Circuit diagram		See Circuit diagrams on page 405 .

Deciding calibration routine

Decide which calibration routine to be used, based on the information in the table. Depending on which routine is chosen, action might be required prior to beginning the repair work of the robot, see the table.

	Action	Note
1	Decide which calibration routine to use for calibrating the robot. <ul style="list-style-type: none">Reference calibration. External cable packages (DressPack) and tools can stay fitted on the robot.Fine calibration. All external cable packages (DressPack) and tools must be removed from the robot.	
	If the robot is to be calibrated with reference calibration: Find previous reference values for the axis or create new reference values. These values are to be used after the repair procedure is completed, for calibration of the robot. If no previous reference values exist, and no new reference values can be created, then reference calibration is not possible.	Follow the instructions given in the reference calibration routine on the FlexPendant to create reference values. Creating new values requires possibility to move the robot. Read more about reference calibration for Axis Calibration in Reference calibration routine on page 371 .
	If the robot is to be calibrated with fine calibration: Remove all external cable packages (DressPack) and tools from the robot.	

Removing the lower arm system

Use this procedure to remove the lower arm system.

	Action	Note
1	Decide which calibration routine to use, and take actions accordingly prior to beginning the repair procedure.	

Continues on next page

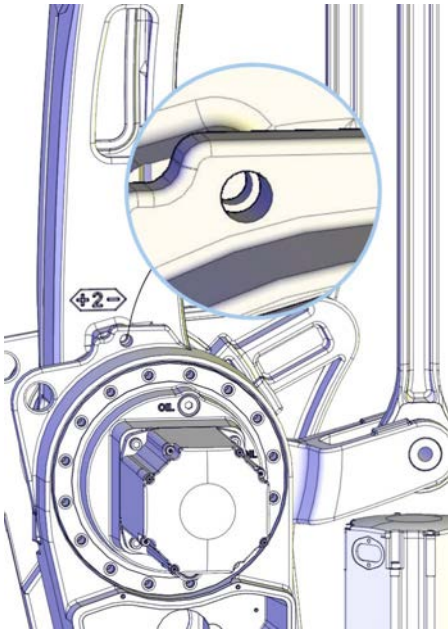
	Action	Note
2	<p> DANGER</p> <p>Turn off all:</p> <ul style="list-style-type: none"> • electric power supply • hydraulic pressure supply • air pressure supply <p>to the robot, before entering the robot working area.</p>	
3	<p>Secure the lower arm with a <i>lock screw M16x90</i> in the hole as shown in the figure.</p>	 <p>xx1000001179</p>
4	<p>Remove the <i>linkage</i> starting with upper link arm.</p>	<p>See sections:</p> <ul style="list-style-type: none"> • Replacing linkage - upper link arm on page 240 • Replacing linkage - lower link arm on page 248 • Replacing the linkage - link on page 255
5	<p>Remove the <i>parallel rod</i>.</p>	<p>See section Replacing parallel rod on page 272.</p>
6	<p>Remove the <i>cable harness</i> in upper and lower arms.</p> <p>Secure the cable harness in a way that it is protected from getting damaged and from oil spill.</p>	<p>See sections:</p> <ul style="list-style-type: none"> • Replacing cable harness, lower end (axes 1-3) on page 151 • Replacing the cable harness, upper end (incl. axis 6) on page 161
7	<p>Remove the <i>complete upper arm</i>.</p>	<p>See section Replacing the upper arm on page 223.</p>
8	<p>Remove the cover on <i>motors axes 2-3</i> and disconnect the motor cables.</p> <p>Motors are removed in order to be able to rotate lower and parallel arms.</p>	<p>See section Replacing motors, axes 2 and 3 on page 309.</p>

Continues on next page



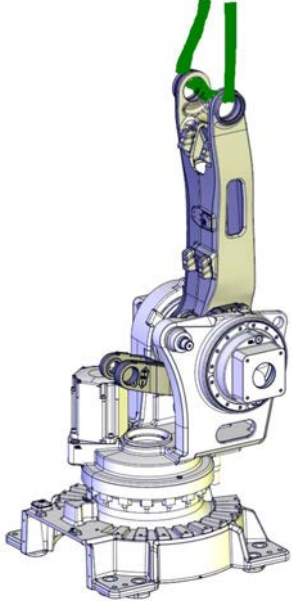
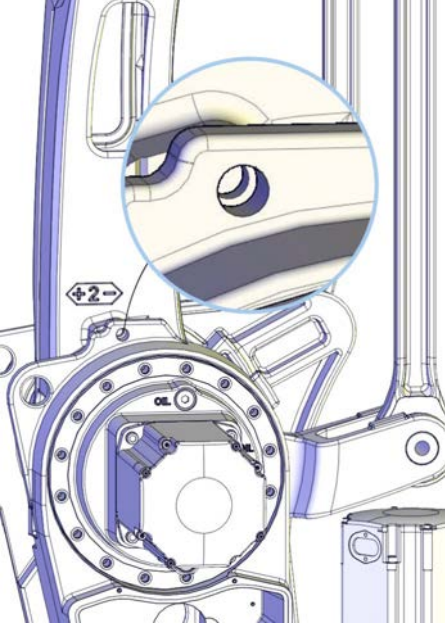

4 Repair

4.4.9 Replacing the complete lower arm system

Continued

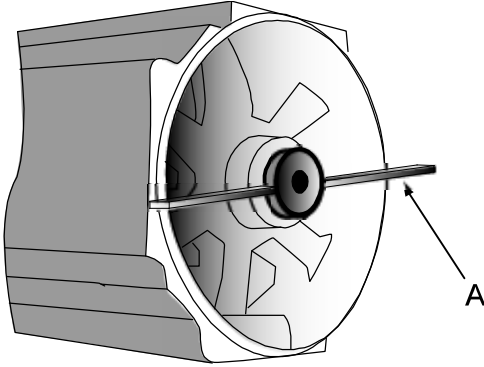
	Action	Note
9	 CAUTION The robot lower arm weighs 110 kg. All lifting accessories used must be sized accordingly!	
10	Secure the <i>complete lower arm system</i> with a <i>roundsling</i> in an overhead crane or similar.	 xx1100000179
11	Remove the <i>lock screw</i> securing the lower arm system.	 xx1000001179
12	In order to release the brake, connect the <i>24VDC power supply</i> .	Connect to connector R2.MP2 or R2.MP3 depending on which side: <ul style="list-style-type: none">• + : pin 2• -: pin 5

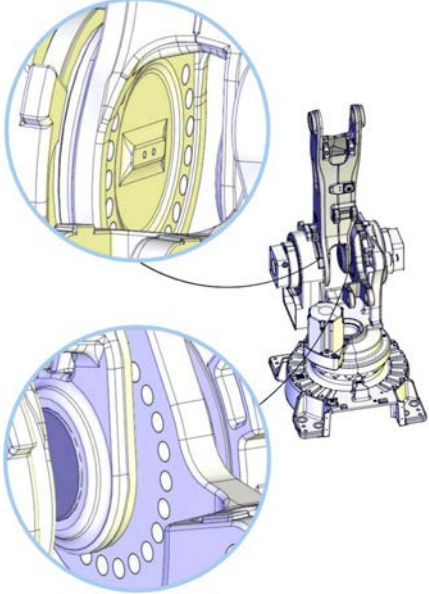
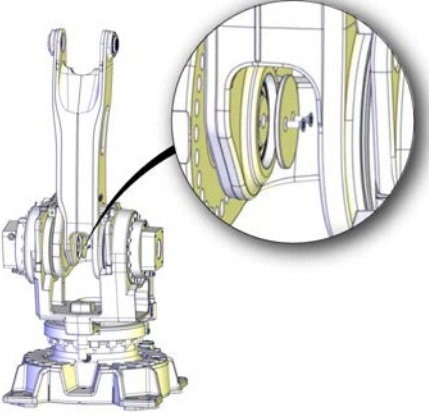
Continues on next page



Action	Note
<p>13 Remove all <i>attachment screws (M12)</i> securing the lower arm system, on both sides.</p>  <p>xx0200000165</p> <p>A: Rotation tool</p> <p> Note</p> <p>The lower and parallel arms need to be rotated in order to reach all attachment screws. Release the brake and use a <i>rotation tool</i> fitted to the motor axis.</p>	 <p>xx1100000180</p>
<p>14 Remove the two screws, and remove the <i>sealing cover</i>.</p>	 <p>xx1100000181</p>
<p>15 The space between gearboxes is cramp. Therefore push the lower and parallel arms together with the help of an iron bar or similar before removing them.</p>	<p> Note</p> <p>If the parts are not pushed together, it will be difficult to remove the complete lower arm.</p>

Continues on next page

4 Repair

4.4.9 Replacing the complete lower arm system

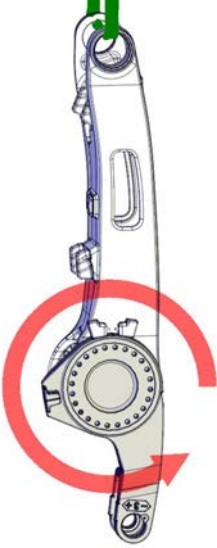
Continued

Action	Note
<p>16  DANGER</p> <p>Before removing the lower arm system the parallel arm must be secured to the lower arm. If not secured the parallel arm can fall down and cause a serious accident!</p>	 <p>xx110000182</p>
<p>17 Move the parallel arm and secure it to the lower arm as shown in the figure, to prevent it from falling down.</p>	 <p>xx110000178</p>

Continues on next page

4.4.9 Replacing the complete lower arm system
Continued

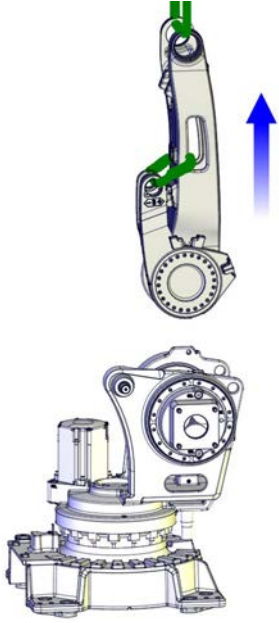
	Action	Note
18	Remove the <i>complete lower arm system</i> .	 <p>xx1100000183</p>
19	How to remove the <i>parallel arm</i> is described in section Replacing the parallel arm on page 293 .	

Refitting the lower arm system

Use this procedure to refit the lower arm system.





	Action	Note
1	Fit the <i>parallel arm</i> to the lower arm.	See section <ul style="list-style-type: none"> • Replacing the parallel arm on page 293
2	 CAUTION The robot lower arm weighs 110 kg. All lifting accessories used must be sized accordingly!	

Continues on next page

4 Repair

4.4.9 Replacing the complete lower arm system

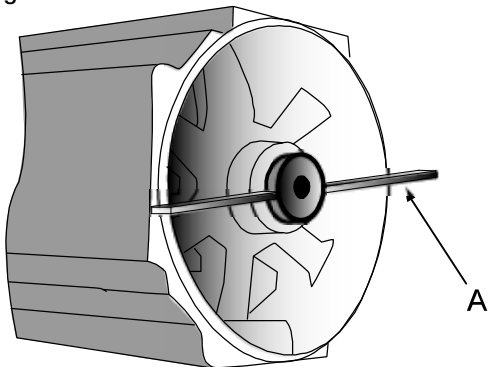
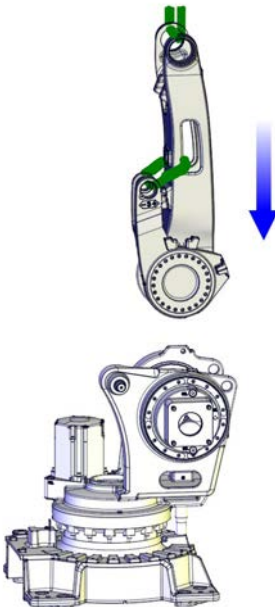
Continued

Action	Note
<p>3 Fit a <i>roundsling</i>, to the lower arm system and lift it up.</p> <p> DANGER</p> <p>Secure the parallel arm to the lower arm before lifting the lower arm system. If not secured, the parallel arm can fall down and cause a serious accident!</p>	 <p>xx1100000184</p>
<p>4 In order to release the brake, connect the <i>24VDC power supply</i>.</p>	<p>Connect to connector R2.MP2 or R2.MP3 depending on which side:</p> <ul style="list-style-type: none"> • + : pin 2 • - : pin 5
<p>5 Place the lower arm system in its mounting position.</p> <p>If the hole pattern need to be adjusted, release the brake and use a <i>rotation tool</i> to find the correct hole pattern by moving the gears.</p>  <p>xx0200000165</p> <p>A: Rotation tool</p>	<p>For art. no. see:</p> <ul style="list-style-type: none"> • Required equipment on page 283  <p>xx1100000185</p>
<p>6  Note</p> <p>Refit the axis 2 side first!</p>	

Continues on next page

4.4.9 Replacing the complete lower arm system

Continued

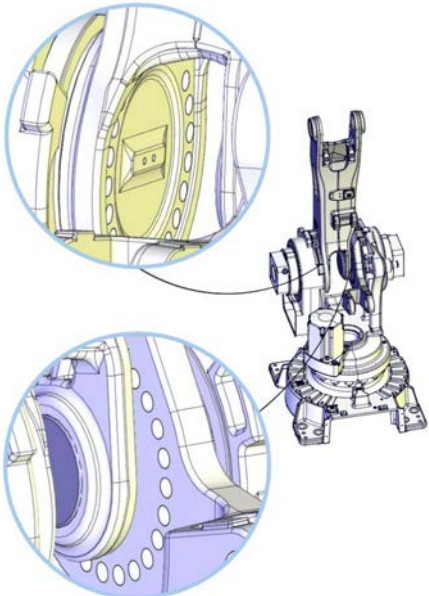
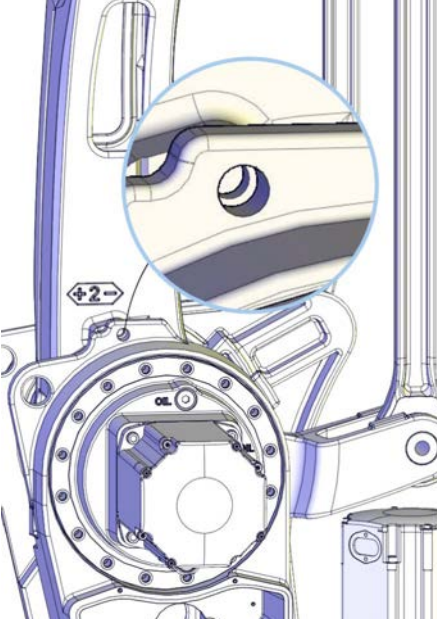

	Action	Note
7	Refit all <i>M12 attachment screws</i> with washers on the <i>axis 2 side</i> that are possible to fit at this stage.	<p>Tightening torque M12: 120 Nm</p>  <p>xx1100000180</p>
8	Push the parallel arm against the axis 3 side with the help of an iron bar or similar.	
9	Refit all <i>M12 attachment screws</i> with washers on the <i>axis 3 side</i> that are possible to fit. See figure above!	Tightening torque M12: 120 Nm
10	Change the position of the lower arm in order to reach the remaining attachment holes, and fit the remaining screws.	
11	Secure the lower arm by fitting a <i>lock screw M16x90</i> .	 <p>xx1000001179</p>

Continues on next page

4 Repair

4.4.9 Replacing the complete lower arm system

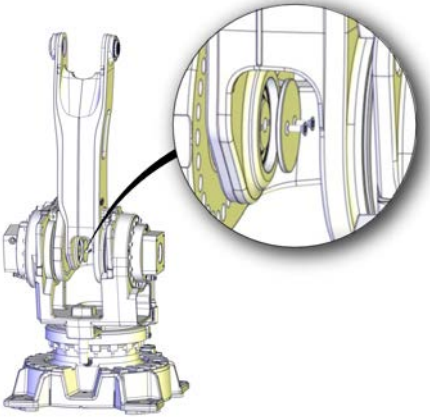
Continued

Action	Note
12 Refit the <i>sealing cover</i> , and secure with the two screws.	 <p>xx1100000181</p>
13 Reconnect the <i>motor cables axes 2-3</i> and refit the cover.	See section Replacing motors, axes 2 and 3 on page 309 .
14 Refit the <i>complete upper arm</i> .	See section Replacing the upper arm on page 223 .
15 Refit the <i>cable harness</i> in the upper arm and lower arms.	See Replacing the cable harness, upper end (incl. axis 6) on page 161 and Replacing cable harness, lower end (axes 1-3) on page 151 .
16 Refit the <i>parallel rod</i> .	See section Replacing parallel rod on page 272
17 Refit the <i>linkage</i> starting with the link.	See sections: <ul style="list-style-type: none"> • Replacing the linkage - link on page 255 • Replacing linkage - lower link arm on page 248 • Replacing linkage - upper link arm on page 240
18 Remove the <i>lock screw</i> .	
19 Recalibrate the robot.	Axis Calibration is described in Calibrating with Axis Calibration method on page 370 . General calibration information is included in section Calibration on page 359 .
20 <div style="display: flex; align-items: center; margin-top: 10px;">  <p>DANGER</p> </div> <p>Make sure all safety requirements are met when performing the first test run. See Test run after installation, maintenance, or repair on page 97.</p>	

4.4.10 Replacing the parallel arm

Location of parallel arm

The parallel arm is located as shown in the figure.

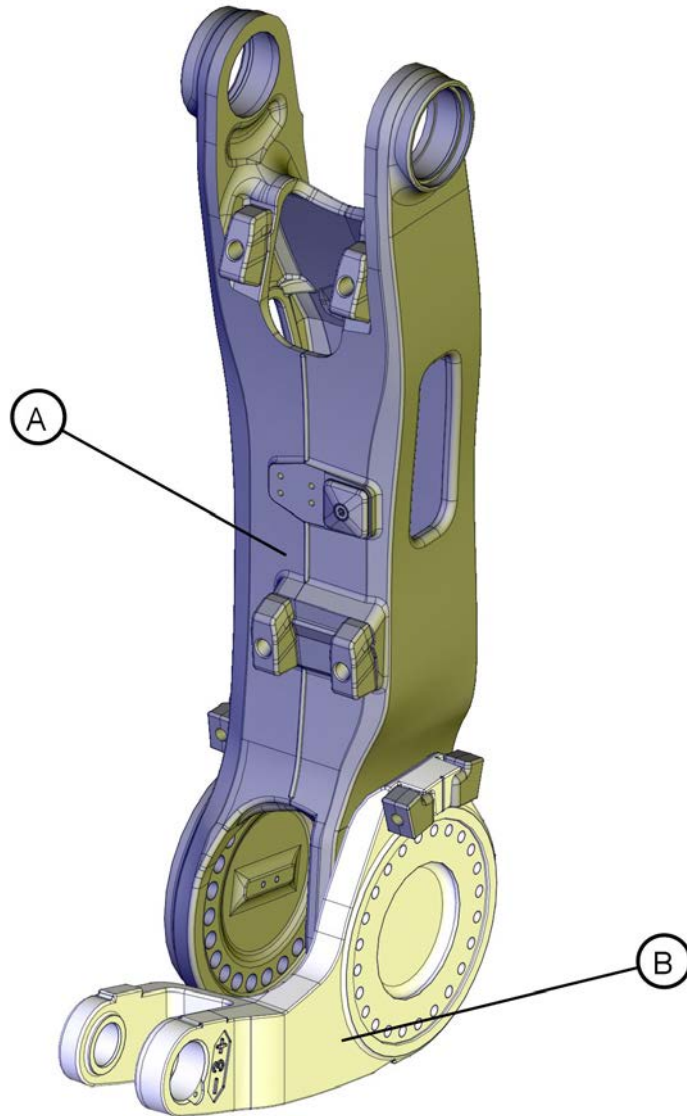

xx110000176

- A Lower arm
- B Parallel arm

Required equipment

Equipment, etc.	Art.no.	Note
Parallel arm	For spare part no. see: • Spare parts on page 403	
Bearing grease	3HAB3537-1	

Continues on next page

4 Repair

4.4.10 Replacing the parallel arm

Continued

Equipment, etc.	Art.no.	Note
Standard toolkit	-	Content is defined in section Standard tools on page 398 .
Press equipment	3HAC076749-001	For replacing the bearings on parallel arm. User instructions are enclosed with the tool.
Other tools and procedures may be required. See references to these procedures in the step-by-step instructions below.		These procedures include references to the tools required.

Deciding calibration routine

Decide which calibration routine to be used, based on the information in the table. Depending on which routine is chosen, action might be required prior to beginning the repair work of the robot, see the table.





	Action	Note
1	Decide which calibration routine to use for calibrating the robot. <ul style="list-style-type: none">Reference calibration. External cable packages (DressPack) and tools can stay fitted on the robot.Fine calibration. All external cable packages (DressPack) and tools must be removed from the robot.	
	If the robot is to be calibrated with reference calibration: Find previous reference values for the axis or create new reference values. These values are to be used after the repair procedure is completed, for calibration of the robot. If no previous reference values exist, and no new reference values can be created, then reference calibration is not possible.	Follow the instructions given in the reference calibration routine on the FlexPendant to create reference values. Creating new values requires possibility to move the robot. Read more about reference calibration for Axis Calibration in Reference calibration routine on page 371 .
	If the robot is to be calibrated with fine calibration: Remove all external cable packages (DressPack) and tools from the robot.	

Removing the parallel arm

Use this procedure to remove the parallel arm.

	Action	Note
1	Decide which calibration routine to use, and take actions accordingly prior to beginning the repair procedure.	
2	Remove the <i>complete lower arm system</i> from the robot.	See section Replacing the complete lower arm system on page 283 .

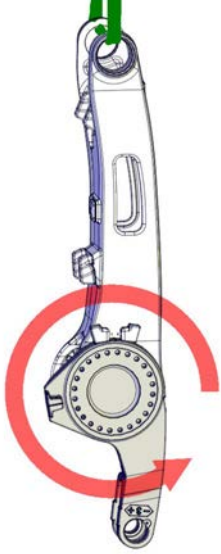
Continues on next page





	Action	Note
3	<p> DANGER</p> <p>Turn off all:</p> <ul style="list-style-type: none"> • electric power supply • hydraulic pressure supply • air pressure supply <p>to the robot, before entering the robot working area.</p>	
4	<p> DANGER</p> <p>Secure the parallel arm to the lower arm before lifting the lower arm system. If not secured, the parallel arm can fall down and cause a serious accident!</p>	 <p>xx110000182</p>
5	<p> CAUTION</p> <p>The robot lower arm weighs 110 kg. All lifting accessories used must be sized accordingly!</p>	

Continues on next page

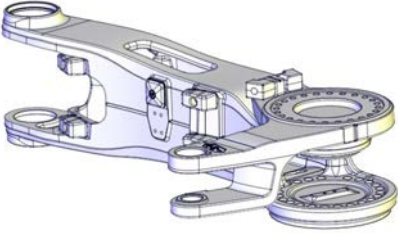

4 Repair

4.4.10 Replacing the parallel arm

Continued

Action	Note
<p>6 Secure the <i>lower arm system</i> as shown in the figure.</p>	 <p>xx110000184</p>
<p>7 Put the lower arm system on a workbench as shown in the figure.</p> <p> Tip</p> <p>Removal of the parallel arm is best performed on a workbench.</p>	 <p>xx110000186</p>
<p>8  CAUTION</p> <p>The parallel arm system weighs 40 kg. All lifting accessories used must be sized accordingly!</p>	
<p>9 Secure the <i>parallel arm</i> with a roundsling in an overhead crane.</p>	

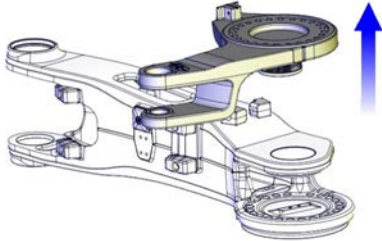
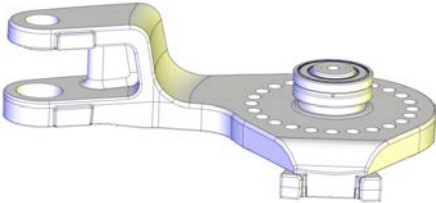
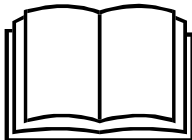
Continues on next page

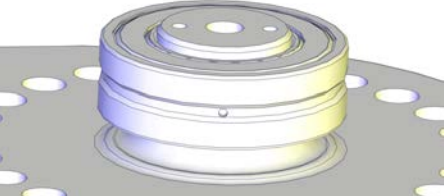
Action	Note
<p>10 Remove the parallel arm from the lower arm by lifting it straight up.</p> <p> Tip</p> <p>If needed use a plastic mallet and hit the parallel arm from inside.</p>	 <p>xx1100000187</p>
<p>11 Turn the <i>parallel arm</i> over and put it on a workbench or similar, as shown in the figure.</p>	 <p>xx1100000189</p>
<p>12 If needed, replace bearings, using the <i>press equipment, parallel arm</i>, according to user instructions enclosed with the equipment.</p> <p></p> <p>xx0900000813</p> <p>Go to the user instructions enclosed with the press tool.</p> <p> DANGER</p> <p>Handling the tool incorrectly will cause serious injury.</p> <p>Read and follow enclosed user instructions for the tool.</p>	 <p>xx1100000218</p>

Continues on next page

4 Repair

4.4.10 Replacing the parallel arm



Continued

Refitting the parallel arm

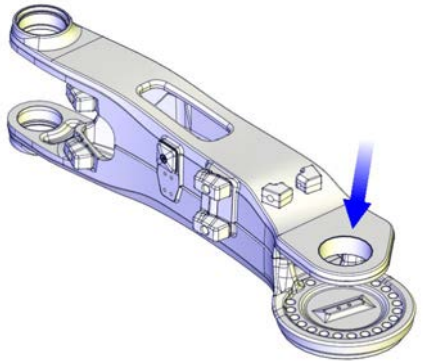
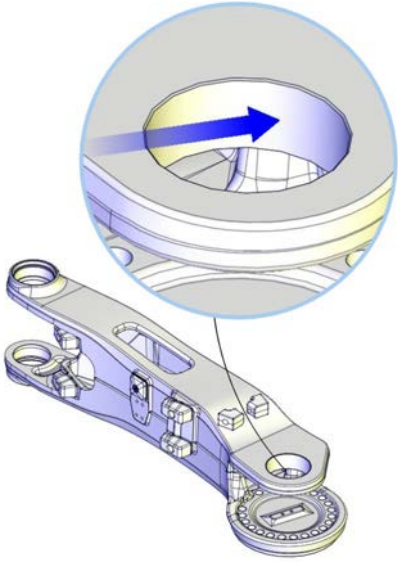
Use this procedure to refit the parallel arm.

	Action	Note
1	Refitting the parallel arm is best performed on a workbench.	
2	Check that the assembly and the condition of the <i>bearing</i> is good.	
3	Check that the lower arm is placed on the workbench as shown in the figure with the hole for the bearing pointing up.	 <p data-bbox="957 1173 1066 1196">xx110000193</p>
4	Apply some <i>grease</i> in the hole for the bearing.	<p data-bbox="957 1227 1391 1285">Art. no. is specified in <i>Required equipment on page 293</i></p>  <p data-bbox="957 1917 1066 1939">xx110000192</p>

Continues on next page

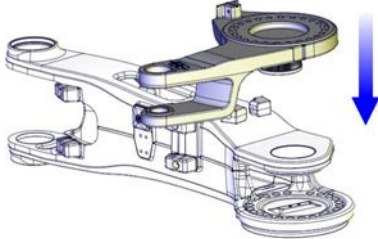
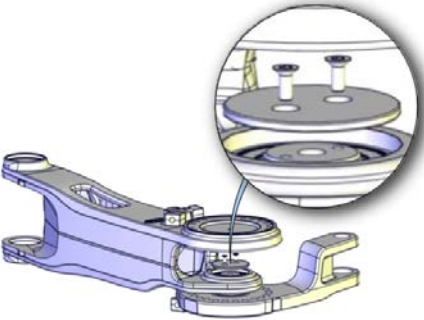
	Action	Note
5	 CAUTION The parallel arm system weighs 40 kg. All lifting accessories used must be sized accordingly!	
6	Lift the <i>parallel arm</i> to where the lower arm is placed.	
7	Push the <i>parallel arm</i> with bearing fitted, onto the lower arm.  Tip Use a plastic mallet if needed. Knock on the casting surface of the parallel arm.	 xx110000194
8	Refit the <i>sealing cover</i> , and secure with two screws.	 xx140000070
9	Refit the <i>complete lower arm system</i> .	See section Replacing the complete lower arm system on page 283 .
10	Recalibrate the robot.	Axis Calibration is described in Calibrating with Axis Calibration method on page 370 . General calibration information is included in section Calibration on page 359 .

Continues on next page

4 Repair

4.4.10 Replacing the parallel arm

Continued

	Action	Note
11	 DANGER Make sure all safety requirements are met when performing the first test run. See Test run after installation, maintenance, or repair on page 97 .	

4.5 Motors

4.5.1 Replacing motor, axis 1

Location of motor axis 1

The motor axis 1 is located on the left hand side of the robot as shown in the figure.

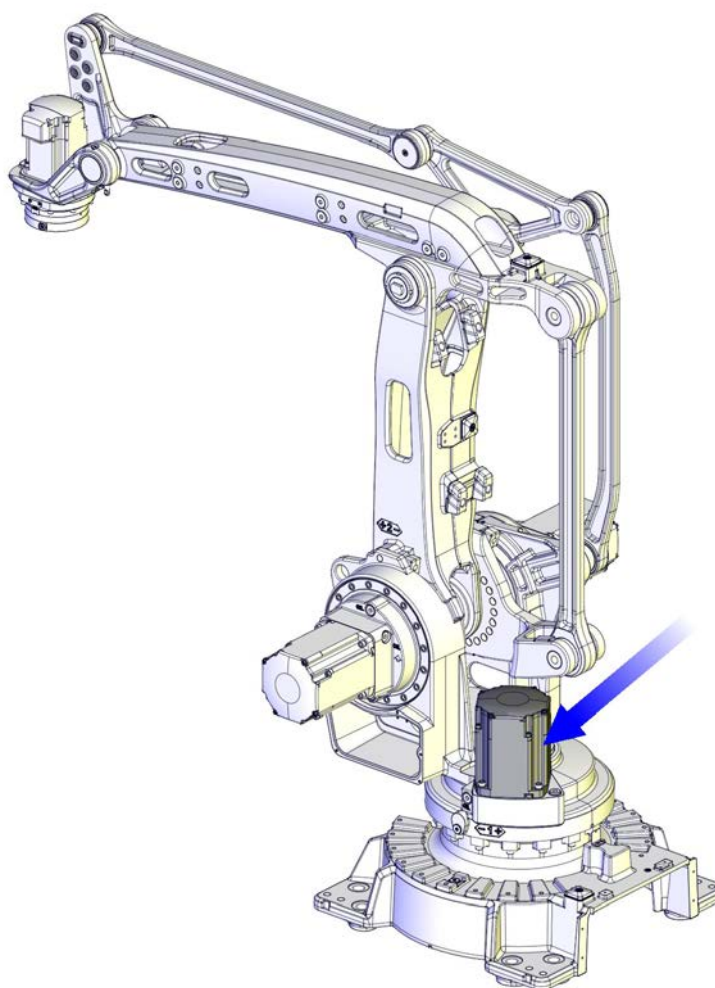

xx1000001171

Continues on next page

4 Repair

4.5.1 Replacing motor, axis 1

Continued

Required equipment

Equipment, etc	Art.no.	Note
Motor axis 1	For spare part number, see: <ul style="list-style-type: none"> Spare parts on page 403 	Includes: <ul style="list-style-type: none"> motor pinion o-ring (The old o-ring must be replaced when replacing the motor)
Screw	-	M12x100 fully, threaded
Grease	3HAC042536-001	Shell Gadus S2 For lubricating the o-ring.
Bits extension	3HAC12342-1	Used to reach the attachment screws for the motor.
Power supply	-	24 VDC, max. 1,5 A For releasing the brakes.
Standard toolkit	-	Content is defined in section Standard tools on page 398 .
Other tools and procedures may be required. See references to these procedures in the step-by-step instructions below.		These procedures include references to the tools required.
Circuit diagram		See chapter Circuit diagrams on page 405 .

Deciding calibration routine

Decide which calibration routine to be used, based on the information in the table. Depending on which routine is chosen, action might be required prior to beginning the repair work of the robot, see the table.

	Action	Note
1	Decide which calibration routine to use for calibrating the robot. <ul style="list-style-type: none"> Reference calibration. External cable packages (DressPack) and tools can stay fitted on the robot. Fine calibration. All external cable packages (DressPack) and tools must be removed from the robot. 	
	If the robot is to be calibrated with reference calibration: Find previous reference values for the axis or create new reference values. These values are to be used after the repair procedure is completed, for calibration of the robot. If no previous reference values exist, and no new reference values can be created, then reference calibration is not possible.	Follow the instructions given in the reference calibration routine on the FlexPendant to create reference values. Creating new values requires possibility to move the robot. Read more about reference calibration for Axis Calibration in Reference calibration routine on page 371 .
	If the robot is to be calibrated with fine calibration: Remove all external cable packages (DressPack) and tools from the robot.	

Continues on next page

Removing motor axis 1

Use this procedure to remove motor axis 1.

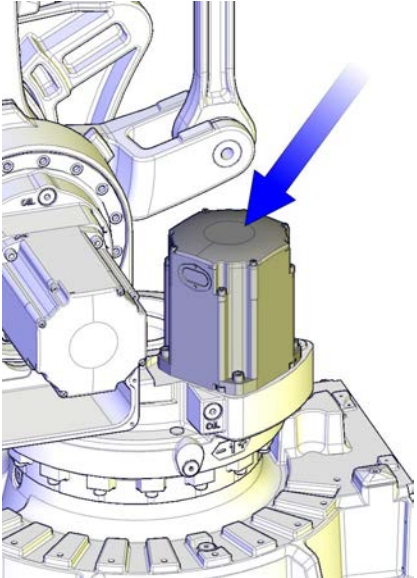
	Action	Note
1	Decide which calibration routine to use, and take actions accordingly prior to beginning the repair procedure.	
2	 DANGER Turn off all: <ul style="list-style-type: none"> • electric power supply • hydraulic pressure supply • air pressure supply to the robot, before entering the robot working area.	
3	Remove the <i>motor cover</i> to get access to the connectors on top of the motor.	 <p>xx1000001165</p>

Continues on next page



4 Repair

4.5.1 Replacing motor, axis 1

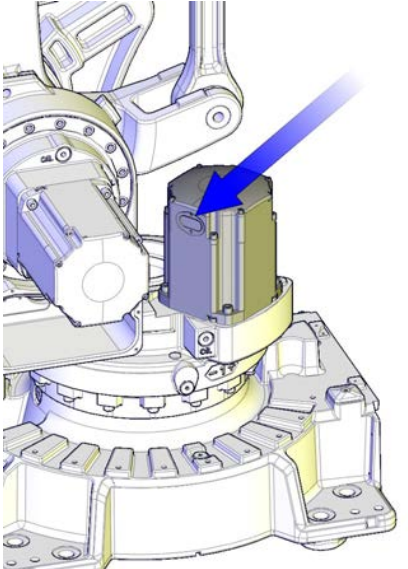
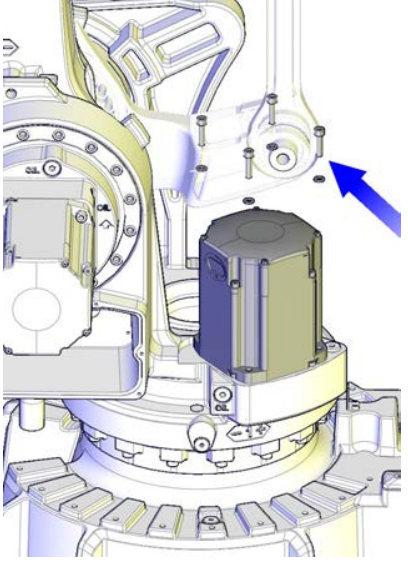
Continued

	Action	Note
4	<p>Remove the <i>cable gland cover</i> at the cable exit of the motor.</p> <p> Note</p> <p>Make sure the gasket is undamaged! Replace if damaged.</p>	 <p>xx1000001166</p>
5	Disconnect all connectors beneath the motor cover.	
6	In order to release the brake, connect the 24 VDC power supply.	<p>Connect to connector R2.MP1</p> <ul style="list-style-type: none">• + : pin 2• -: pin 5
7	Remove the <i>attachment screws</i> of the motor. Use the bits extension.	 <p>xx1000001167</p>

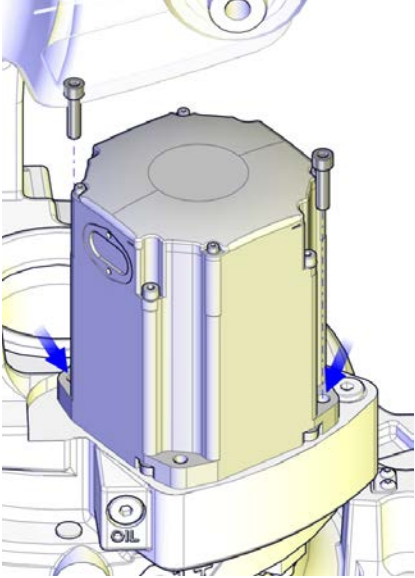
Continues on next page

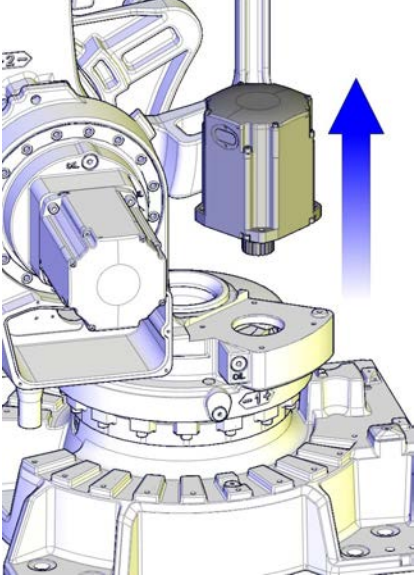
	Action	Note
8	<p>If required, press the motor out of position by fitting two screws in the holes on the motor for pressing out the motor.</p>	<p>Always use removal screws and tools in pairs! M12x100, fully threaded</p>  <p>xx110000087</p>
9	<p> CAUTION</p> <p>The motor weighs 29 kg. All lifting accessories used must be sized accordingly!</p>	
10	<p>Remove the motor by carefully lifting it straight up to get the pinion away from gear.</p> <p> CAUTION</p> <p>Be careful not to damage the pinion in the process!</p>	 <p>xx1000001168</p>
11	<p>Disconnect the brake release voltage.</p>	
12	<p>Check the pinion. If there is any damage, the pinion must be replaced.</p>	

Continues on next page



4 Repair

4.5.1 Replacing motor, axis 1

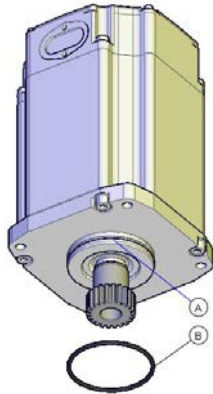

Continued

Refitting motor axis 1

Use this procedure to refit motor axis 1.

	Action	Note
1	Make sure the <i>o-ring</i> on the <i>circumference</i> of the motor is seated properly. Lightly lubricate the o-ring with <i>grease</i> .	 <p>xx1000001096</p> <p>Parts:</p> <ul style="list-style-type: none">A Circumference of motorB O-ring <p> Note</p> <p>The o-ring must be replaced when replacing the motor.</p>
2	 CAUTION The motor weighs 29 kg. All lifting accessories used must be sized accordingly!	
3	In order to release the brake, connect the 24 VDC power supply.	Connect to connector R2.MP1 <ul style="list-style-type: none">• + : pin 2• -: pin 5

Continues on next page

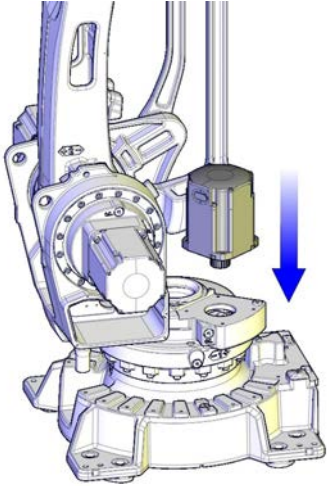
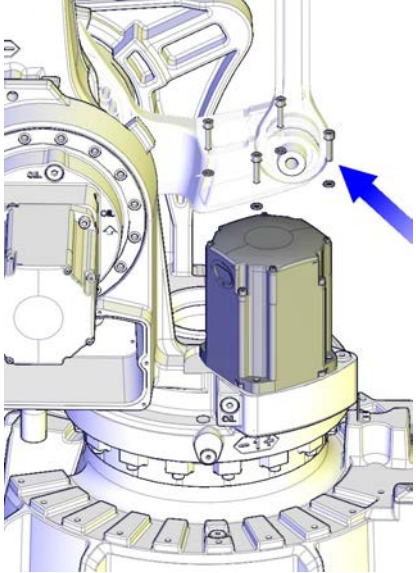



	Action	Note
4	<p>Gently lower the <i>motor</i> into the gear, making sure the <i>pinion</i> is properly mated to the gearbox of axis 1.</p> <p> Note</p> <p>Make sure the motor is turned the right way. See figure.</p> <p> Note</p> <p>Make sure the motor pinion does not get damaged!</p>	 <p>xx1000001169</p>
5	<p>Secure the motor with its four <i>attachment screws</i> and plain <i>washers</i>. Use the bits extension.</p>	 <p>xx1000001167</p> <p>Attachment screws:</p> <ul style="list-style-type: none"> • M10x40 quality 12.9 Gleitmo <p>Tightening torque:</p> <ul style="list-style-type: none"> • 50 Nm
6	<p>Disconnect the brake release voltage.</p>	
7	<p>Reconnect all connectors beneath the motor cover.</p>	

Continues on next page

4 Repair

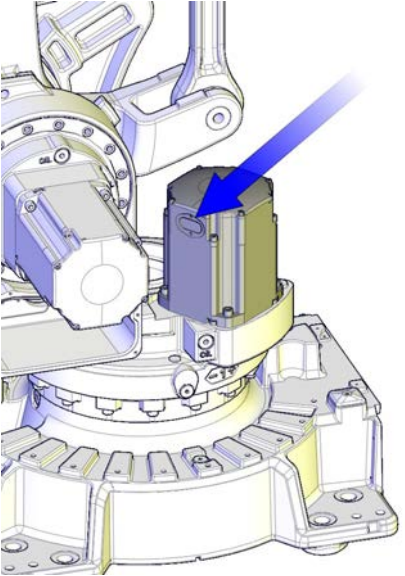
4.5.1 Replacing motor, axis 1

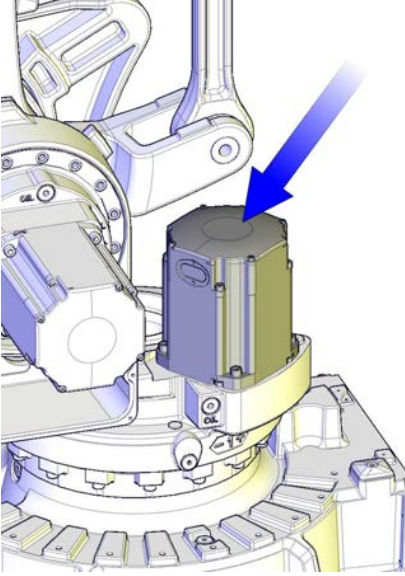
Continued

	Action	Note
8	<p>Refit the <i>cabl e gland cover</i> at the cable exit with its attachment screws.</p> <p> Note</p> <p>Make sure the cover is tightly sealed! Replace gasket if damaged.</p>	 <p>xx1000001166</p>
9	<p>Refit the <i>motor cover</i> with its attachment screws.</p> <p> Note</p> <p>Make sure the cover is tightly sealed!</p>	 <p>xx1000001165</p>
10	Recalibrate the robot!	<p>Axis Calibration is described in Calibrating with Axis Calibration method on page 370.</p> <p>General calibration information is included in section Calibration on page 359.</p>
11	<p> DANGER</p> <p>Make sure all safety requirements are met when performing the first test run. See Test run after installation, maintenance, or repair on page 97.</p>	

4.5.2 Replacing motors, axes 2 and 3

Location of motors, axes 2 and 3

The motors axes 2 and 3 are located on either side of the robot as shown in the figure.

The procedure is the same for both motors.

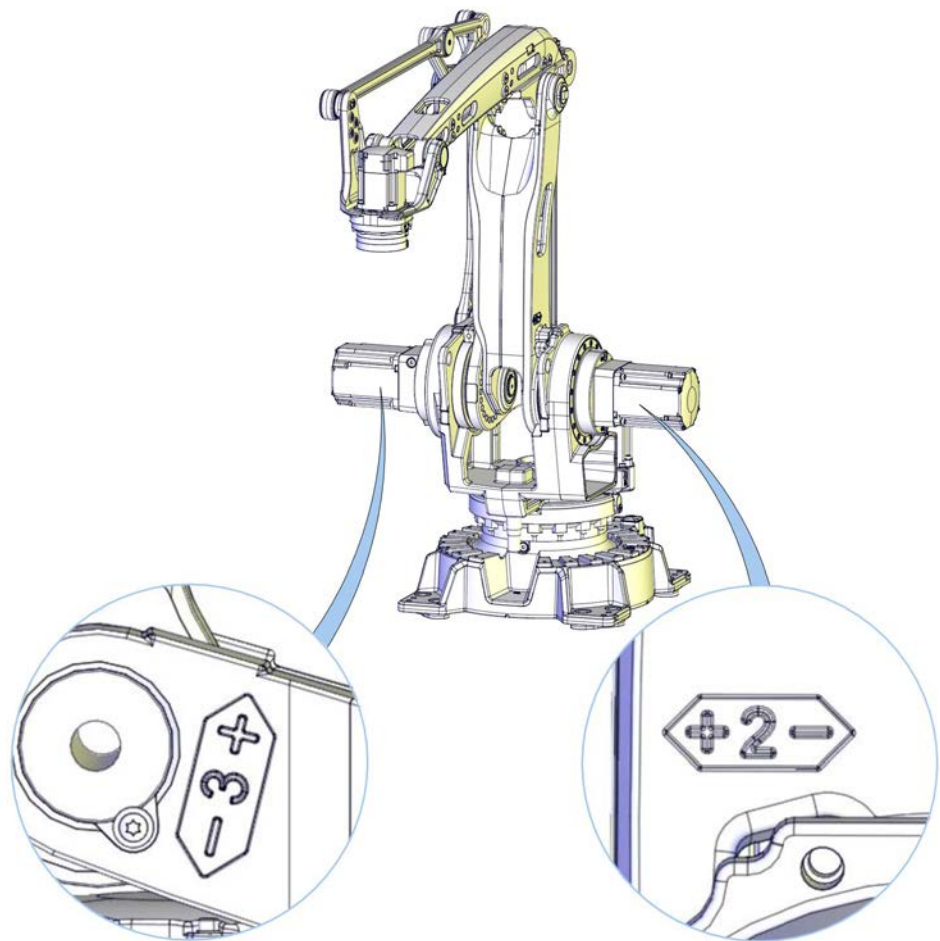

xx1000001174

Required equipment

Equipment, etc.	Art. no.	Note
Motor axes 2-3	For spare part no. see: <ul style="list-style-type: none"> • Spare parts on page 403 chapter 	Includes <ul style="list-style-type: none"> • motor • pinion • o-ring (the o-ring must be replaced when the motor is replaced)

Continues on next page

4 Repair

4.5.2 Replacing motors, axes 2 and 3

Continued

Equipment, etc.	Art. no.	Note
Grease	3HAC042536-001	Shell Gadus S2 For lubricating the o-ring.
Guide pins	3HAC13120-2	M10x150 For guiding the motor. Guide pins are to be used in pairs!
Lifting accessory, motor axes 2-3	3HAC15534-1	
Lock screw	-	M16x90 For securing the lower arm.
Bits extension	3HAC12342-1	Used to reach the attachment screws for the motor.
Power supply	-	24 VDC, 1.5 A For releasing the brakes.
Rotation tool		Used to rotate the motor pinion when mating it to the gear, when brakes are released with 24 VDC power supply.
Standard toolkit		Content is defined in section Standard tools on page 398 .
Other tools and procedures may be required. See references to these procedures in the step-by-step instructions below.		These procedures include references to the tools required.
Circuit diagram		See chapter Circuit diagrams on page 405 .

Deciding calibration routine

Decide which calibration routine to be used, based on the information in the table. Depending on which routine is chosen, action might be required prior to beginning the repair work of the robot, see the table.

	Action	Note
1	<p>Decide which calibration routine to use for calibrating the robot.</p> <ul style="list-style-type: none"> Reference calibration. External cable packages (DressPack) and tools can stay fitted on the robot. Fine calibration. All external cable packages (DressPack) and tools must be removed from the robot. 	
	<p>If the robot is to be calibrated with reference calibration:</p> <p>Find previous reference values for the axis or create new reference values. These values are to be used after the repair procedure is completed, for calibration of the robot.</p> <p>If no previous reference values exist, and no new reference values can be created, then reference calibration is not possible.</p>	<p>Follow the instructions given in the reference calibration routine on the FlexPendant to create reference values.</p> <p>Creating new values requires possibility to move the robot.</p> <p>Read more about reference calibration for Axis Calibration in Reference calibration routine on page 371.</p>



Continues on next page

Action	Note
<p>If the robot is to be calibrated with fine calibration: Remove all external cable packages (DressPack) and tools from the robot.</p>	

Removing motors axes 2 and 3

Use this procedure to remove motors axes 2 and 3.

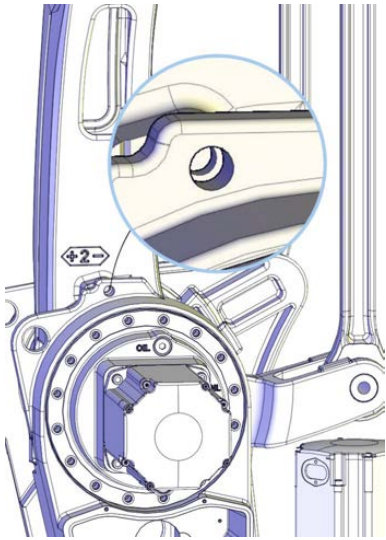
The procedure is the same for both motors.



Action	Note
1	Decide which calibration routine to use, and take actions accordingly prior to beginning the repair procedure.
2	Run the robot to a position close enough to its calibration position, to allow the lock screw to be inserted into the <i>hole for lock screw</i> . 
3	Lock the <i>lower arm</i> by inserting the <i>lock screw</i> into the hole of the frame. This is done in order to secure axis 2 from collapsing when the axis 2 motor is being removed.  CAUTION Tighten by hand!
4	Run axis 3 to the end position so that it rests against the mechanical stop. Release the brake of axis 3 in order to set the weight of axis 3 against the mechanical stop. This is done in order to secure axis 3 from collapsing when the axis 3 motor is being removed.

Continues on next page

4 Repair

4.5.2 Replacing motors, axes 2 and 3

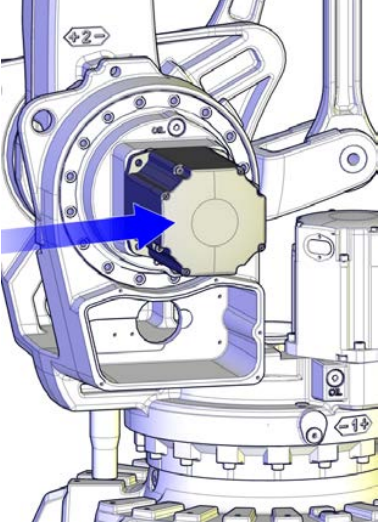
Continued

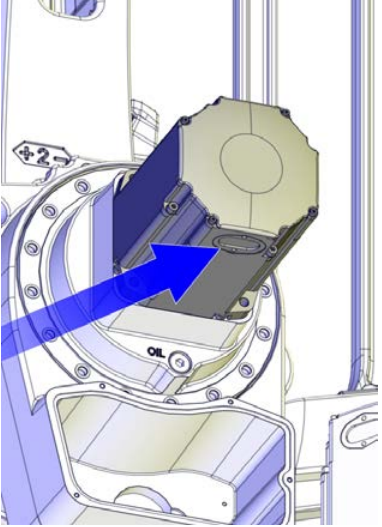
	Action	Note
5	 DANGER Turn off all: <ul style="list-style-type: none">• electric power supply• hydraulic pressure supply• air pressure supply to the robot, before entering the robot working area.	
6	Drain the oil from <i>gearbox</i> .	See section <ul style="list-style-type: none">• Changing oil, gearbox axes 2 and 3 on page 128.
7	Remove the <i>motor cover</i> .	 xx1000001182
8	Remove the <i>cable gland cover</i> at the cable exit.  Note Make sure the gasket is not damaged! Replace if damaged.	 xx1000001183
9	Disconnect all connectors beneath the motor cover.	

Continues on next page

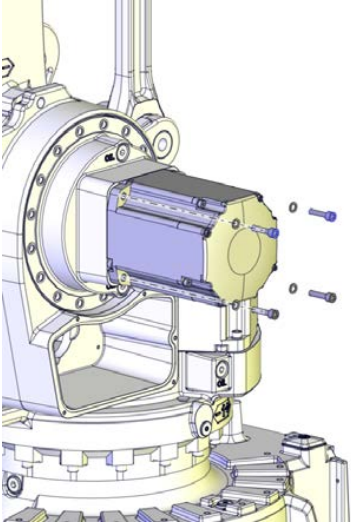
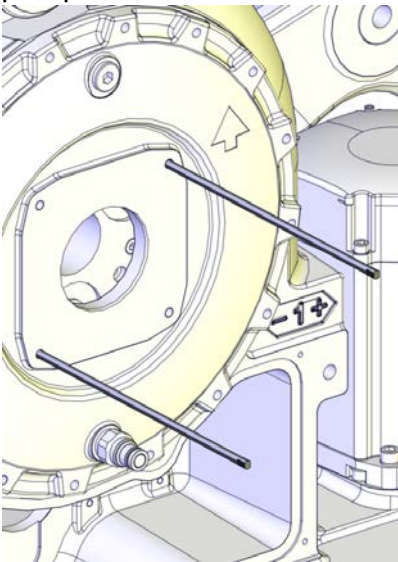

	Action	Note
10	In order to release the brake, connect the 24 VDC power supply.	Connect to connector R2.MP2 <ul style="list-style-type: none"> • + : pin 2 • - : pin 5
11	Unscrew <i>attachment screws</i> and <i>washers</i> of the motor. Use the <i>bits extension</i> .	 <p>xx1000001181</p>
12	Fit two <i>guide pins</i> in two of the motors attachment holes.	Art. no. is specified in Required equipment on page 309 . The figure shows IRB 760 but the principle is the same.  <p>xx1000001131</p>

Continues on next page

4 Repair

4.5.2 Replacing motors, axes 2 and 3

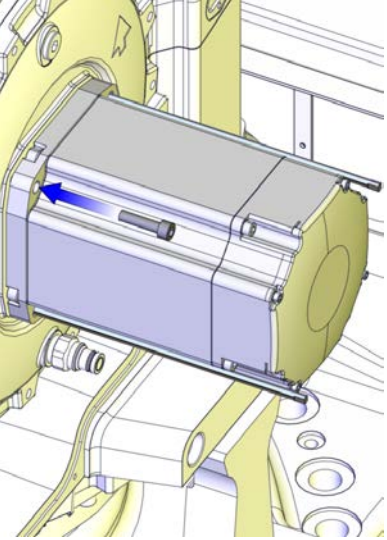
Continued

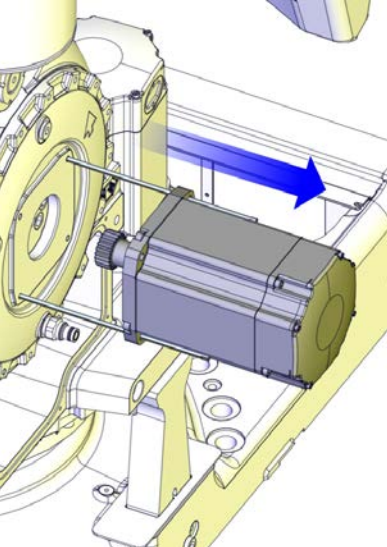
	Action	Note
13	If required, press the motor out of position by fitting two <i>screws</i> in the remaining attachment holes of the motor, diagonal to each other.	<p>M12x70, fully threaded. Always use the removal screws and tools in pairs!</p>  <p>xx1000001184</p>
14	Remove the two screws and fit the <i>lifting tool</i> , <i>motor axes 2-3</i> to the motor.	Art. no. is specified in Required equipment on page 309 .
15	<p> CAUTION</p> <p>The motor weighs 29 kg. All lifting accessories used must be sized accordingly!</p>	
16	Pull out the <i>motor</i> on the guide pins to get the pinion away from the gear. Make sure the pinion does not get damaged!	<p>The figure shows IRB 760 but the principle is the same.</p>  <p>xx1000001105</p>
17	Remove the motor by gently lifting it straight out and place it on a secure surface.	

Continues on next page

	Action	Note
18	Disconnect the brake release voltage!	
19	Check the pinion. If there is any damage, the motor pinion must be replaced.	

Refitting, motors axes 2 and 3

Use this procedure to refit motors axes 2 and 3.

The procedure is the same for both motors.

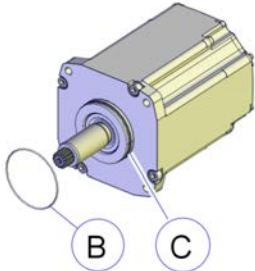

	Action	Note
1	Make sure the <i>o-ring</i> on the <i>circumference</i> of the motor is seated properly. Lightly lubricate the o-ring with grease.	 <p>xx1000001186</p> <p>Parts:</p> <ul style="list-style-type: none"> • B: O-ring • C: Circumference
2	In order to release the brake, connect the 24 VDC power supply.	Connect to connector R2.MP1 <ul style="list-style-type: none"> • + : pin 2 • - : pin 5
3	Fit the <i>lifting tool</i> , motor axes 2-3 to the motor.	Art. no. is specified in Required equipment on page 309 .

Continues on next page

4 Repair

4.5.2 Replacing motors, axes 2 and 3

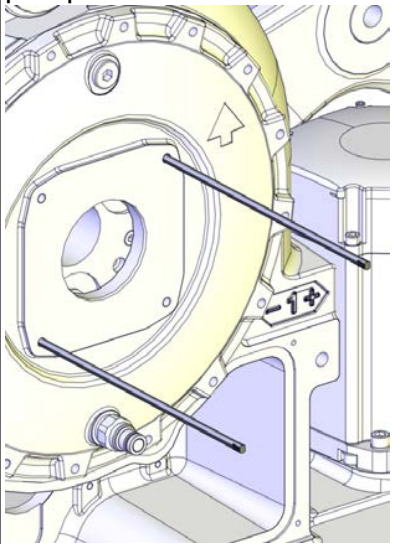
Continued

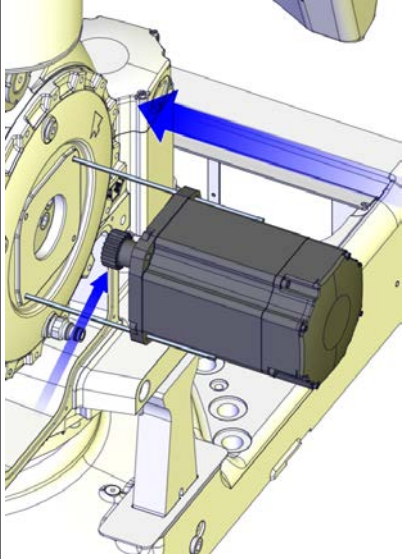
	Action	Note
4	Fit the two <i>guide pins</i> in the two lower motor attachment holes.	<p>Art. no. is specified in Required equipment on page 309.</p> <p>The figure shows IRB 760 but the principle is the same.</p>  <p>xx1000001131</p>
5	<p> CAUTION</p> <p>The motor weighs 29 kg. All lifting accessories used must be sized accordingly!</p>	
6	<p>Lift the <i>motor</i> and guide it on to the <i>guide pins</i>, as close to the correct position as possible without pushing the motor <i>pinion</i> into the gear.</p> <p> Note</p> <p>Make sure the motor is turned the right way, that is connections for the cables facing downwards.</p>	<p>The figure shows IRB 760 but the principle is the same.</p>  <p>xx1000001185</p>
7	Remove the lifting tool and allow the motor to rest on the guide pins.	

Continues on next page

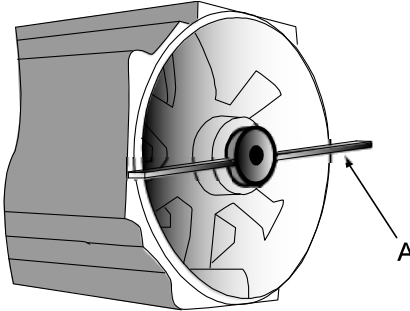
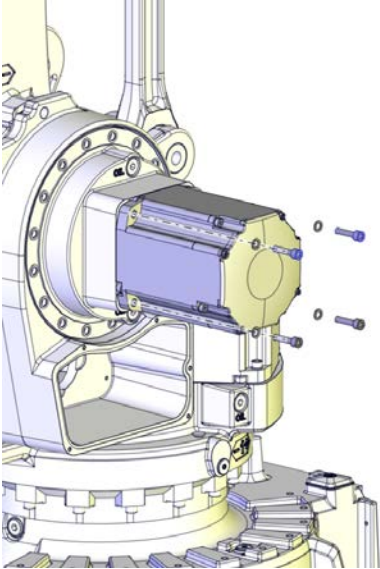

	Action	Note
8	<p>Use the <i>rotation tool</i> in order to rotate the motor pinion when mating it to the gear (see figure). Fit the motor, making sure the motor pinion is properly mated to the gear of gearbox axis 2-3 and that it doesn't get damaged.</p> <p> Note</p> <p>The rotation tool is used beneath the motor cover, directly on the motor shaft as shown in figure above.</p>	 <p>xx0200000165</p> <p>Part: Rotation tool</p>
9	Remove the guide pins.	
10	<p>Secure the motor with its four <i>attachment screws</i> and <i>plain washers</i>. Use the <i>bits extension</i>.</p> <p>Reused screws can be used, providing they are lubricated as detailed in section Screw joints on page 394 before fitting.</p>	 <p>xx1000001181</p> <p>Attachment screws:</p> <ul style="list-style-type: none"> • M10 x 40 quality 12.9 Gleitmo <p>Tightening torque:</p> <ul style="list-style-type: none"> • 50 Nm
11	Disconnect the brake release voltage.	
12	Reconnect all connectors beneath the motor cover.	Connect in accordance with markings on connectors.

Continues on next page

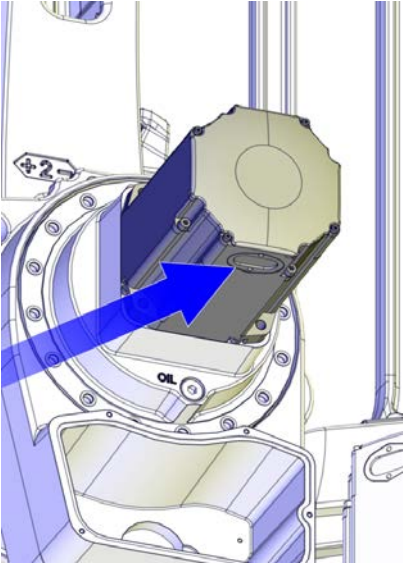

4 Repair

4.5.2 Replacing motors, axes 2 and 3

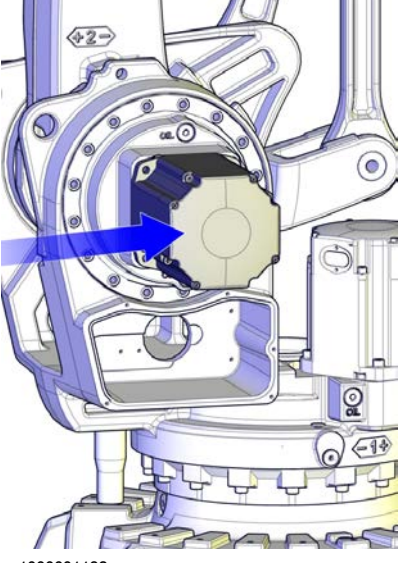
Continued

	Action	Note
13	<p>Refit the <i>cabl gland cover</i> at the cable exit with its two attachment screws.</p> <p> Note</p> <p>Use a new gasket!</p>	 <p>xx1000001183</p>
14	<p>Refit the <i>motor cover</i> with its attachment screws and washers.</p> <p> Note</p> <p>Make sure the cover is tightly sealed!</p>	 <p>xx1000001182</p>

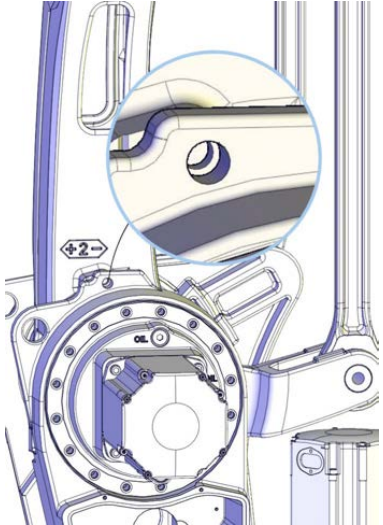
Continues on next page

	Action	Note
15	Remove the <i>lock screw</i> from the <i>hole for lock screw</i> .	 <p>xx1000001179</p>
16	Perform a leak-down test of the axis 2 or 3 gearbox.	See section Performing a leak-down test on page 142 .
17	Refill the gearbox with oil.	See section Changing oil, gearbox axes 2 and 3 on page 128 .
18	Recalibrate the robot!	<p>Axis Calibration is described in Calibrating with Axis Calibration method on page 370.</p> <p>General calibration information is included in section Calibration on page 359.</p>
19	 <p>DANGER</p> <p>Make sure all safety requirements are met when performing the first test run. See Test run after installation, maintenance, or repair on page 97.</p>	

4 Repair

4.5.3 Replacing motor, axis 6

4.5.3 Replacing motor, axis 6

Location of motor axis 6

Motor axis 6 is located in the center of the tilthouse as shown in the figure.

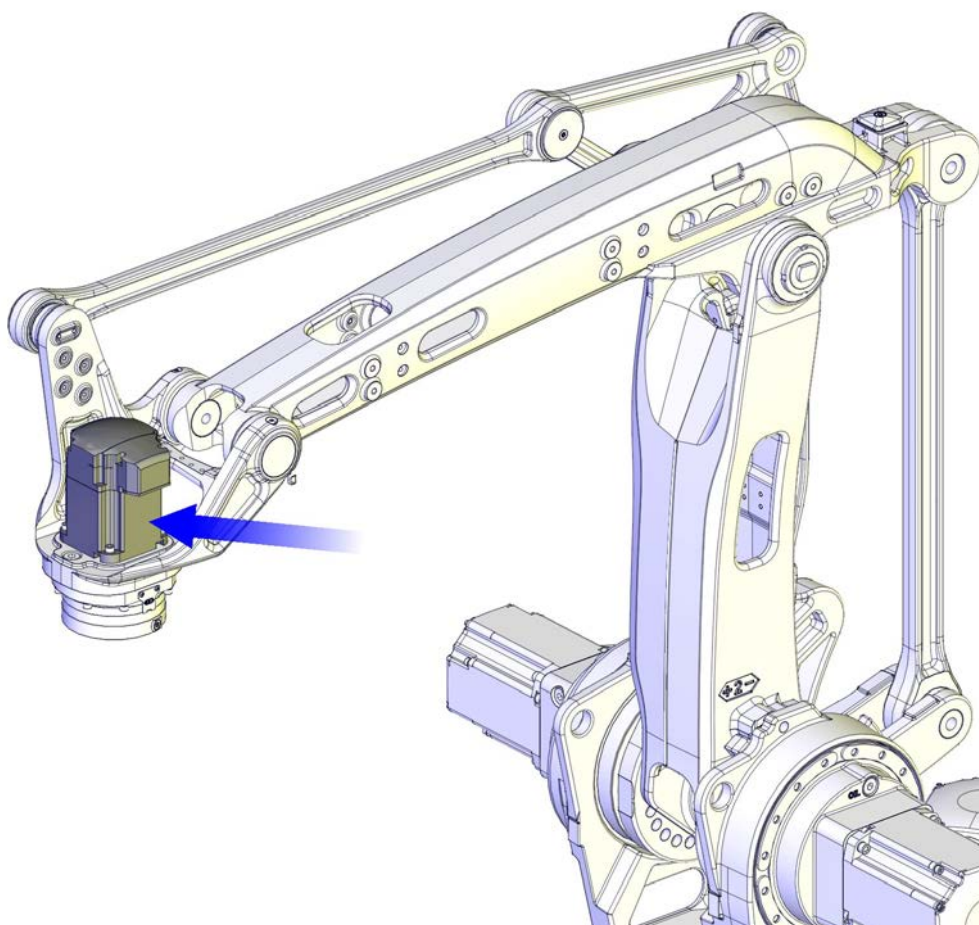

xx110000090

Required equipment

Equipment, etc.	Art.no.	Note
Motor axis 6	For spare part no. see: <ul style="list-style-type: none">• Spare parts on page 403	Includes <ul style="list-style-type: none">• motor• pinion• o-ring (the o-ring must be replaced when the motor is replaced)
Bits extension	3HAC12342-1	Used to reach attachment screws for motor.

Continues on next page

Equipment, etc.	Art.no.	Note
Locking liquid	3HAB7116-1	Loctite 243
Power supply	-	24 VDC, 1.5 A For releasing the brakes.
Grease	3HAC042536-001	Shell Gadus S2 For lubricating the o-ring.
Standard toolkit	-	Content is defined in section Standard tools on page 398 .
Other tools and procedures may be required. See references to these procedures in the step-by-step instructions below.		These procedures include references to the tools required.
Circuit diagram		See chapter Circuit diagrams on page 405 .

Deciding calibration routine

Decide which calibration routine to be used, based on the information in the table. Depending on which routine is chosen, action might be required prior to beginning the repair work of the robot, see the table.

	Action	Note
1	Decide which calibration routine to use for calibrating the robot. <ul style="list-style-type: none"> Reference calibration. External cable packages (DressPack) and tools can stay fitted on the robot. Fine calibration. All external cable packages (DressPack) and tools must be removed from the robot. 	
	<p>If the robot is to be calibrated with reference calibration:</p> <p>Find previous reference values for the axis or create new reference values. These values are to be used after the repair procedure is completed, for calibration of the robot.</p> <p>If no previous reference values exist, and no new reference values can be created, then reference calibration is not possible.</p>	<p>Follow the instructions given in the reference calibration routine on the FlexPendant to create reference values.</p> <p>Creating new values requires possibility to move the robot.</p> <p>Read more about reference calibration for Axis Calibration in Reference calibration routine on page 371.</p>
	<p>If the robot is to be calibrated with fine calibration:</p> <p>Remove all external cable packages (DressPack) and tools from the robot.</p>	

Removing, motor axis 6

Use this procedure to remove motor, axis 6.





	Action	Information
1	Decide which calibration routine to use, and take actions accordingly prior to beginning the repair procedure.	

Continues on next page

4 Repair

4.5.3 Replacing motor, axis 6

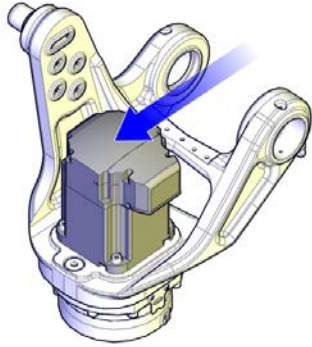
Continued

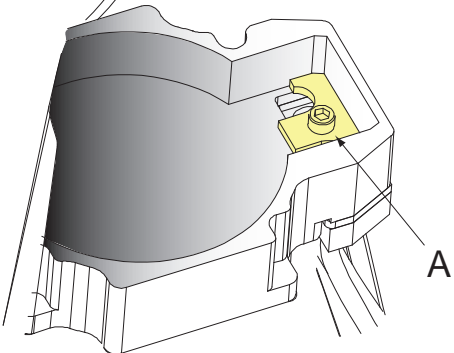
	Action	Information
2	<p>Run the robot to a position where it is easiest to remove the motor axis 6 when standing in front of the robot.</p> <p> Note</p> <p>The motor axis 6 can be replaced without draining the gear oil.</p>	
3	<p> DANGER</p> <p>Turn off all:</p> <ul style="list-style-type: none">• electric power supply• hydraulic pressure supply• air pressure supply <p>to the robot, before entering the robot working area.</p>	
4	<p>Remove <i>motor cover</i>.</p>	 <p>xx1000001223</p>
5	<p>Remove the <i>cable gland cover</i> at the cable exit by unscrewing its <i>attachment screw (A)</i> on the inside.</p> <p> Note</p> <p>Make sure the gasket is not damaged!</p>	 <p>xx0600002694</p>

Continues on next page

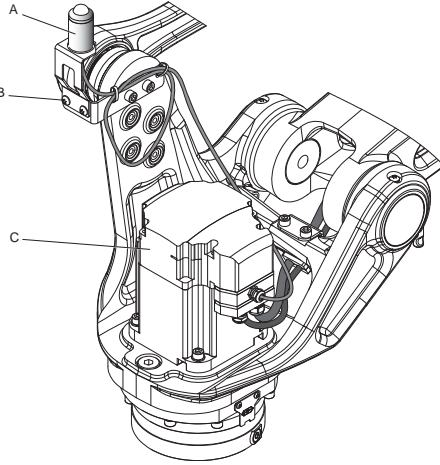
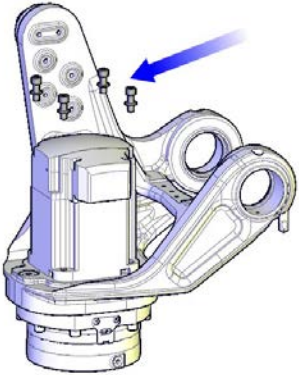
	Action	Information
6	<p>Disconnect all connectors beneath the cover.</p> <p> Note</p> <p>The connection to the <i>UL lamp</i>, must also be disconnected, if the robot is equipped with one.</p>	 <p>xx1000001287</p> <ul style="list-style-type: none"> A Signal lamp B Attachment screw M6x8 (2 pcs) C Motor cover
7	<p>In order to release the brake, connect the 24 VDC power supply.</p>	<p>Connect to connector R2.MP6</p> <ul style="list-style-type: none"> • + : pin 2 • -: pin 5
8	<p>Remove <i>attachment screws</i> and <i>washers</i>. Use the bits extension.</p>	 <p>xx1000001225</p>
9	<p>If required, press the motor out of position by fitting two screws in the motor attachment holes diagonal to each other</p>	<p>Always use the screws for removal in pairs!</p>

Continues on next page

4 Repair

4.5.3 Replacing motor, axis 6

Continued

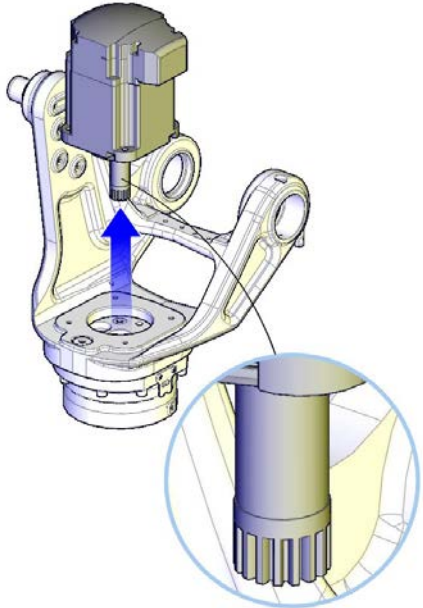
Action	Information
<p>10 Lift the motor carefully to get the <i>pinion</i> away from the gear.</p> <p> Note</p> <p>Make sure the <i>pinion</i> does not get damaged!</p>	 <p>xx1000001226</p>
<p>11 Disconnect the brake release voltage.</p>	
<p>12 Remove the motor by gently lifting it straight up and place it on a secure surface.</p>	

Refitting, motor axis 6

Use this procedure to refit motor axis 6.

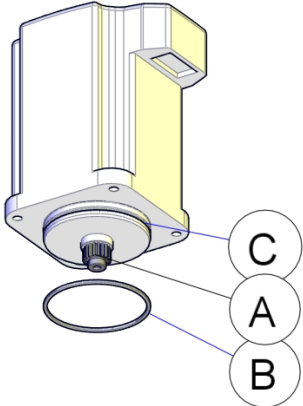
Action	Information
<p>1 Make sure the <i>o-ring</i> on the <i>circumference</i> of the motor is seated properly. Lightly lubricate the o-ring with grease.</p> <p> Note</p> <p>The o-ring must be replaced when the motor is replaced.</p>	 <p>xx1000001109</p> <p>Parts:</p> <ul style="list-style-type: none"> • A: Pinion • B: O-ring • C: Circumference

Continues on next page

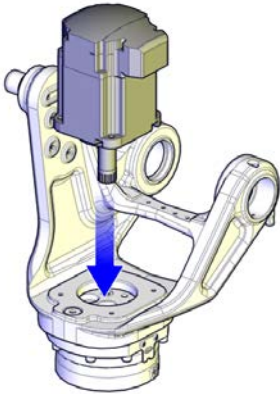
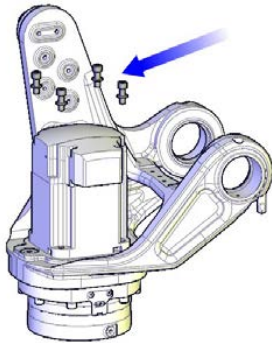
	Action	Information
2	In order to release the brake, connect the 24 VDC power supply.	Connect to connector R2.MP6 <ul style="list-style-type: none"> • + : pin 2 • - : pin 5
3	Fit the two <i>guide pins</i> in two of the motor attachment holes.	Art. no. is specified in Required equipment on page 320 .
4	<p>Lift the motor carefully in place. Make sure the motor <i>pinion</i> is properly mated to the gearbox, axis 6.</p> <p> Note</p> <p>Make sure the motor is turned the correct way. See figure!</p>	 <p>xx1000001228</p>
5	Remove the guide pins.	
6	Apply <i>locking liquid (Loctite 243)</i> on the attachment screws.	
7	<p>Secure the motor with its four <i>attachment screws</i> and <i>washers</i>.</p> <p>Reused screws may be used, providing they are lubricated as detailed in section Screw joints on page 394 before fitting.</p>	 <p>xx1000001225</p> <p>Washers:</p> <ul style="list-style-type: none"> • 8.4x16x1.6 quality Steel-A2F <p>Attachment screws:</p> <ul style="list-style-type: none"> • M10 x 40 quality 8.8-A2F <p>Tightening torque:</p> <ul style="list-style-type: none"> • 50 Nm

Continues on next page



4 Repair

4.5.3 Replacing motor, axis 6

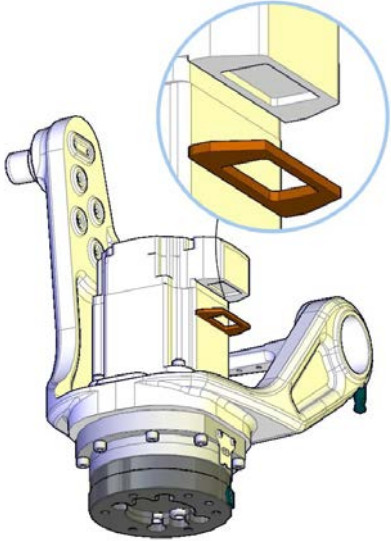
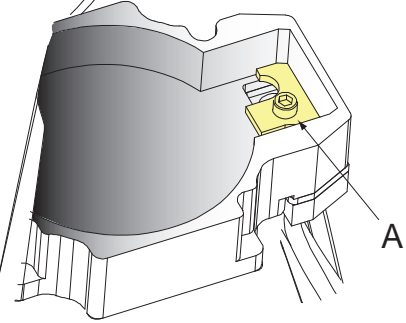
Continued

	Action	Information
8	Disconnect the brake release voltage.	
9	Perform a leak-down test of the axis 6 gearbox.	See section Performing a leak-down test on page 142 .
10	Reconnect all connectors in motor axis 6.	Connect in accordance with markings on connectors.
11	Refit the connections to the UL lamp, if the robot is equipped with one.	
12	Check the <i>gasket</i> . If damaged, replace it.	 <p data-bbox="991 1151 1102 1173">xx1000001224</p>
13	Refit the cable gland with its attachment screw.	 <p data-bbox="991 1541 1102 1563">xx0600002694</p> <ul data-bbox="1027 1576 1366 1630" style="list-style-type: none"> • A: Screw holding the cable gland <p data-bbox="991 1637 1410 1700">Make sure the gasket is not damaged! Replace if damaged.</p>

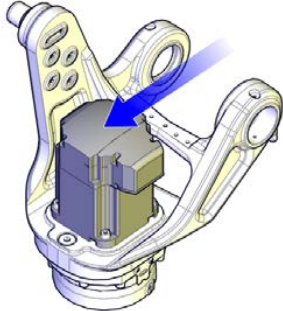
Continues on next page

	Action	Information
14	<p>Refit the cover, motor axis 6 with its <i>attachment screws and washers</i>.</p> <p> Note</p> <p>Make sure the cover is tightly sealed!</p>	 <p>xx1000001223</p>
15	<p>Re-calibrate the robot!</p>	<p>Axis Calibration is described in Calibrating with Axis Calibration method on page 370.</p> <p>General calibration information is included in section Calibration on page 359.</p>
16	<p> DANGER</p> <p>Make sure all safety requirements are met when performing the first test run. See Test run after installation, maintenance, or repair on page 97.</p>	

4 Repair

4.6.1 Replacing the axis 1 gearbox

4.6 Gearboxes

4.6.1 Replacing the axis 1 gearbox

Location of gearbox

The axis 1 gearbox is located between the frame and base as shown in the figure.

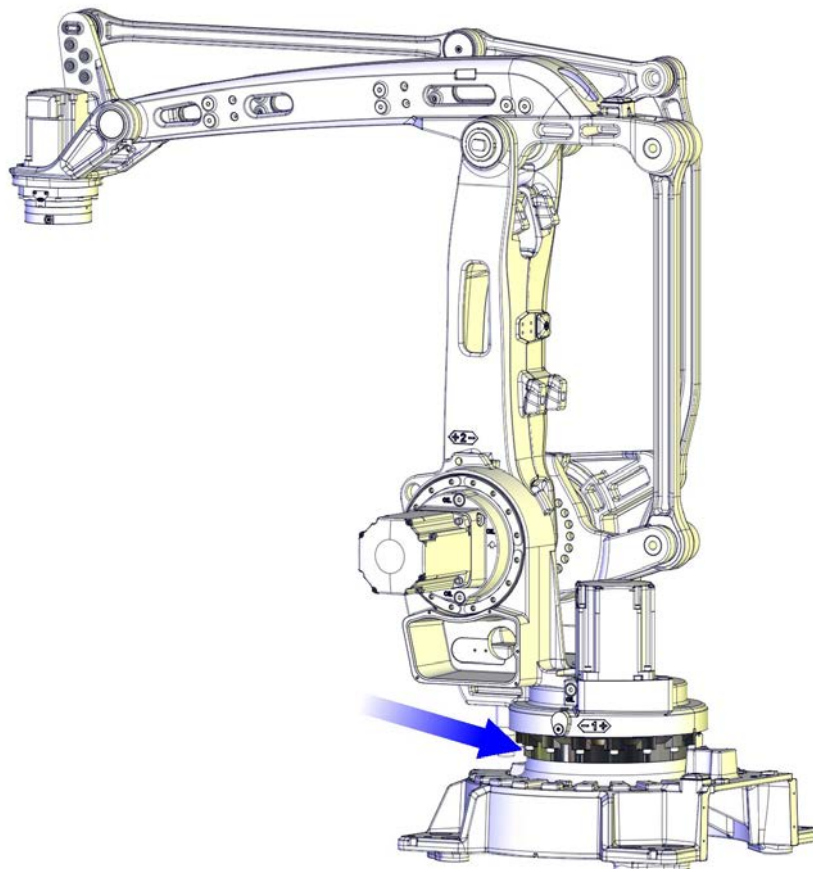

xx110000122

Required equipment

Equipment, etc.	Art. no.	Note
Gearbox	For spare part no. see: <ul style="list-style-type: none">• Spare parts on page 403.	Includes: <ul style="list-style-type: none">• gearbox• all o-rings and sealing rings
O-ring	3HAB3772-93	Replace if damaged!

Continues on next page

Equipment, etc.	Art. no.	Note
O-ring	3HAB3772-97	3 pcs Replace if damaged!
Oil seal	For spare part no. see: • Spare parts on page 403	Replace if damaged!
Grease	3HAC042536-001	Shell Gadus S2 For lubricating the o-ring.
Support, base and gear 1	3HAC15535-1	
Adapter	3HAC040381-001	
Lifting eye, M12	3HAC025333-005	2 pcs
Shackle		Lifting capacity: 1,000 kg.
Lifting accessory (chain)	3HAC15556-1	
Guide pins	3HAC022637-001	2 pcs, M12x130. Used for guiding the gearbox into place in the base. Always use guide pins in pairs!
Calibration tool box, Axis Calibration	3HAC074119-001	Delivered as a set of calibration tools. Required if Axis Calibration is the valid calibration method for the robot.
Standard toolkit	-	Content is defined in section Standard tools on page 398 .
Other tools and procedures may be required. See references to these procedures in the step-by-step instructions below.		These procedures include references to the tools required.

Deciding calibration routine

Decide which calibration routine to be used, based on the information in the table. Depending on which routine is chosen, action might be required prior to beginning the repair work of the robot, see the table.

	Action	Note
1	Decide which calibration routine to use for calibrating the robot. <ul style="list-style-type: none"> Reference calibration. External cable packages (DressPack) and tools can stay fitted on the robot. Fine calibration. All external cable packages (DressPack) and tools must be removed from the robot. 	

Continues on next page

4 Repair

4.6.1 Replacing the axis 1 gearbox

Continued

Action	Note
<p>If the robot is to be calibrated with reference calibration: Find previous reference values for the axis or create new reference values. These values are to be used after the repair procedure is completed, for calibration of the robot.</p> <p>If no previous reference values exist, and no new reference values can be created, then reference calibration is not possible.</p>	<p>Follow the instructions given in the reference calibration routine on the FlexPendant to create reference values.</p> <p>Creating new values requires possibility to move the robot.</p> <p>Read more about reference calibration for Axis Calibration in Reference calibration routine on page 371.</p>
<p>If the robot is to be calibrated with fine calibration: Remove all external cable packages (DressPack) and tools from the robot.</p>	



Removal, gearbox axis 1

Use this procedure to remove gearbox, axis 1.

	Action	Note
1	Decide which calibration routine to use, and take actions accordingly prior to beginning the repair procedure.	
2	Move the robot to its most stable position, shown in the figure to the right. Jog the robot to this position: Axis 2 = -40 degrees Axis 3 = +65 degrees	
3	 <p>DANGER</p> <p>Turn off all:</p> <ul style="list-style-type: none"> • electric power supply • hydraulic pressure supply • air pressure supply <p>to the robot, before entering the robot working area.</p>	
4	Drain the axis 1 gearbox.	See Changing oil, axis-1 gearbox on page 124 .
5	Remove the complete arm system.	See Replacing the base, including axis 1 gearbox on page 187 .
6	Unfasten the robot base from the foundation by removing the base attachment screws.	

Continues on next page

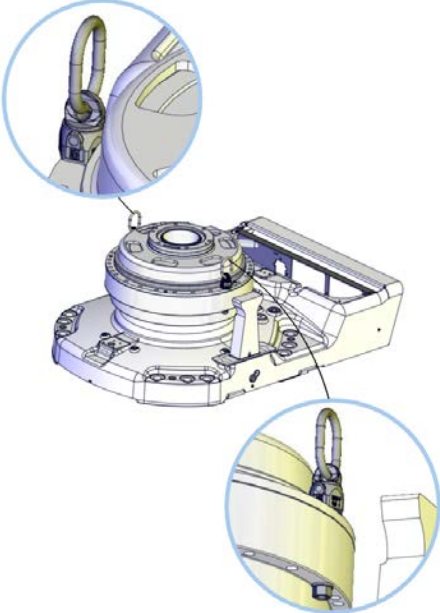
4.6.1 Replacing the axis 1 gearbox
Continued



	Action	Note
7	<p>Fit two <i>lifting eyes</i> on each side of the gearbox. Attach the <i>lifting accessory, base and gear 1</i> and a <i>roundsling</i>, to the gearbox and base.</p>	<p>The figure shows IRB 760 but is also valid for IRB 460.</p>  <p>xx1000001395</p> <p>Specified in Required equipment on page 328.</p>
8	<p> CAUTION</p> <p>The base and axis 1 gearbox weighs 130 kg + 108 kg. All lifting accessories used must be sized accordingly!</p>	
9	<p>Lift the robot base including the axis 1 gearbox to allow the <i>base and gear 1 support</i> be fitted on each sides of the base.</p>	<p>Art. no. is specified in Required equipment on page 328.</p>
10	<p>Secure the support to the base and to the foundation. Make sure the base remains in a stable position before performing any work underneath the base!</p>	<p>The figure shows IRB 760 but is also valid for IRB 460.</p>  <p>xx1000000364</p> <p>A Support base (4 pcs)</p>

Continues on next page

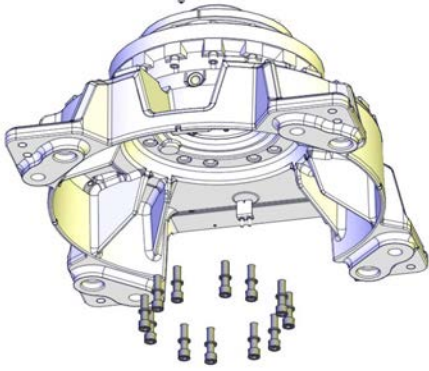
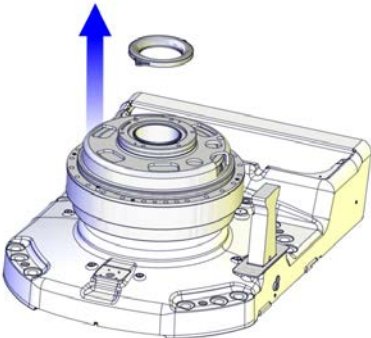

4 Repair

4.6.1 Replacing the axis 1 gearbox

Continued

	Action	Note
11	Remove the bottom plate from underneath the base in order to get access to the attachment screws.	
12	Unscrew the attachment screws and remove the washers.	 <p data-bbox="957 840 1066 857">xx110000207</p> <p data-bbox="957 878 1264 904">Attachment screws: 12 pcs.</p> <p data-bbox="957 911 1150 938">Washers: 12 pcs.</p>
13	Remove the cable guide in the center of gearbox 1 by unscrewing its attachment screws.	 <p data-bbox="957 1503 1066 1520">xx1000001387</p>
14	 CAUTION The gearbox weighs 108 kg. All lifting accessories used must be sized accordingly!	
15	Lift the gearbox away with the already mounted lifting tools.	

Continues on next page

	Action	Note
16	<p>Turn the gearbox, and remove the protection pipe by unscrewing two attachment screws.</p> <p> Note</p> <p>Move the protective pipe over to the new gearbox.</p>	 <p>xx1400000786</p>

Refitting, gearbox axis 1

Use this procedure to refit gearbox, axis 1.

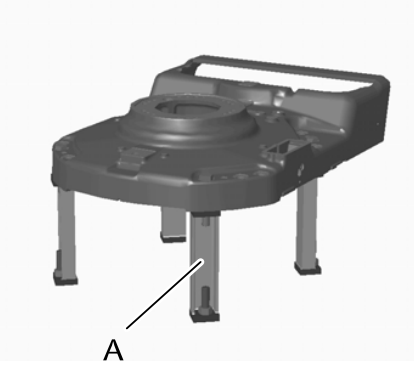

	Action	Note
1	<p>Fit the <i>support, base and gear 1</i> to the base.</p>	<p>Mounting of the support, base and gear 1 is detailed in section Removal, gearbox axis 1 on page 330.</p> <p>The figure shows IRB 760 but is also valid for IRB 460.</p>  <p>xx1000000364</p> <p>A Support base (4 pcs)</p>
2	<p>Make sure the <i>o-ring</i> is seated properly in its groove on the gearbox. Lightly lubricate the o-ring with <i>grease</i>.</p>	<p>Art no. is specified in Required equipment on page 328.</p>

Continues on next page

4 Repair

4.6.1 Replacing the axis 1 gearbox

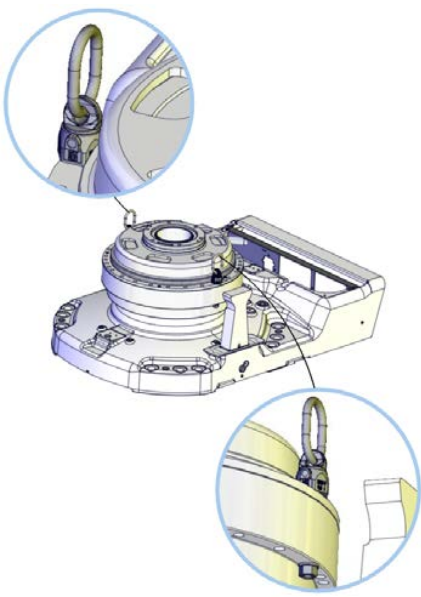

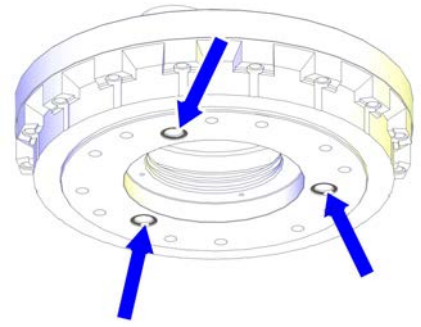
Continued

	Action	Note
3	Fit two <i>lifting eyes</i> on each side of the gearbox. Attach the <i>lifting accessory, base and gear 1</i> and a <i>roundsling</i> , to the gearbox.	Specified in Required equipment on page 328 .  xx1000001395
4	Fit two <i>guide pins</i> in two of the attachment holes in the gearbox, parallel to each other.	Specified in Required equipment on page 328 .
5	 CAUTION The gearbox weighs 108 kg. All lifting accessories used must be sized accordingly!	
6	Check the three o-rings. Replace if damaged!	 xx1300000015
7	Lift gearbox axis 1 onto the guide pins and lower it carefully to its mounting position.	Always use guide pins in pairs!

Continues on next page

4.6.1 Replacing the axis 1 gearbox

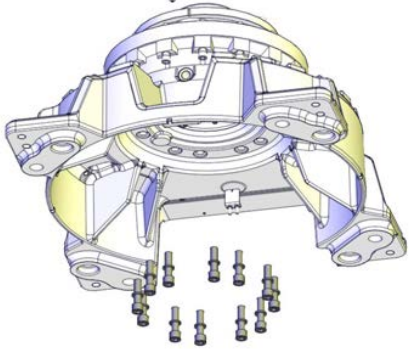
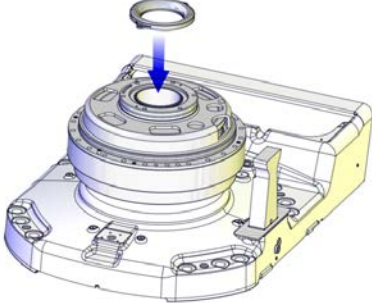
Continued



	Action	Note
8	Secure the gearbox with its <i>attachment screws</i> and washers.	<p>12 pcs, M16x60 quality 12.9 Gleitmo Tightening torque: 300 Nm Reused screws may be used, providing they are lubricated as detailed in section Screw joints on page 394 before fitting.</p>  <p>xx1100000207</p>
9	Refit the cable guide in the center of gearbox 1 with its attachment screws.	<p>The figure shows IRB 760 but is also valid for IRB 460.</p>  <p>xx1000001393</p>
10	<p> CAUTION</p> <p>The base and axis 1 gearbox weighs 130 kg + 108 kg. All lifting accessories used must be sized accordingly!</p>	
11	Lift the robot base and gearbox 1 and remove the base and gear support.	
12	Secure the base to the mounting site.	See Orienting and securing the robot on page 68 .

Continues on next page

4 Repair

4.6.1 Replacing the axis 1 gearbox

Continued

	Action	Note
13	<p>Refit the complete arm system.</p> <p> CAUTION</p> <p>This is a complex task to be performed with utmost care in order to avoid injury or damage!</p>	<p>See Replacing the base, including axis 1 gearbox on page 187.</p>
14	<p>Perform a leak-down test.</p>	<p>See section Performing a leak-down test on page 142.</p>
15	<p>Refill the gearbox with oil.</p>	<p>See Changing oil, axis-1 gearbox on page 124.</p>
16	<p>Recalibrate the robot.</p>	<p>Axis Calibration is described in Calibrating with Axis Calibration method on page 370.</p> <p>General calibration information is included in section Calibration on page 359.</p>
17	<p> DANGER</p> <p>Make sure all safety requirements are met when performing the first test run. See Test run after installation, maintenance, or repair on page 97.</p>	

4.6.2 Replacing the axis 2 gearbox

Location of the axis 2 gearbox

The axis 2 and 3 gearboxes are located on either side of the frame as shown in the figure.

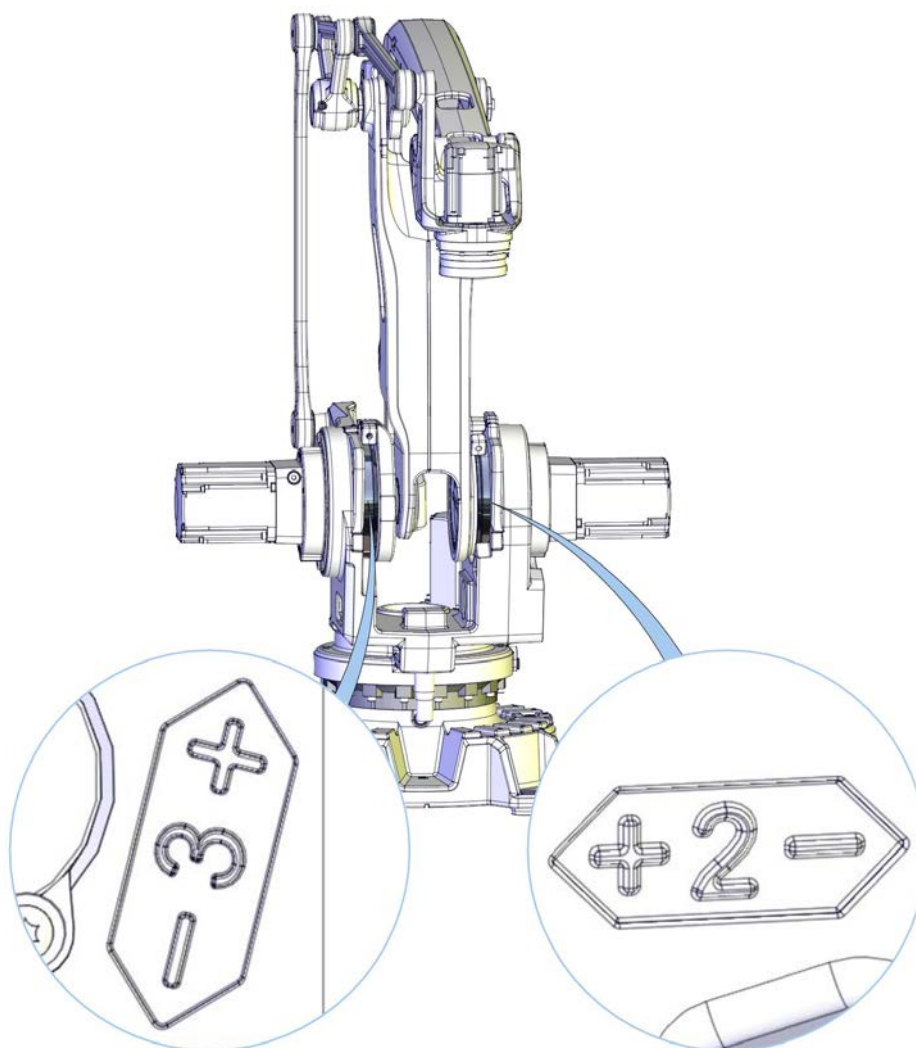

xx110000123

Required equipment

Equipment, etc.	Art.no	Note
Gearbox, axis 2 or axis 3	For spare part no. see: • Spare parts on page 403	
Lock screw M16x90	-	
Screw	M12x60	Fully threaded
Bits extension	-	

Continues on next page

4 Repair

4.6.2 Replacing the axis 2 gearbox

Continued

Equipment, etc.	Art.no	Note
Guide pins	-	M12 Always use guide pins in pairs.
Guide pins	-	M12 Length: 150 mm (the longer one) One shorter than the other. Always use guide pins in pairs.
Pinion crank	-	Used to move the gearbox.
Lifting tool	3HAC025214-001	For lifting gearbox. Includes lifting instruction art. no. 3HAC025523-001.
Rust preventive	3HAC034903-001	Mercasol 3110 Waxcoat
Standard toolkit		Content is defined in section Standard tools on page 398 .
Other tools and procedures may be required. See references to these procedures in the step-by-step instructions below.		These procedures include references to the tools required.

Deciding calibration routine

Decide which calibration routine to be used, based on the information in the table. Depending on which routine is chosen, action might be required prior to beginning the repair work of the robot, see the table.

	Action	Note
1	Decide which calibration routine to use for calibrating the robot. <ul style="list-style-type: none"> Reference calibration. External cable packages (DressPack) and tools can stay fitted on the robot. Fine calibration. All external cable packages (DressPack) and tools must be removed from the robot. 	
	If the robot is to be calibrated with reference calibration: Find previous reference values for the axis or create new reference values. These values are to be used after the repair procedure is completed, for calibration of the robot. If no previous reference values exist, and no new reference values can be created, then reference calibration is not possible.	Follow the instructions given in the reference calibration routine on the FlexPendant to create reference values. Creating new values requires possibility to move the robot. Read more about reference calibration for Axis Calibration in Reference calibration routine on page 371 .
	If the robot is to be calibrated with fine calibration: Remove all external cable packages (DressPack) and tools from the robot.	

Continues on next page

Preparations before removing the axis 2 gearbox

Use this procedure to do the necessary preparations before removing the axis 2 gearbox.

**Note**

Do not replace both gearboxes at the same time, unless the complete arm system is already removed!

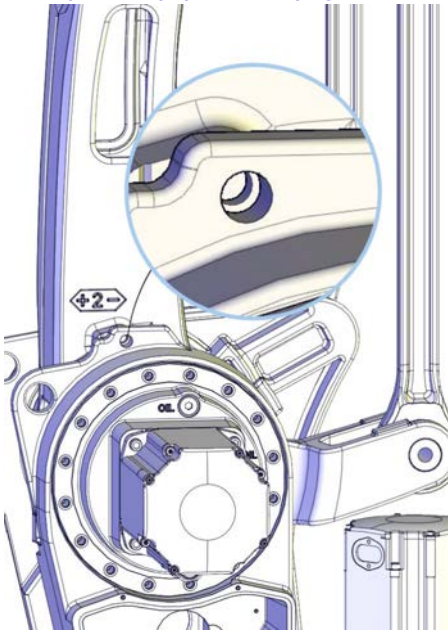
	Action	Note
1	Decide which calibration routine to use, and take actions accordingly prior to beginning the repair procedure.	
2	Drain the gearbox from oil.  Note Time-consuming activity!	Also see
3	Jog axis 2 to 0 degrees and axis 3 to max + degrees.	
4	Insert the <i>lock screw</i> in the lower arm in order to secure axis 2. NOTE! Perform this by hand only!	Dimension of the lock screw is specified in Required equipment on page 337 .  xx1000001179
5	Release the brakes on axes 2 and 3 in order to let the parallel arm rest on the damper.	
6	Apply a roundsling (or similar) securing the parallel rod to the lower arm. This is done in order to lock the parallel arm in position.	

Continues on next page

4 Repair



4.6.2 Replacing the axis 2 gearbox

Continued

	Action	Note
7	 DANGER Turn off all electric power, hydraulic and pneumatic pressure supplies to the robot!	

Removing the axis 2 gearbox

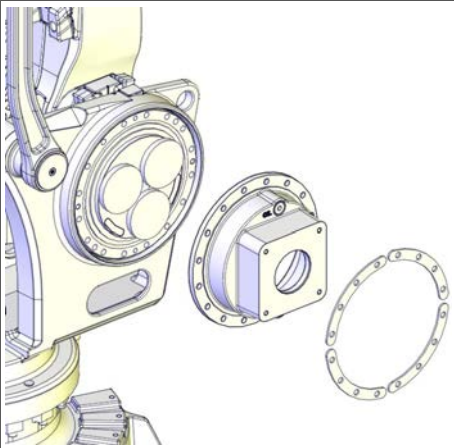
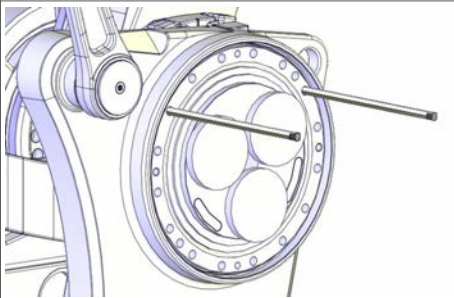
Use this procedure to remove the axis 2 gearbox.

	Action	Note
1	Remove the axis 2 motor. Protect the cables from getting damaged and from getting contaminated with oil spill.	See Replacing motors, axes 2 and 3 on page 309 .
2	Unscrew the attachment screws of the motor flange and lift away the washers and the motor flange.	 <p>xx1100000219</p>
3	Apply two <i>guide pins</i> into two opposite holes in the gearbox.	 <p>xx1100000220</p>  Note Always use guide pins in pairs.
4	 CAUTION The gearbox weighs 51 kg. All lifting accessories used must be sized accordingly!	
5	Fit the <i>lifting tool</i> to the gearbox.	Art. no. is specified in Required equipment on page 337 .

Continues on next page

4.6.2 Replacing the axis 2 gearbox
Continued

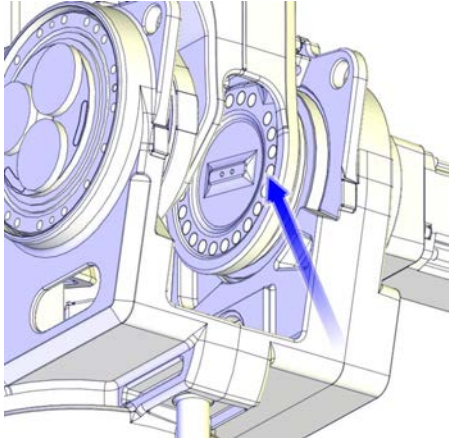
	Action	Note
6	Unscrew the <i>M12 attachment screws</i> securing the gearbox to the lower arm system.	 <p>xx110000221</p>
7	If required, apply two <i>fully threaded M12x60 screws</i> to the holes in the gearbox, in order to press it free.	
8	Lift out the axis 2 gearbox using an overhead crane or similar, with guidance from the fitted guide pins.	

Preparations before refitting the axis 2 gearbox

Use this procedure to do the necessary preparations before removing the axis 2 gearbox.

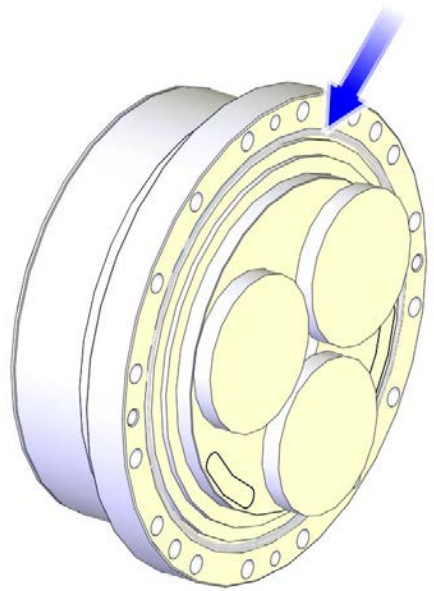
	Action	Note
1	Clean all contact surfaces from residuals of paint and contamination.	
2	Make sure that the <i>o-ring</i> is fitted to the gearbox.	 <p>xx110000223</p>
3	Lightly lubricate the o-ring with grease.	
4	Apply some grease on all contact surfaces.	

Continues on next page

4 Repair

4.6.2 Replacing the axis 2 gearbox

Continued

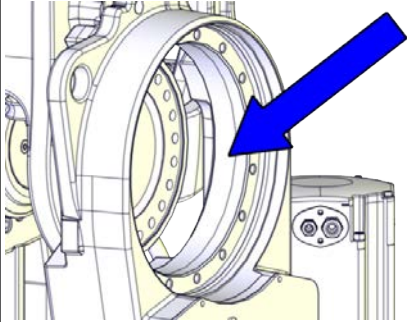
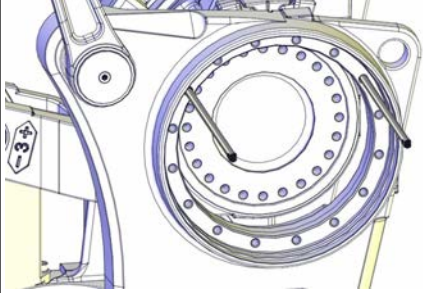
	Action	Note
5	Apply rust preventive on the frame inner surfaces that contact with the gearbox.	 <p>xx220000709</p>
6	Fit two guide pins in opposite holes for the gearbox, in the frame.	 <p>xx110000224</p>
7	Fit two guide pins in opposite holes of the gearbox. One of the guide pins shorter than the other in order to facilitate fitting into the lower arm.	<p>NOTE! The position of the guide pins must be in a way that they are possible to be removed later.</p>

Refitting, the axis 2 gearbox

Use this procedure to refit the axis 2 gearbox.

	Action	Note
1	 CAUTION The gearbox weighs 51 kg. All lifting accessories used must be sized accordingly!	
2	Fit the <i>lifting tool</i> to the gearbox.	Art. no. is specified in <i>Required equipment on page 337</i> .
3	Use an overhead crane or similar and lift the gearbox on to the guide pins.	
4	Slide the gearbox carefully on the guide pins to its mounting position.	
5	Use a crank to move the gearbox in order to find the holes for the attachment screws.	

Continues on next page

4.6.2 Replacing the axis 2 gearbox Continued

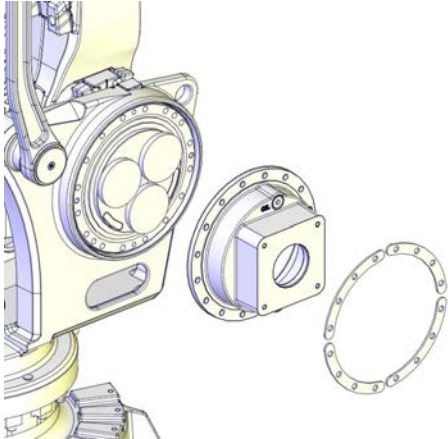
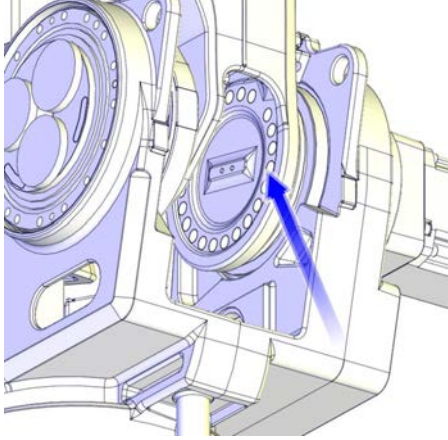
	Action	Note
6	Secure the gearbox and the motor flange to the frame with the <i>attachment screws</i> and <i>washers</i> .	 <p data-bbox="986 757 1098 775">xx110000219</p> <p data-bbox="986 790 1439 882">Attachment screws: M12x60 quality 12.9 gleitmo (16 pcs) Tightening torque: 120 Nm</p>
7	Remove the <i>guide pins</i> and replace them with the remaining attachment screws.	
8	Secure the gearbox to the lower arm system with the <i>attachment screws</i> and <i>washers</i> .	 <p data-bbox="986 1417 1098 1435">xx110000221</p> <p data-bbox="986 1451 1439 1543">Attachment screws: M12x40 quality 12.9 gleitmo (21 pcs) Tightening torque: 120 Nm</p>
9	Remove guide pins in the lower arm.	
10	Secure the rest of the attachment screws.	Tightening torque: 120 Nm

Concluding refitting procedure of the axis 2 gearbox

Use this procedure for the concluding refitting of the axis 2 gearbox.



	Action	Note
1	Wipe the gearbox clean from residual grease.	
2	Refit the <i>motor</i> .	See Replacing motors, axes 2 and 3 on page 309 .

Continues on next page

4 Repair

4.6.2 Replacing the axis 2 gearbox

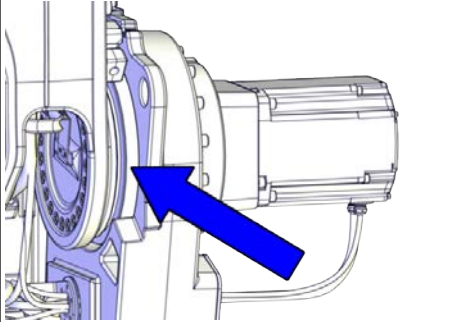
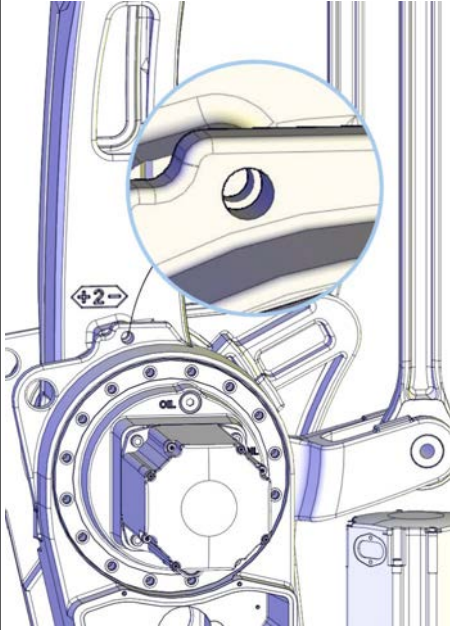
Continued

Action	Note
<p>3 Apply rust preventive on the exposure surfaces of the gearbox.</p>	 <p>xx2200000710</p>
<p>4 Perform a leakdown test.</p>	<p>See Performing a leak-down test on page 142.</p>
<p>5 Refill the gearbox with oil.</p>	<p>Draining, axes 2 and 3 on page 130</p>
<p>6 Remove the <i>lock screw</i>, lower arm.</p>	 <p>xx1000001179</p>
<p>7 Recalibrate the robot.</p>	<p>Axis Calibration is described in Calibrating with Axis Calibration method on page 370. General calibration information is included in section Calibration on page 359.</p>
<p>8  DANGER Make sure all safety requirements are met when performing the first test run. See Test run after installation, maintenance, or repair on page 97.</p>	

4.6.3 Replacing the axis 3 gearbox

Location of the axis 3 gearbox

The axis 2 and 3 gearboxes are located on either side of the frame as shown in the figure.

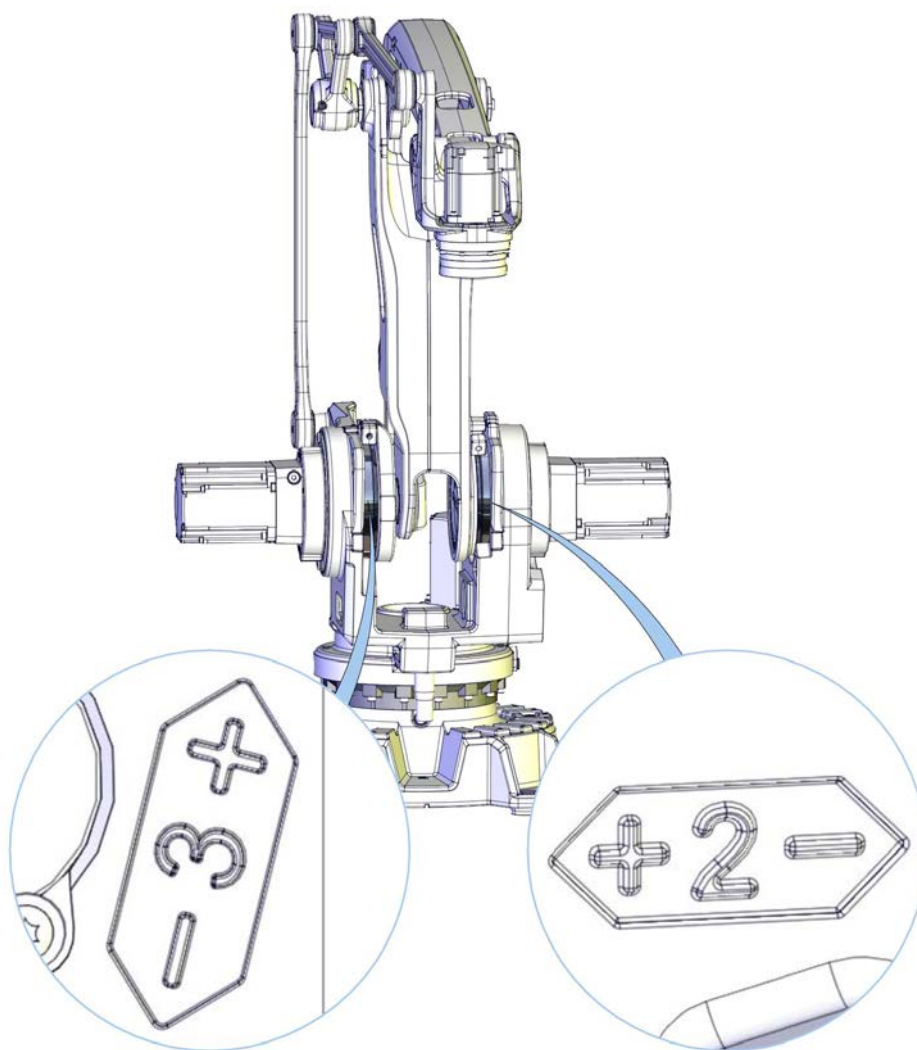

xx110000123

Required equipment

Equipment, etc.	Art.no	Note
Gearbox, axis 2 or axis 3	For spare part no. see: • Spare parts on page 403	
Lock screw M16x90	-	
Screw	M12x60	Fully threaded.
Bits extension	-	

Continues on next page

4 Repair

4.6.3 Replacing the axis 3 gearbox

Continued

Equipment, etc.	Art.no	Note
Guide pins	-	M12 Always use guide pins in pairs.
Guide pins	-	M12 Length: 150 mm (the longer one) One shorter than the other. Always use guide pins in pairs.
Pinion crank	-	Used to move the gearbox.
Lifting tool	3HAC025214-001	For lifting gearbox. Includes lifting instruction art. no. 3HAC025523-001.
Mounting/Demounting tool	3HAC040021-001	
Rust preventive	3HAC034903-001	Mercasol 3110 Waxcoat
Standard toolkit		Content is defined in section Standard tools on page 398 .
Other tools and procedures may be required. See references to these procedures in the step-by-step instructions below.		These procedures include references to the tools required.

Deciding calibration routine

Decide which calibration routine to be used, based on the information in the table. Depending on which routine is chosen, action might be required prior to beginning the repair work of the robot, see the table.

	Action	Note
1	Decide which calibration routine to use for calibrating the robot. <ul style="list-style-type: none"> Reference calibration. External cable packages (DressPack) and tools can stay fitted on the robot. Fine calibration. All external cable packages (DressPack) and tools must be removed from the robot. 	
	<p>If the robot is to be calibrated with reference calibration:</p> <p>Find previous reference values for the axis or create new reference values. These values are to be used after the repair procedure is completed, for calibration of the robot.</p> <p>If no previous reference values exist, and no new reference values can be created, then reference calibration is not possible.</p>	<p>Follow the instructions given in the reference calibration routine on the FlexPendant to create reference values.</p> <p>Creating new values requires possibility to move the robot.</p> <p>Read more about reference calibration for Axis Calibration in Reference calibration routine on page 371.</p>
	<p>If the robot is to be calibrated with fine calibration:</p> <p>Remove all external cable packages (DressPack) and tools from the robot.</p>	

Continues on next page

Preparations before removing the axis 3 gearbox

Use this procedure to do the necessary preparations before removing the axis 3 gearbox.

**Note**

Do not replace both gearboxes at the same time, unless the complete arm system is already removed!

	Action	Note
1	Decide which calibration routine to use, and take actions accordingly prior to beginning the repair procedure.	
2	Drain the gearbox from oil. Note Time-consuming activity!	<i>Draining, axes 2 and 3 on page 130</i>
3	Jog axis 2 to 0 degrees and axis 3 to max + degrees.	
4	Release the brakes on axis 3 in order to let the parallel arm rest on the damper.	
5	Disassemble the lower end of the parallel rod (alternately remove the complete parallel rod). This is done in order to be able to move the parallel arm in the continued removal process.	See <i>Replacing parallel rod on page 272</i> .
6	Jog axis 3 (the parallel arm) to max - degrees.	
7	Release the brakes on axis 3 in order to let the parallel arm rest on the damper.	
8	Jog axis 2 carefully to about +50 degrees. NOTE! Check that the upper arm is moved forwards during jogging.	
9	Let the tilthouse rest against something rigid that can take the weight of the upper arm.	

Removing the axis 3 gearbox

Use this procedure to remove the axis 3 gearbox.



	Action	Note
1	Unscrew as many attachment screws that is possible to remove in the parallel arm at this point.	
2	Jog axis 3 (the parallel arm) to max + degrees.	
3	DANGER Turn off all electric power, hydraulic and pneumatic pressure supplies to the robot!	

Continues on next page

4 Repair

4.6.3 Replacing the axis 3 gearbox

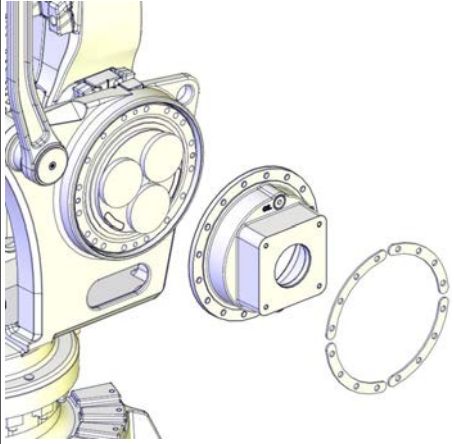
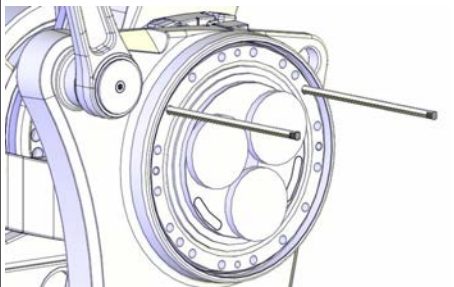
Continued

	Action	Note
4	Unscrew the remaining attachment screws in the parallel arm.	
5	Remove the axis 3 motor.	See Replacing motors, axes 2 and 3 on page 309 .
6	Unscrew the attachment screws of the motor flange and lift away the washers and the motor flange.	 <p>xx110000219</p>
7	Apply two <i>guide pins</i> in opposite holes of the gearbox.	 <p>xx110000220</p> <p> Note Always use guide pins in pairs.</p>
8	 CAUTION The gearbox weighs 51 kg. All lifting accessories used must be sized accordingly!	
9	Fit the <i>lifting tool</i> to the gearbox.	
10	If required, apply two <i>fully threaded</i> M12x60 screws to the holes in the gearbox, in order to press it free.	
11	Lift out the <i>gearbox</i> from the frame using an overhead crane or similar, with guidance from the fitted guide pins.	

Continues on next page

Preparations before refitting the axis 3 gearbox

Use this procedure to do the necessary preparations before removing the axis 3 gearbox.

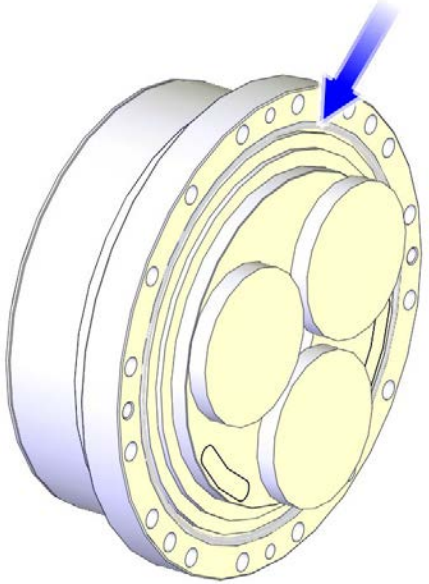
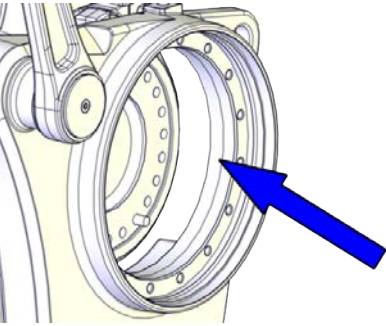
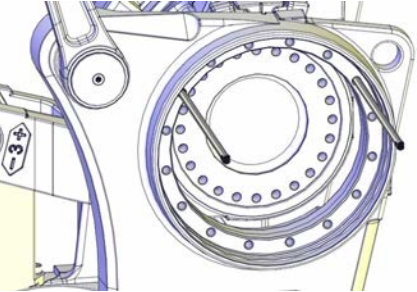
Action	Note	
1	Clean all contact surfaces from residuals of paint and contamination.	
2	Make sure that the <i>o-ring</i> is fitted to the gearbox.	 <p>xx1100000223</p>
3	Lightly lubricate the o-ring with grease.	
4	Apply some grease on all contact surfaces.	
5	Apply rust preventive on the frame inner surfaces that contact with the gearbox.	 <p>xx2200000707</p>
6	Apply two <i>guide pins</i> in opposite holes for the gearbox, in the frame.	 <p>xx1100000224</p>

Continues on next page

4 Repair

4.6.3 Replacing the axis 3 gearbox

Continued

	Action	Note
7	Apply two <i>guide pins</i> in opposite holes of the gearbox. One of the guide pins shorter than the other in order to facilitate fitting into the lower arm.	NOTE! The position of the guide pins must be in a way that they are possible to be removed later.
8	 CAUTION The gearbox weighs 51 kg. All lifting accessories used must be sized accordingly!	
9	Fit the <i>lifting tool</i> to the gearbox.	Art. no. is specified in Required equipment on page 337 .

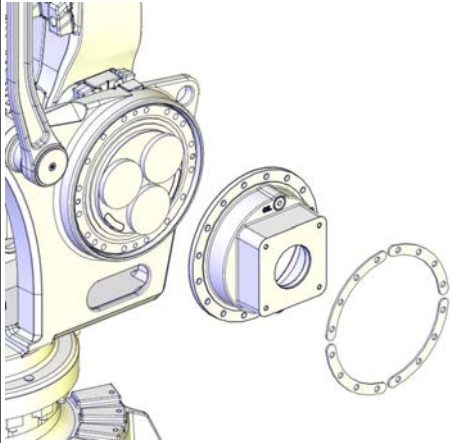

Refitting the axis 3 gearbox

Use this procedure to refit the axis 3 gearbox.

	Action	Note
1	Slide the gearbox carefully on the guide pins to its mounting position, using an overhead crane (or similar)..	
2	Use a crank to move the gearbox in order to find the holes for the attachment screws.	
3	Secure the gearbox and the motor flange to the frame with the <i>attachment screws</i> and <i>washers</i> .	 <p>xx1100000219</p> <p>Attachment screws: M12x60 quality 12.9 gleitmo (16 pcs) Tightening torque: 120 Nm</p>
4	Remove the <i>guide pins</i> and replace them with the remaining attachment screws.	
5	Secure as many attachment screws that is possible to fit in this position, in the parallel arm and secure the axis 3 gearbox.	Attachment screws: M12x40 quality 12.9 gleitmo (21 pcs) Tightening torque: 120 Nm
6	Refit the axis 3 motor.	See Replacing motors, axes 2 and 3 on page 309 .

Continues on next page

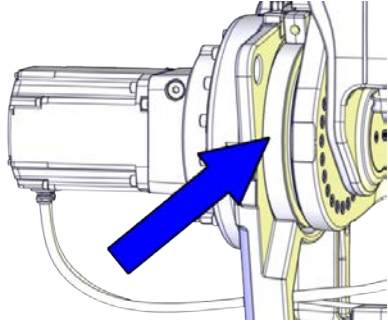
4.6.3 Replacing the axis 3 gearbox Continued

Action	Note
<p>7 Apply rust preventive on the exposure surfaces of the gearbox.</p>	 <p>xx2200000708</p>
<p>8 Jog axes 2 and 3 to a position where the remaining attachment screws can be fitted and secured.</p>	<p>Tightening torque: 120 Nm</p>
<p>9 Jog axis 3 (the parallel arm) very carefully to the position where the parallel rod can be refitted to the parallel arm.</p>	
<p>10 Refit the parallel rod.</p>	<p>See Replacing parallel rod on page 272.</p>
<p>11 Perform a leakdown test.</p>	<p>See Performing a leak-down test on page 142.</p>
<p>12 Refill the gearbox with oil.</p>	<p>Draining, axes 2 and 3 on page 130</p>
<p>13 Recalibrate the robot.</p>	<p>Axis Calibration is described in Calibrating with Axis Calibration method on page 370.</p> <p>General calibration information is included in section Calibration on page 359.</p>
<p>14  DANGER</p> <p>Make sure all safety requirements are met when performing the first test run. See Test run after installation, maintenance, or repair on page 97.</p>	

4 Repair

4.6.4 Replacing gearbox axis 6

4.6.4 Replacing gearbox axis 6

Location of gearbox axis 6

The axis 6 gearbox is located in the center of the wrist as shown in the figure.

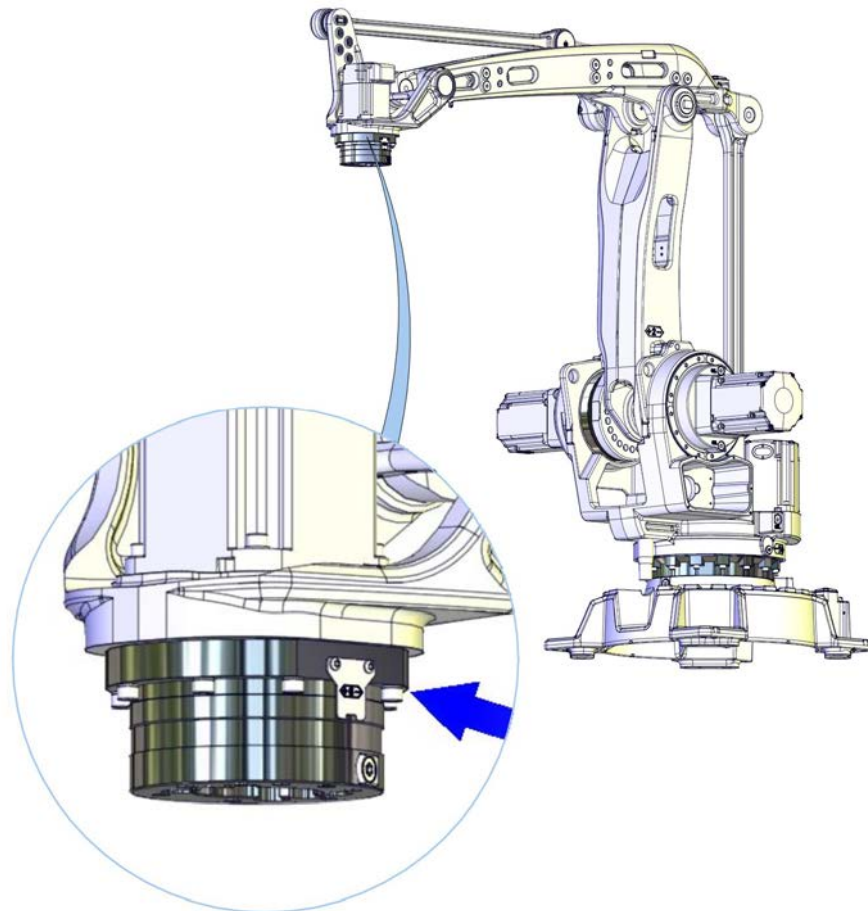

xx110000124

Required equipment

Equipment	Art. no.	Note
Gearbox axis 6	For spare part no. see: <ul style="list-style-type: none">• Spare parts on page 403.	Includes o-ring
Turning disk	For spare part no. see: <ul style="list-style-type: none">• Spare parts on page 403.	

Continues on next page

Equipment	Art. no.	Note
Washers	3HAA1001-172	Not included in gearbox. Replace only if damaged!
O-ring	3HAB3772-58	Located between the gearbox and the turning disk.
Grease	3HAC042536-001	Shell Gadus S2 Used to lubricate the o-ring
Guide pins	-	Always use guide pins in pairs!
Standard toolkit		The content is defined in the section Standard tools on page 398 .
Other tools and procedures may be required. See refer- ences to these procedures in the step-by-step instructions below.		These procedures include references to the tools re- quired.

Deciding calibration routine

Decide which calibration routine to be used, based on the information in the table. Depending on which routine is chosen, action might be required prior to beginning the repair work of the robot, see the table.

	Action	Note
1	Decide which calibration routine to use for calibrating the robot. <ul style="list-style-type: none"> Reference calibration. External cable packages (DressPack) and tools can stay fitted on the robot. Fine calibration. All external cable packages (DressPack) and tools must be removed from the robot. 	
	<p>If the robot is to be calibrated with reference calibration:</p> <p>Find previous reference values for the axis or create new reference values. These values are to be used after the repair procedure is completed, for calibration of the robot.</p> <p>If no previous reference values exist, and no new reference values can be created, then reference calibration is not possible.</p>	<p>Follow the instructions given in the reference calibration routine on the FlexPendant to create reference values.</p> <p>Creating new values requires possibility to move the robot.</p> <p>Read more about reference calibration for Axis Calibration in Reference calibration routine on page 371.</p>
	<p>If the robot is to be calibrated with fine calibration:</p> <p>Remove all external cable packages (DressPack) and tools from the robot.</p>	

Removing gearbox axis 6

Use this procedure to remove gearbox axis 6.

	Action	Note
1	Decide which calibration routine to use, and take actions accordingly prior to beginning the repair procedure.	

Continues on next page

4 Repair

4.6.4 Replacing gearbox axis 6

Continued

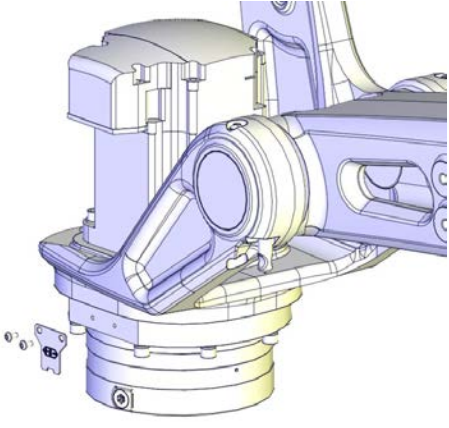
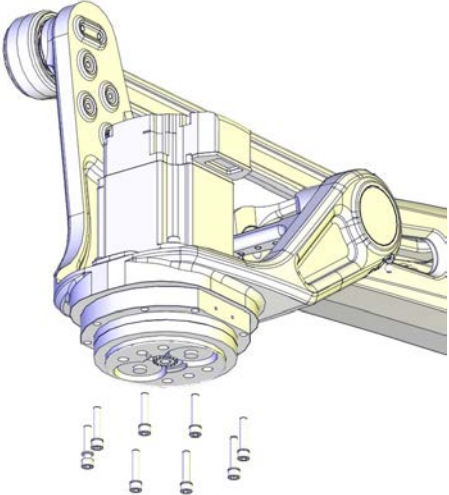
	Action	Note
2	Jog the robot to a position where the tilt-house unit is placed in an appropriate service position.	
3	 DANGER Turn off all: <ul style="list-style-type: none">• electric power supply• hydraulic pressure supply• air pressure supply to the robot, before entering the robot working area.	
4	Drain the <i>oil</i> from the gearbox.	See section <ul style="list-style-type: none">• Changing oil, gearbox axis 6 on page 132
5	Remove the <i>turning disk</i> .	See section <ul style="list-style-type: none">• Replacing the turning disk on page 196
6	Remove the <i>calibration plate axis 6</i> .	 xx110000239
7	Remove the gearbox by unscrewing the <i>attachment screws and washers</i> that secure it.	 xx110000229

Continues on next page

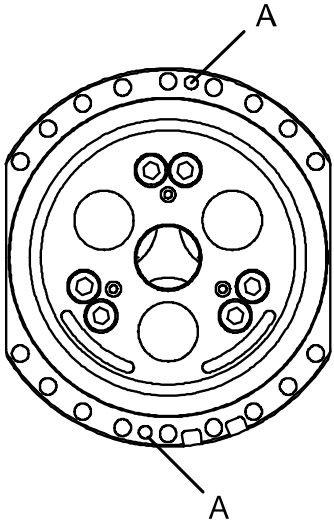
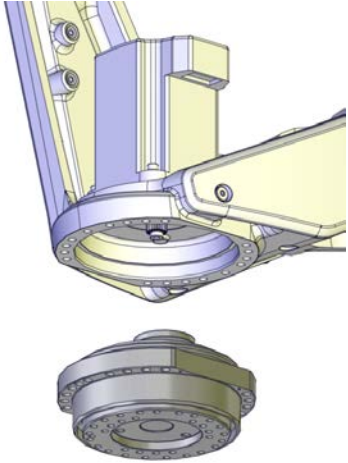
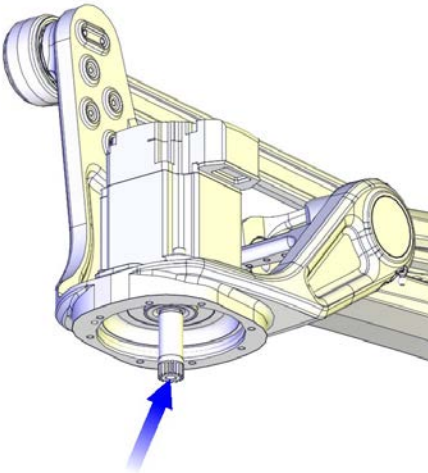
	Action	Note
8	If required apply two M8 screws in the holes shown in the figure, and press out the gearbox.	 <p>xx0200000220</p>
9	Remove <i>gearbox axis 6</i> carefully without damaging pinion or gear.	 <p>xx1000001412</p>
10	Check the pinion. A damaged pinion must be replaced!	 <p>xx1100000240</p>

Continues on next page

4 Repair

4.6.4 Replacing gearbox axis 6

Continued

Refitting gearbox axis 6

Use this procedure to refit gearbox axis 6.

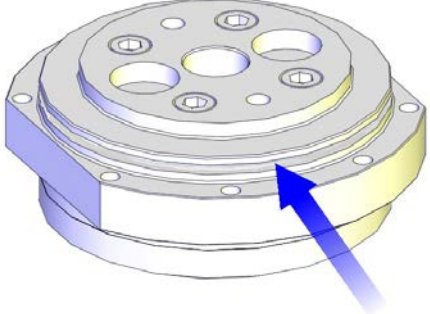
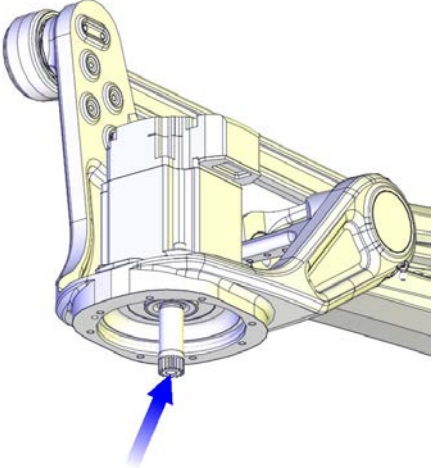
	Action	Note
1	<p> DANGER</p> <p>Turn off all:</p> <ul style="list-style-type: none">• electric power supply• hydraulic pressure supply• air pressure supply <p>to the robot, before entering the robot working area.</p>	
2	<p>Make sure the <i>o-ring</i> is undamaged and fitted to the gearbox. If the o-ring is damaged, replace!</p> <p>Lubricate the o-ring with grease.</p>	<p>For art. no. see: Required equipment on page 352.</p>  <p>xx1100000241</p>
3	<p>Release the brakes of the axis 6 motor manually.</p>	<p>See section</p> <ul style="list-style-type: none">• Manually releasing the brakes on page 60
4	<p>Check that the <i>pinion</i> is undamaged on the axis 6 motor.</p>	 <p>xx1100000240</p>

Continues on next page

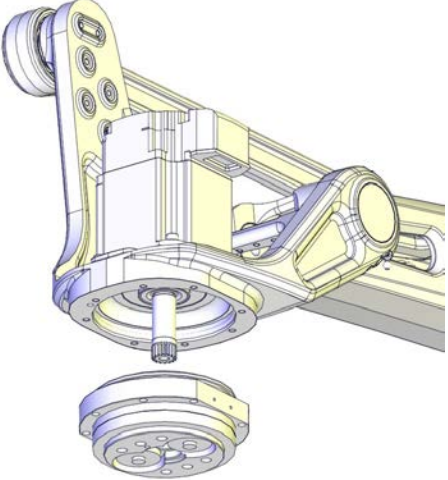
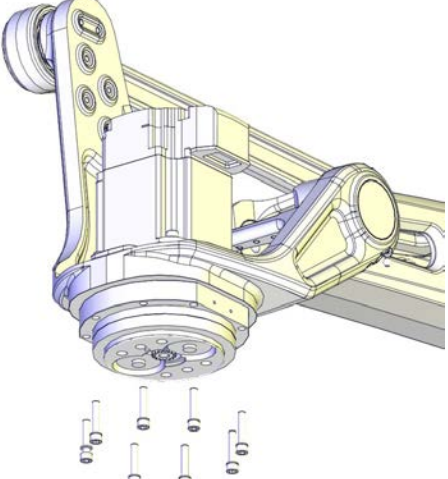

	Action	Note
5	<p>Carefully insert the <i>axis 6 gearbox</i> into the tilthouse, using guide pins. Make sure the gears of the gearbox mate with the pinion of the axis 6 motor.</p> <p> CAUTION</p> <p>Do not damage pinion or gears in the process!</p>	 <p>xx1100000242</p>
6	<p>Secure the gearbox with its <i>attachment screws and washers</i>.</p> <p>Reused screws may be used, providing they are lubricated as detailed in section Screw joints on page 394 before fitting.</p>	 <p>xx1100000229</p> <p>M8x40 quality 12.9 Gleitmo (8 pcs) Tightening torque: 30 Nm</p>
7	<p>Refit the <i>turning disk</i>.</p>	<p>See section</p> <ul style="list-style-type: none"> • Replacing the turning disk on page 196
8	<p>Perform a <i>leak-down test</i>.</p>	<p>See section</p> <ul style="list-style-type: none"> • See section Performing a leak-down test on page 142.
9	<p>Refill the gearbox with <i>oil</i>.</p>	<p>See section</p> <ul style="list-style-type: none"> • Changing oil, gearbox axis 6 on page 132

Continues on next page

4 Repair

4.6.4 Replacing gearbox axis 6

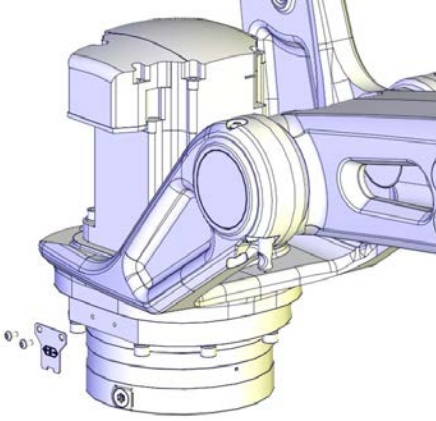
Continued

	Action	Note
10	Refit the <i>calibration plate</i> .	 <p>xx1100000239</p>
11	Re-calibrate the robot.	Axis Calibration is described in Calibrating with Axis Calibration method on page 370 . General calibration information is included in section Calibration on page 359 .
12	 DANGER Make sure all safety requirements are met when performing the first test run. See Test run after installation, maintenance, or repair on page 97 .	

5 Calibration

5.1 Introduction to calibration

5.1.1 Introduction and calibration terminology

Calibration information

This chapter includes general information about the recommended calibration methods and also the detailed procedures for updating the revolution counters, checking the calibration position etc.

Detailed instructions of how to perform Axis Calibration are given on the FlexPendant during the calibration procedure. To prepare calibration with Axis Calibration method, see [Calibrating with Axis Calibration method on page 370](#).

Calibration terminology

Term	Definition
Calibration method	A collective term for several methods that might be available for calibrating the ABB robot. Each method contains calibration routines.
Synchronization position	Known position of the complete robot where the angle of each axis can be checked against visual synchronization marks.
Calibration position	Known position of the complete robot that is used for calibration of the robot.
Standard calibration	A generic term for all calibration methods that aim to move the robot to calibration position.
Fine calibration	A calibration routine that generates a new zero position of the robot.
Reference calibration	<p>A calibration routine that in the first step generates a reference to current zero position of the robot. The same calibration routine can later on be used to recalibrate the robot back to the same position as when the reference was stored.</p> <p>This routine is more flexible compared to fine calibration and is used when tools and process equipment are installed.</p> <p>Requires that a reference is created before being used for recalibrating the robot.</p> <p>Requires that the robot is dressed with the same tools and process equipment during calibration as during creation of the reference values.</p>
Update revolution counter	A calibration routine to make a rough calibration of each manipulator axis.
Synchronization mark	Visual marks on the robot axes. When marks are aligned, the robot is in synchronization position.

5 Calibration

5.1.2 Calibration methods

5.1.2 Calibration methods

Overview

This section specifies the different types of calibration and the calibration methods that are supplied by ABB.

Types of calibration

Type of calibration	Description	Calibration method
Standard calibration	The calibrated robot is positioned at calibration position. Standard calibration data is found on the SMB (serial measurement board) or EIB in the robot. For robots with RobotWare 5.04 or older, the calibration data is delivered in a file, <code>calib.cfg</code> , supplied with the robot at delivery. The file identifies the correct resolver/motor position corresponding to the robot home position.	Axis Calibration

Brief description of calibration methods

Axis Calibration method

Axis Calibration is a standard calibration method for calibration of IRB 460. It is the recommended method in order to achieve proper performance.

The following routines are available for the Axis Calibration method:

- Fine calibration
- Update revolution counters
- Reference calibration

The calibration equipment for Axis Calibration is delivered as a toolkit.

An introduction to the calibration method is given in this manual, see [Calibrating with Axis Calibration method on page 370](#).

The actual instructions of how to perform the calibration procedure and what to do at each step is given on the FlexPendant. You will be guided through the calibration procedure, step by step.

References

Article numbers for the calibration tools are listed in the section [Special tools on page 399](#).

5.1.3 When to calibrate

When to calibrate

The system must be calibrated if any of the following situations occur.

The resolver values are changed

If resolver values are changed, the robot must be re-calibrated using the calibration methods supplied by ABB. Calibrate the robot carefully with standard calibration, according to information in this manual.

The resolver values will change when parts affecting the calibration position are replaced on the robot, for example motors or parts of the transmission.

The revolution counter memory is lost

If the revolution counter memory is lost, the counters must be updated. See [Updating revolution counters on page 364](#). This will occur when:

- The battery is discharged
- A resolver error occurs
- The signal between a resolver and measurement board is interrupted
- A robot axis is moved with the control system disconnected

The revolution counters must also be updated after the robot and controller are connected at the first installation.

The robot is rebuilt

If the robot is rebuilt, for example, after a crash or when the reachability of a robot is changed, it needs to be re-calibrated for new resolver values.

5 Calibration

5.2.1 Synchronization marks and synchronization position for axes

5.2 Synchronization marks and axis movement directions

5.2.1 Synchronization marks and synchronization position for axes

Introduction

This section shows the position of the synchronization marks and the synchronization position for each axis.

Synchronization marks, IRB 460

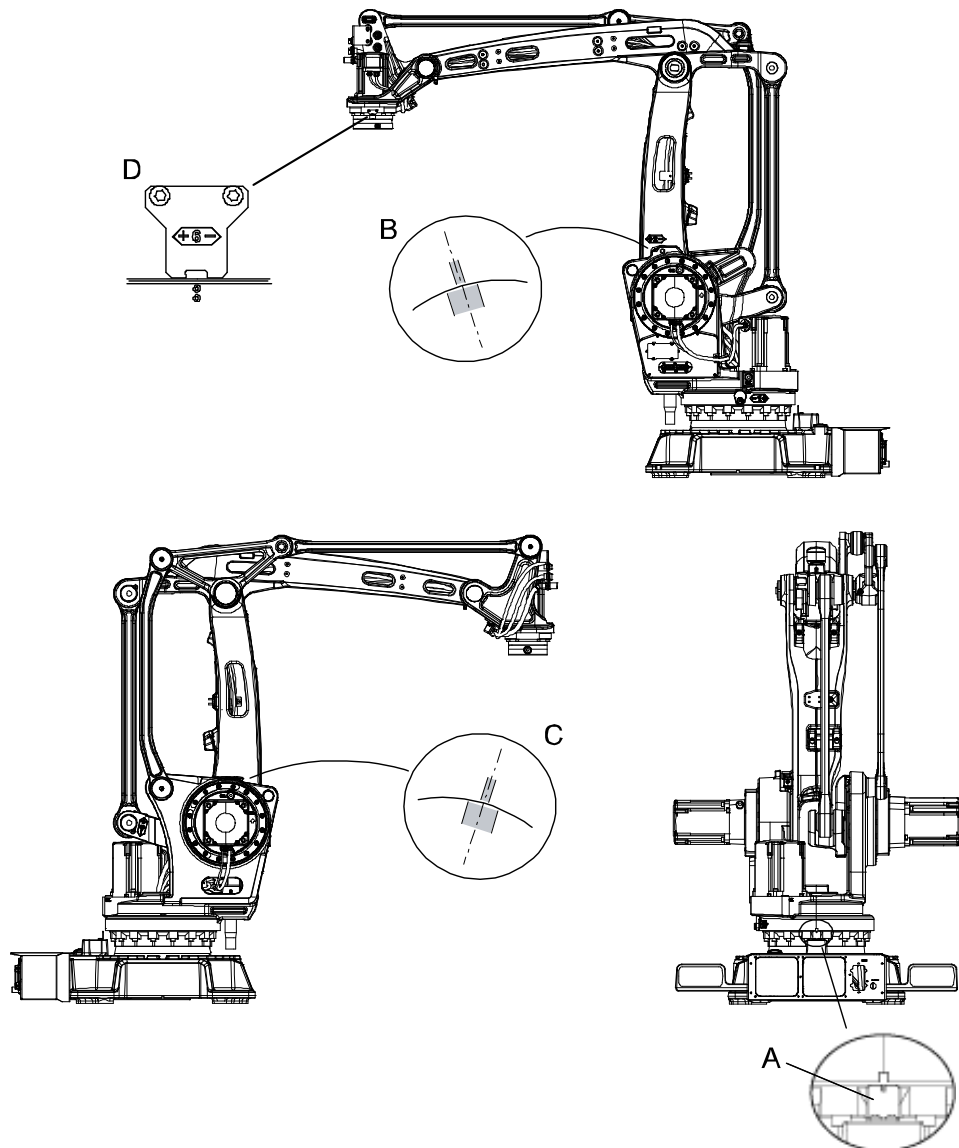

xx1000001433

A	Calibration plate, axis 1
B	Calibration mark, axis 2
C	Calibration mark, axis 3
D	Calibration plate and marking, axis 6

5.2.2 Calibration movement directions for all axes

Overview

When calibrating, the axis must consistently be run towards the calibration position in the same direction in order to avoid position errors caused by backlash in gears and so on. Positive directions are shown in the graphic below.

Calibration service routines will handle the calibration movements automatically and these might be different from the positive directions shown below.

Manual movement directions, 4 axes

Note! The graphic shows an IRB 260. The positive direction is the same for all 4-axis robots

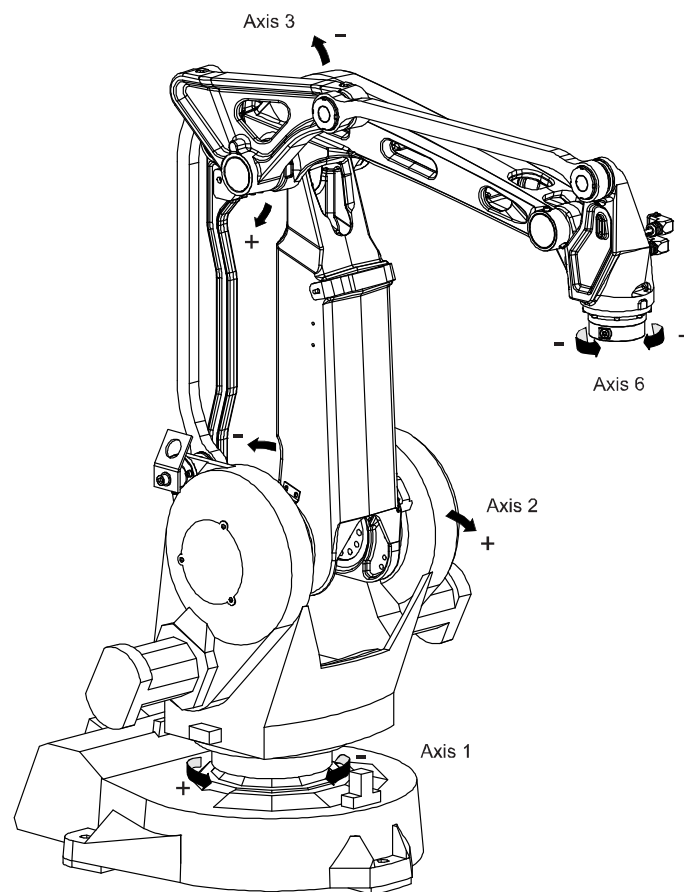

xx0500001927

5 Calibration

5.3.1 Updating revolution counters on IRC5 robots

5.3 Updating revolution counters

5.3.1 Updating revolution counters on IRC5 robots

Introduction

This section describes how to do a rough calibration of each manipulator axis by updating the revolution counter for each axis, using the FlexPendant.

Step 1 - Manually running the manipulator to the synchronization position

Use this procedure to manually run the manipulator to the synchronization position.

	Action	Note
1	Select axis-by-axis motion mode.	
2	Jog the manipulator to align the synchronization marks.	See Synchronization marks and synchronization position for axes on page 362 .
3	When all axes are positioned, update the revolution counter.	Step 2 - Updating the revolution counter with the FlexPendant on page 365 .

Correct calibration position of axis 4 and 6

When jogging the manipulator to synchronization position, it is extremely important to make sure that axes 4 and 6 of the following mentioned manipulators are positioned correctly. The axes can be calibrated at the wrong turn, resulting in an incorrect manipulator calibration.

Make sure the axes are positioned according to the correct calibration values, not only according to the synchronization marks. The correct values are found on a label, located either on the lower arm, underneath the flange plate on the base or on the frame.

At delivery the manipulator is in the correct position. Do NOT rotate axis 4 or 6 at power up before the revolution counters are updated.

If one of the following mentioned axes are rotated one or more turns from its calibration position before updating the revolution counter, the correct calibration position will be lost due to non-integer gear ratio. This affects the following manipulators:

Manipulator variant	Axis 4	Axis 6
IRB 460	No	No

If the synchronization marks seem to be wrong (even if the motor calibration data is correct), try to rotate the axis one turn, update the revolution counter and check the synchronization marks again (try both directions, if needed).

Continues on next page

Step 2 - Updating the revolution counter with the FlexPendant

Use this procedure to update the revolution counter with the FlexPendant (IRC5).

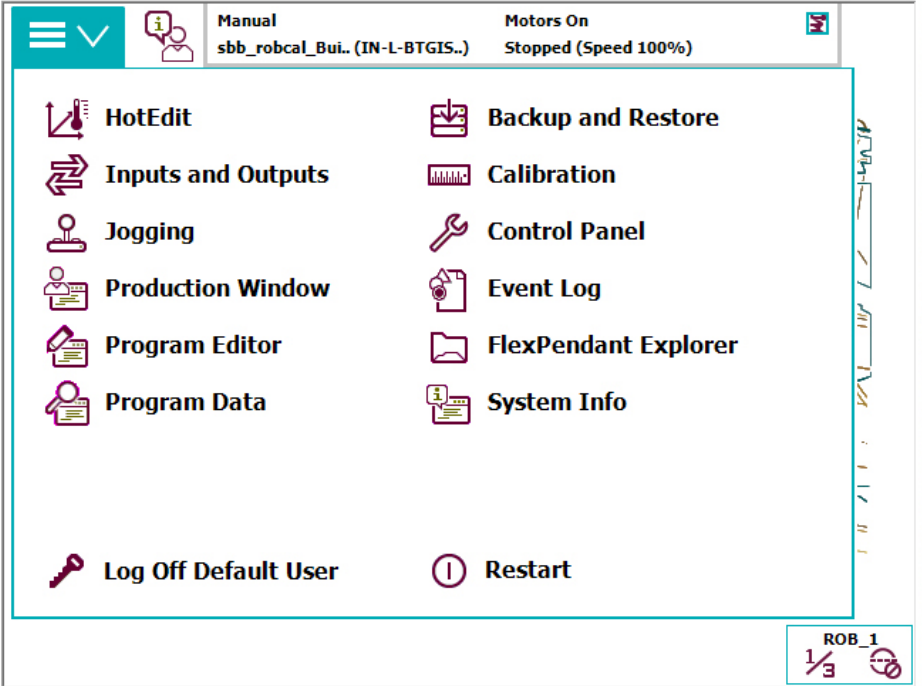
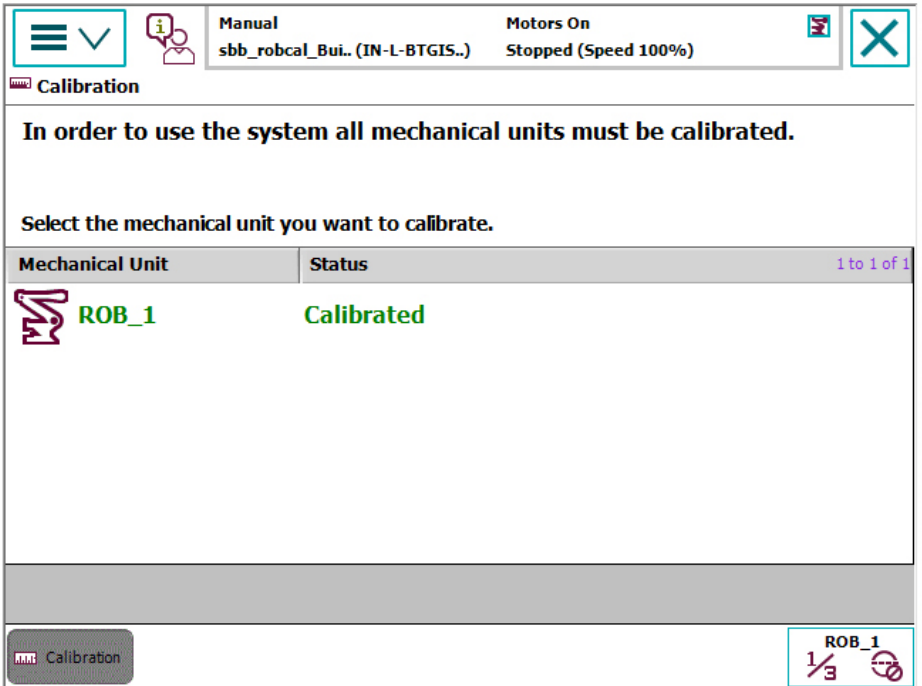
Action	
1	<p>On the ABB menu, tap Calibration.</p>  <p>xx150000942</p>
2	<p>All mechanical units connected to the system are shown with their calibration status. Tap the mechanical unit in question.</p>  <p>xx150000943</p>

Continues on next page

5 Calibration

5.3.1 Updating revolution counters on IRC5 robots

Continued

Action

3 This step is valid for RobotWare 6.02 and later.
Calibration method used at factory for each axis is shown, as well as calibration method used during last field calibration.
Tap **Manual Method (Advanced)**.

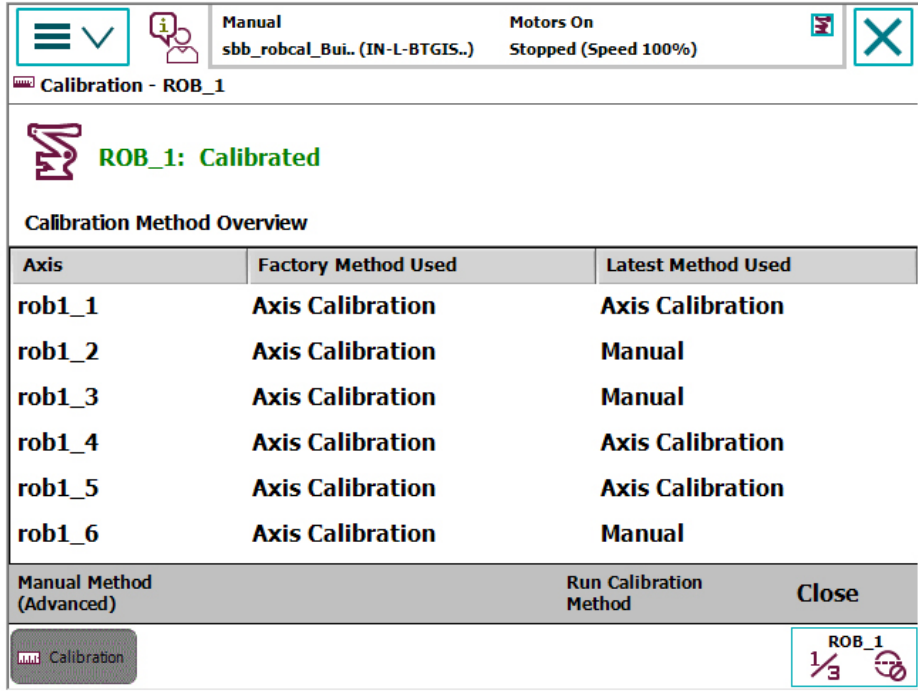

Manual sbb_robcal_Bui.. (IN-L-BTGIS..) Motors On Stopped (Speed 100%)

Calibration - ROB_1

ROB_1: Calibrated

Calibration Method Overview

Axis	Factory Method Used	Latest Method Used
rob1_1	Axis Calibration	Axis Calibration
rob1_2	Axis Calibration	Manual
rob1_3	Axis Calibration	Manual
rob1_4	Axis Calibration	Axis Calibration
rob1_5	Axis Calibration	Axis Calibration
rob1_6	Axis Calibration	Manual

Manual Method (Advanced) Run Calibration Method Close

xx1500000944

4 A screen is displayed, tap **Rev. Counters**.

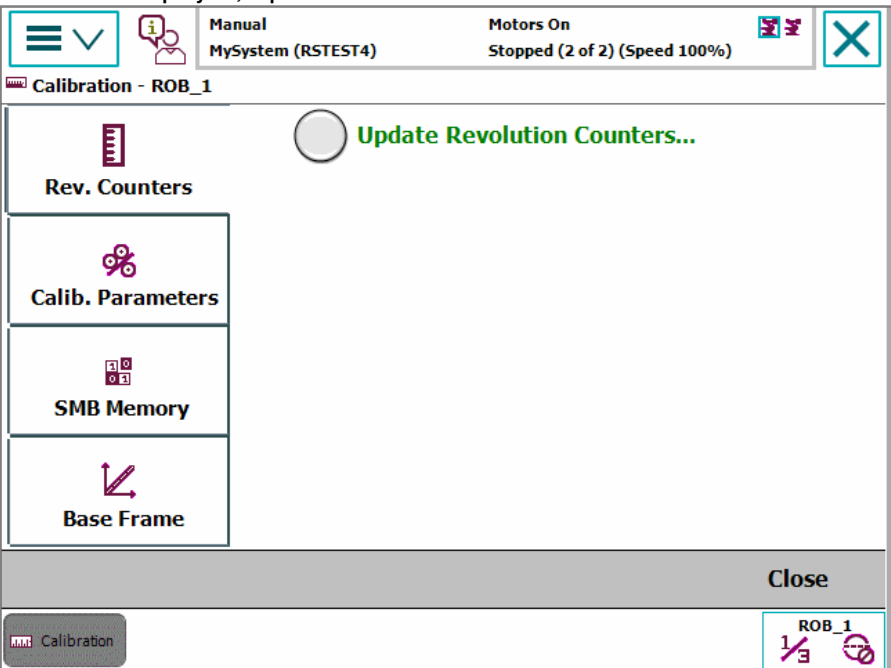

Manual MySystem (RSTEST4) Motors On Stopped (2 of 2) (Speed 100%)

Calibration - ROB_1

Update Revolution Counters...

Rev. Counters

Calib. Parameters

SMB Memory

Base Frame

Close

en0400000771

Continues on next page

	Action
5	<p>Tap Update Revolution Counters...</p> <p>A dialog box is displayed, warning that updating the revolution counters may change programmed robot positions:</p> <ul style="list-style-type: none"> • Tap Yes to update the revolution counters. • Tap No to cancel updating the revolution counters. <p>Tapping Yes displays the axis selection window.</p>
6	<p>Select the axis to have its revolution counter updated by:</p> <ul style="list-style-type: none"> • Ticking in the box to the left • Tapping Select all to update all axes. <p>Then tap Update.</p>
7	<p>A dialog box is displayed, warning that the updating operation cannot be undone:</p> <ul style="list-style-type: none"> • Tap Update to proceed with updating the revolution counters. • Tap Cancel to cancel updating the revolution counters. <p>Tapping Update updates the selected revolution counters and removes the tick from the list of axes.</p>
8	<p> CAUTION</p> <p>If a revolution counter is incorrectly updated, it will cause incorrect manipulator positioning, which in turn may cause damage or injury!</p> <p>Check the synchronization position very carefully after each update. See Checking the synchronization position on page 384.</p>

5 Calibration

5.3.2 Updating revolution counters on OmniCore robots

5.3.2 Updating revolution counters on OmniCore robots

Introduction

This section describes how to do a rough calibration of each manipulator axis by updating the revolution counter for each axis, using the FlexPendant.

Step 1 - Manually running the manipulator to the synchronization position

Use this procedure to manually run the manipulator to the synchronization position.

	Action	Note
1	Select axis-by-axis motion mode.	
2	Jog the manipulator to align the synchronization marks.	See Synchronization marks and synchronization position for axes on page 362 .
3	When all axes are positioned, update the revolution counter.	Step 2 - Updating the revolution counter with the FlexPendant on page 368 .

Correct calibration position of axis 4 and 6

When jogging the manipulator to synchronization position, it is extremely important to make sure that axes 4 and 6 of the following mentioned manipulators are positioned correctly. The axes can be calibrated at the wrong turn, resulting in an incorrect manipulator calibration.

Make sure the axes are positioned according to the correct calibration values, not only according to the synchronization marks. The correct values are found on a label, located either on the lower arm, underneath the flange plate on the base or on the frame.

At delivery the manipulator is in the correct position. Do NOT rotate axis 4 or 6 at power up before the revolution counters are updated.

If one of the following mentioned axes are rotated one or more turns from its calibration position before updating the revolution counter, the correct calibration position will be lost due to non-integer gear ratio. This affects the following manipulators:

Manipulator variant	Axis 4	Axis 6
IRB 460	No	No

If the synchronization marks seem to be wrong (even if the motor calibration data is correct), try to rotate the axis one turn, update the revolution counter and check the synchronization marks again (try both directions, if needed).

Step 2 - Updating the revolution counter with the FlexPendant

Use this procedure to update the revolution counter with the FlexPendant (OmniCore).

	Action
1	On the start screen, tap Calibrate . The calibration summary page for the mechanical unit is displayed.
2	In the Calibration Methods menu, select Revolution Counters .

Continues on next page

	Action
3	In the Selection column select the axes for which revolution counters need to be updated.
4	Tap Update. A dialog box is displayed warning that the updating operation cannot be undone.
5	Tap OK to update the revolution counter.
6	 CAUTION If a revolution counter is incorrectly updated, it will cause incorrect manipulator positioning, which in turn may cause damage or injury! Check the synchronization position very carefully after each update. See Checking the synchronization position on page 384 .

5 Calibration

5.4.1 Description of Axis Calibration

5.4 Calibrating with Axis Calibration method

5.4.1 Description of Axis Calibration

Instructions for Axis Calibration procedure given on the FlexPendant

The actual instructions of how to perform the calibration procedure and what to do at each step is given on the FlexPendant. You will be guided through the calibration procedure, step by step.

This manual contains a brief description of the method, additional information to the information given on the FlexPendant, article number for the tools and images of where to fit the calibration tools on the robot.

Overview of the Axis Calibration procedure

The Axis Calibration procedure applies to all axes, and is performed on one axis at the time. The robot axes are both manually and automatically moved into position, as instructed on the FlexPendant.

A fixed calibration pin/bushing is installed on each robot axis at delivery.

The Axis Calibration procedure described roughly:

- 1 A removable calibration tool is inserted by the operator into a calibration bushing on the axis chosen for calibration, according to instructions on the FlexPendant.



WARNING

Calibrating the robot with Axis Calibration requires special calibration tools from ABB. Using other pins in the calibration bushings may cause severe damage to the robot and/or personnel.



WARNING

The calibration tool must be fully inserted into the calibration bushing, until the steel spring ring snaps into place.

- 2 During the calibration procedure, RobotWare moves the robot axis chosen for calibration so that the calibration tools get into contact. RobotWare records values of the axis position and repeats the coming-in-contact procedure several times to get an exact value of the axis position.



WARNING

Risk of pinching! The contact force for large robots can be up to 150 kg. Keep a safe distance to the robot.

- 3 The axis position is stored in RobotWare with an active choice from the operator.

Continues on next page

Routines in the calibration procedure

The following routines are available in the Axis Calibration procedure, given at the beginning of the procedure on the FlexPendant.

Fine calibration routine

Choose this routine to calibrate the robot when there are no tools, process cabling or equipment fitted to the robot.

Reference calibration routine

Choose this routine to create reference values and to calibrate the robot when the robot is dressed with tools, process cabling or other equipment.



Note

When calibrating the robot with the reference calibration routine, the robot must be dressed with the same tools, process cabling and any other equipment as when the reference values were created.



Note

When using reference calibration with some tools, typically large or flexible tools, oscillations in the robot can cause issues leading to failure of the calibration.

If calibrating the robot with reference calibration there must be reference values created before repair is made to the robot, if values are not already available. Creating new values requires possibility to move the robot. The reference values contain positions of all axes, torque of axes and technical data about the tool installed. A benefit with reference calibration is that the current state of the robot is stored and not the state when the robot left the ABB factory. The reference value will be named according to tool name, date etc.

Follow the instructions given in the reference calibration routine on the FlexPendant to create reference values.

When reference calibration is performed, the robot is restored to the status given by the reference values.

Update revolution counters

Choose this routine to make a rough calibration of each manipulator axis by updating the revolution counter for each axis, using the FlexPendant.

Validation

In the mentioned routines, it is also possible to validate the calibration data.

Position of robot axes

The robot axes should be positioned close to 0 degrees before commencing the calibration program. The axis chosen for calibration is then automatically run by the calibration program to its exact calibration position during the calibration procedure.

It is possible to position some of the other axes in positions different from 0 degrees. Information about which axes are allowed to be jogged is given on the FlexPendant.

Continues on next page

5 Calibration

5.4.1 Description of Axis Calibration

Continued

These axes are marked with **Unrestricted** in the FlexPendant window. Also the following table shows the dependencies between the axes.

Requirements for axis positioning during calibration

	Axis to calibrate					
Required position of axis	Axis 1	Axis 2	Axis 3	Axis 4	Axis 5	Axis 6
Axis 1	-	*	*			*
Axis 2	0	-	0			*
Axis 3	0	0	-			*
Axis 6	*	*	*			-

-	Axis to be calibrated
*	Unrestricted. Axis is allowed to be jogged to other position than 0 degrees.
0	Axis must be put in position 0 degrees.

5.4.2 Calibration tools for Axis Calibration

Calibration tool set

The calibration tools used for Axis Calibration are designed to meet requirements for calibration performance, durability and safety in case of accidental damage.

The calibration tool will eventually break from fatigue after longer period of use and then needs to be replaced. There is no risk for bad calibrations as long as the calibration tool is in one piece.



WARNING

Calibrating the robot with Axis Calibration requires special calibration tools from ABB. Using other pins in the calibration bushings may cause severe damage to the robot and/or personnel.

Equipment, etc.	Article number	Note
Calibration tool box, Axis Calibration	3HAC074119-001	Delivered as a set of calibration tools. Required if Axis Calibration is the valid calibration method for the robot.

Examining the calibration tool

Check prior to usage

Before using the calibration tool, make sure that the tube insert, the plastic protection and the steel spring ring are present.



WARNING

If any part is missing or damaged, the tool must be replaced immediately.

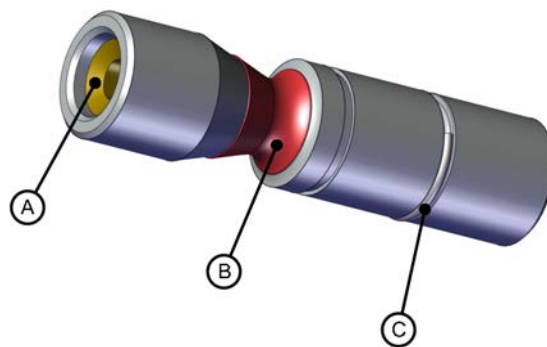

xx1500001914

A	Tube insert
B	Plastic protection
C	Steel spring ring

Continues on next page

5 Calibration

5.4.2 Calibration tools for Axis Calibration

Continued

Periodic check of the calibration tool

If including the calibration tool in a local periodic check system, the following measures should be checked.

- Outer diameter within $\text{Ø}12\text{g}4$ mm, $\text{Ø}8\text{g}4$ mm or $\text{Ø}6\text{g}5$ mm (depending on calibration tool size).
- Straightness within 0.005 mm.

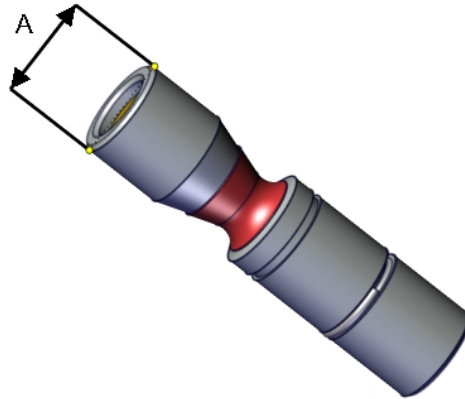

xx1500000951

A	Outer diameter
---	----------------

5.4.3 Installation locations for the calibration tools

Location of fixed calibration items

This section shows how the robot is equipped with items for installation of calibration tools for Axis Calibration (fixed calibration pins and/or bushings). Installed calibration tools are not shown.

A fixed calibration pin and a bushing for the movable calibration tool are located on each axis as follows.

If there is not enough space on an axis to install a fixed calibration pin, the axis is equipped with two bushings instead, for installation of two calibration tools when calibration is carried out. This is shown in the figure.

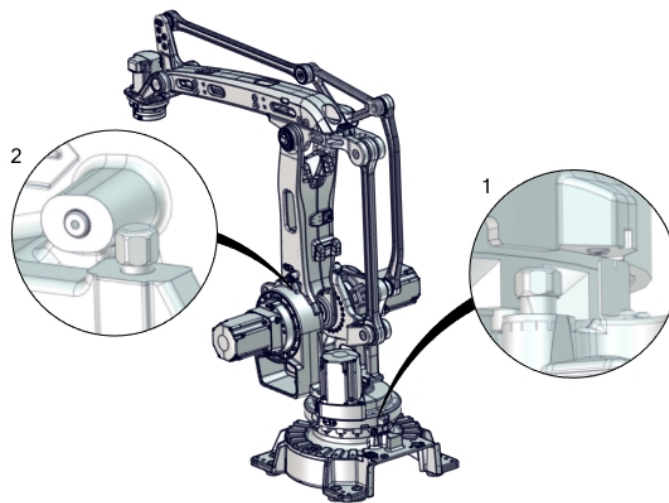

xx170000437

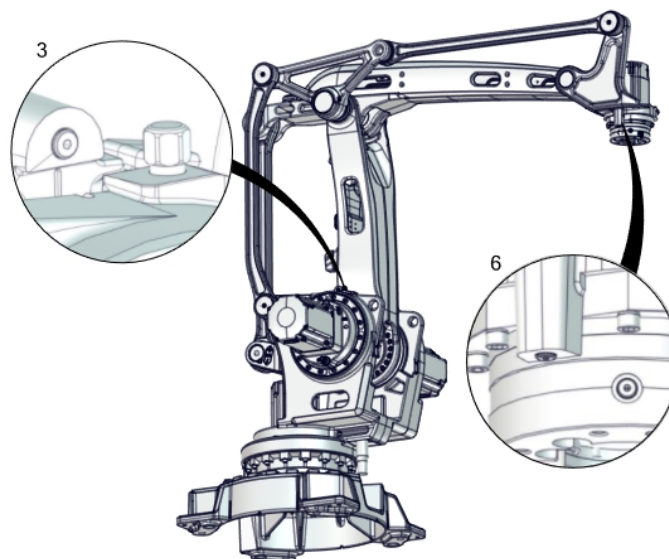

xx170000438

Continues on next page

5 Calibration

5.4.3 Installation locations for the calibration tools

Continued

Spare parts

When calibration is not being performed, a protective cover and an o-ring should always be installed on the fixed calibration pin as well as a protective plug, included a sealing, in the bushing. Replace damaged parts with new.

Spare part	Article number	Note
Protection cover and plug set	3HAC059487-001	Contains replacement calibration pin covers and protective plugs for the bushing.

5.4.4 Axis Calibration - Running the calibration procedure

Required tools

The calibration tools used for Axis Calibration are designed to meet requirements for calibration performance, durability and safety in case of accidental damage.



WARNING

Calibrating the robot with Axis Calibration requires special calibration tools from ABB. Using other pins in the calibration holes may cause severe damage to the robot and/or personnel.

Equipment, etc.	Article number	Note
Calibration tool box, Axis Calibration	3HAC074119-001	Delivered as a set of calibration tools. Required if Axis Calibration is the valid calibration method for the robot.

Required consumables

Consumable	Article number	Note
Clean cloth	-	

Spare parts

Spare part	Article number	Note
Protection cover and plug set	3HAC059487-001	Contains replacement calibration pin covers and protective plugs for the bushing.

Overview of the calibration procedure on the FlexPendant

The actual instructions of how to perform the calibration procedure and what to do at each step is given on the FlexPendant. You will be guided through the calibration procedure, step by step.

Use the following list to learn about the calibration procedure before running the RobotWare program on the FlexPendant. It gives you a brief overview of the calibration procedure.

After the calibration method has been started on the FlexPendant, the following sequence will be run.

- 1 Choose calibration routine. The routines are described in [Routines in the calibration procedure on page 371](#).
- 2 Choose which axis/axes to calibrate.
- 3 The robot moves to synchronization position.
- 4 Validate the synchronization marks.
- 5 The robot moves to preparation position.
- 6 Remove the protective cover from the fixed pin and the protection plug from the bushing, if any, and install the calibration tool.

Continues on next page

5 Calibration

5.4.4 Axis Calibration - Running the calibration procedure



Continued

- 7 The robot performs a measurement sequence by rotating the axis back and forth.
- 8 Remove the calibration tool and reinstall the protective cover on the fixed pin and the protection plug in the bushing, if any.
- 9 The robot moves to verify that the calibration tool is removed.
- 10 Choose whether to save the calibration data or not.

Calibration of the robot is not finished until the calibration data is saved, as last step of the calibration procedure.

Preparation prior to calibration

The calibration procedure is described in the FlexPendant while conducting it.

	Action	Note
1	 DANGER While conducting the calibration, the robot needs to be connected to power. Make sure that the robot's working area is empty, as the robot can make unpredictable movements.	
2	Wipe the calibration tool clean.  Note The calibration method is exact. Dust, dirt or color flakes will affect the calibration value.	Use a clean cloth.

Starting the calibration procedure

Use this procedure to start the Axis Calibration routine on the FlexPendant.

	Action	Note
1	Tap the calibration icon and enter the calibration main page.	
2	All mechanical units connected to the system are shown with their calibration status. Tap the mechanical unit in question.  Note For RobotWare 7, the mechanical unit page is displayed only if there is more than one mechanical unit available.	
3	The calibration method used at ABB factory for each axis is shown, as well as calibration method used for the robot during last field calibration.	The FlexPendant will give all information needed to proceed with Axis Calibration.
4	Valid for RobotWare 6 Tap Call Calibration Method . The software will automatically call for the procedure for the valid calibration method. If not, tap Call Routine and then tap Axis calibration .	

Continues on next page

5.4.4 Axis Calibration - Running the calibration procedure
Continued

	Action	Note
5	Valid for RobotWare 7 Tap Calibration Methods on the right pane and then tap Calibration . The software will automatically call for the procedure for the valid calibration method.	
6	Follow the instructions given on the FlexPendant.	A brief overview of the sequence that will be run on the FlexPendant is given in Overview of the calibration procedure on the FlexPendant on page 377 .

Restarting an interrupted calibration procedure

If the Axis Calibration procedure is interrupted before the calibration is finished, the RobotWare program needs to be started again. Use this procedure to take required action.

Situation	Action
The three-position enabling device on the FlexPendant has been released during robot movement.	Press and hold the three-position enabling device and press Play .
The RobotWare program is terminated with PP to Main .	Remove the calibration tool, if it is installed, and restart the calibration procedure from the beginning. See Starting the calibration procedure . If the calibration tool is in contact the robot axis needs to be jogged in order to release the calibration tool. Jogging the axis in wrong direction will cause the calibration tool to break. Directions of axis movement is shown in Calibration movement directions for all axes on page 363

After calibration

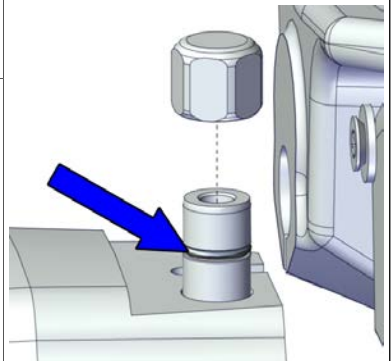
	Action	Note
1	Check the o-ring on the fixed calibration pin. Replace if damaged or missing.	 <p>xx1600002102</p> <p>Protection cover and plug set: 3HAC059487-001.</p>
2	Reinstall the protective cover on the fixed calibration pin on each axis, directly after the axis has been calibrated. Replace the cover with new spare part, if missing or damaged.	

Continues on next page

5 Calibration

5.4.4 Axis Calibration - Running the calibration procedure

Continued

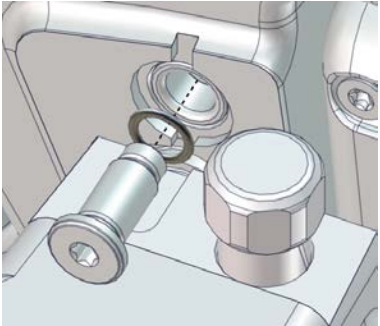
	Action	Note
3	<p>Reinstall the protective plug and sealing in the bushing on each axis, directly after the axis has been calibrated. Ensure that the sealing is not damaged.</p> <p>Replace the plug and the sealing with new spare part, if missing or damaged.</p>	 <p>xx1500000952</p> <p>Protection cover and plug set: 3HAC059487-001.</p>

5.4.5 Reference calibration

Brief introduction to Reference Calibration

Reference calibration is a faster method compared to Fine calibration, as it refers to a previously made calibration.

- 1 Create a backup of the current robot system.
- 2 Check that the active calibration offset values corresponds to the values on the calibration label (located on the lower arm or the base).
- 3 Jog the manipulator so that all axes are in zero position (ex use `MoveAbsJ` instruction). Check that all axis scales are aligned with calibration marks.
- 4 If the scales differ from calibration marks it might depend on wrong turns of the revolution counters. Make a marker line on the corresponding axis to be able to validate the result of the calibration. If more than one motor revolutions are wrong, the calibration will fail.
- 5 Use a verification position. This is especially recommended if all axes were not aligned with the synchronization marks (step 3). Reuse an existing position that is suitable and accurate so it can be used to validate the repair. Use a position where a deviation in axis calibration gives a big deviation in positioning. Note! Check the position after each repair in one axis.
- 6 Use Reference calibration to save reference values for all axes that is to be replaced. Make sure that the values are saved in RobotStudio or FTP program. The files are located in "Active system folder name/HOME/RefCalibFiles".
- 7 Perform the repair.
- 8 Make sure that the tooling and process equipment are the same as when creating the reference. Use Reference calibration to update the system with new calibration offset value for the repaired axis.
- 9 Check the position against the verification position (step 5).
- 10 Proceed with the repair of the next axis, if necessary, and repeat (step 8-9) for every axis.
- 11 (For system containing SafeMove or EPS) Download new calibration values to SafeMove. Use Visual SafeMove in RobotStudio.
- 12 (For system containing SafeMove or EPS) Synchronize SafeMove to activate SafeMove.
- 13 Perform test run.
- 14 Update the calibration label with new resolver values (calibration values).

Manual tuning of calibration offset

Manual tuning of calibration offset is normally not needed, but can be useful in some situations. The requirement to do manual tuning is that there is a known accurate position, that worked accurately before the repair (step 5, see [Brief introduction to Reference Calibration on page 381](#)).

Example "Adjust axis 4":

- 1 Create a backup.

Continues on next page

5 Calibration

5.4.5 Reference calibration

Continued

- 2 Run the manipulator to the verification position. (The manipulator position is now deviating from the verification position.)
- 3 Read and note current axis 4 value in degrees (example: 96.3 degrees).
- 4 Manually jog, only axis 4, so that the manipulator is correctly positioned to the verification position.
- 5 Read and note current axis 4 value in degrees (example: 94.2 degrees).
- 6 Move the manipulator to its calibration position.
- 7 Calculate the angle difference (ie $96.3 - 94.2 = 2.1$ degrees).
- 8 Manually jog axis 4 the calculated angle difference (-2.1). NOTE! The direction +/- shall be the same direction as the direction used when axis 4 was manually jogged to coincide with the verification process. In the example -2.1 degrees.
- 9 Make a new manual fine calibration of axis 4 with axis in -2.1 degrees position.
- 10 Check again against the verification position.
- 11 Repeat the manual tuning if needed.
- 12 Create a new reference if the intention is to use the reference in the future.

5.5 Verifying the calibration

Introduction

Always verify the results after calibrating *any* robot axis to verify that all calibration positions are correct.

Verifying the calibration

Use this procedure to verify the calibration result.

	Action	Note
1	Run the calibration home position program twice. Do not change the position of the robot axes after running the program!	See Checking the synchronization position on page 384 .
2	Adjust the <i>synchronization marks</i> when the calibration is done, if necessary.	This is detailed in section Synchronization marks and synchronization position for axes on page 362 .
3	Write down the values on a new label and stick it on top of the calibration label. The label is located on the lower arm.	

5 Calibration

5.6 Checking the synchronization position

5.6 Checking the synchronization position

Introduction

Check the synchronization position of the robot before beginning any programming of the robot system. This may be done:

- Using a `MoveAbsJ` instruction with argument zero on all axes.
- Using the **Jogging** window on the FlexPendant. Using the **Jog** window on the FlexPendant.

Using a `MoveAbsJ` instruction

Use this procedure to create a program that runs all the robot axes to their synchronization position.

	Action	Note
1	On ABB menu tap Program editor .	
2	Create a new program.	
3	Use MoveAbsJ in the Motion&Proc menu.	
4	Create the following program: <pre>MoveAbsJ [[0,0,0,0,0,0], [9E9,9E9,9E9,9E9,9E9,9E9]] \NoEOffs, v1000, fine, tool0</pre>	
5	Run the program in manual mode.	
6	Check that the synchronization marks for the axes align correctly. If they do not, update the revolution counters.	See Synchronization marks and synchronization position for axes on page 362 and Updating revolution counters on page 364 .

Using the jogging window

Use this procedure to jog the robot to the synchronization position of all axes.

	Action	Note
1	On the ABB menu, tap Jogging .	
2	Tap Motion mode to select group of axes to jog.	
3	Tap to select the axis to jog, axis 1, 2, or 3.	
4	Manually run the robots axes to a position where the axis position value read on the FlexPendant, is equal to zero.	
5	Check that the synchronization marks for the axes align correctly. If they do not, update the revolution counters.	See Synchronization marks and synchronization position for axes on page 362 and Updating revolution counters on page 364 .

Continues on next page

Using a MoveAbsJ instruction

Use this procedure to create a program that runs all the robot axes to their synchronization position.

	Action	Note
1	Tap Code .	
2	Create a new program.	
3	Use MoveAbsJ in the Add Instruction menu.	
4	Create the following program: <pre>MoveAbsJ [[0,0,0,0,0,0], [9E9,9E9,9E9,9E9,9E9,9E9]] \NoEOfs, v1000, fine, tool0</pre>	
5	Run the program in manual mode.	
6	Check that the synchronization marks for the axes align correctly. If they do not, update the revolution counters.	See Synchronization marks and synchronization position for axes on page 362 and Updating revolution counters on page 364 .

Using the jogging window

Use this procedure to jog the robot to the synchronization position of all axes.

	Action	Note
1	Tap Jog .	
2	From the Mechanical unit list select a mechanical unit.	
3	From the Motion mode section, select an axis-set that need to be jogged. For example, to jog axis 2, select the axis set Axis 1-3 .	
4	Follow the screen instruction on joystick movements to understand the direction of the axis that you want to move and move the joystick.	
5	Manually run the robots axes to a position where the axis position value read on the FlexPendant, is equal to zero.	
6	Check that the synchronization marks for the axes align correctly. If they do not, update the revolution counters.	See Synchronization marks and synchronization position for axes on page 362 and Updating revolution counters on page 364 .

This page is intentionally left blank

6 Decommissioning

6.1 Introduction to decommissioning

Introduction

This section contains information to consider when taking a product, robot or controller, out of operation.

It deals with how to handle potentially dangerous components and potentially hazardous materials.



Note

The decommissioning process shall be preceded by a risk assessment.

Disposal of materials used in the robot

All used grease/oils and dead batteries **must** be disposed of in accordance with the current legislation of the country in which the robot and the control unit are installed.

If the robot or the control unit is partially or completely disposed of, the various parts **must** be grouped together according to their nature (which is all iron together and all plastic together), and disposed of accordingly. These parts **must** also be disposed of in accordance with the current legislation of the country in which the robot and control unit are installed.

See also [Environmental information on page 388](#).

Transportation

Prepare the robot or parts before transport, this to avoid hazards.

6 Decommissioning

6.2 Environmental information

6.2 Environmental information

Introduction

ABB robots contain components in different materials. During decommissioning, all materials should be dismantled, recycled, or reused responsibly, according to the relevant laws and industrial standards. Robots or parts that can be reused or upcycled helps to reduce the usage of natural resources.

Symbol

The following symbol indicates that the product must not be disposed of as common garbage. Handle each product according to local regulations for the respective content (see table below).

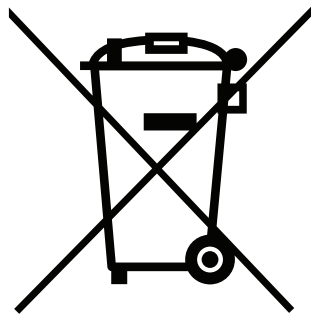

xx1800000058

Materials used in the product

The table specifies some of the materials in the product and their respective use throughout the product.

Dispose components properly according to local regulations to prevent health or environmental hazards.

Material	Example application
Aluminium	Covers, synchronization brackets
Batteries, Lithium	Serial measurement board
Cast iron/nodular iron	Base, lower arm, upper arm
Copper	Cables, motors
Neodymium	Brakes, motors
Oil, grease	Gearboxes
Plastic/rubber	Cables, connectors, drive belts, and so on.
Steel	Gears, screws, base frame, and so on.

Continues on next page

China RoHS symbol

The following symbol shows the information to hazardous substances and the environmental protection use period of IRB 460 according to "Management Methods for the Restriction of the Use of Hazardous Substances in Electrical and Electronic Products (SJ/T 11364-2014)".



xx190000803

Green symbol with "e" in it: The product does not contain any hazardous substances exceeding concentration limits and is a green environmentally friendly product which can be recycled.

Oil and grease

Where possible, arrange for oil and grease to be recycled. Dispose of via an authorized person/contractor in accordance with local regulations. Do not dispose of oil and grease near lakes, ponds, ditches, down drains, or onto soil. Incineration must be carried out under controlled conditions in accordance with local regulations.

Also note that:

- Spills can form a film on water surfaces causing damage to organisms. Oxygen transfer could also be impaired.
- Spillage can penetrate the soil causing ground water contamination.

6 Decommissioning

6.3 Scrapping of robot

6.3 Scrapping of robot



Note

The decommissioning process shall be preceded by a risk assessment.

Important when scrapping the robot



DANGER

The risk assessment should consider hazards arising in the decommissioning, such as, but not limited to:

- Always remove all batteries. If a battery is exposed to heat, for example from a blow torch, it will explode.
- Always remove all oil/grease in gearboxes. If exposed to heat, for example from a blow torch, the oil/grease will catch fire.
- When motors are removed from the robot, the robot will collapse if it is not properly supported before the motor is removed.
- A used robot does not have the same performance as on delivery. Springs, brakes, bearings, and other parts might be worn or broken.

7 Reference information

7.1 Introduction

General

This chapter includes general information, complementing the more specific information in the different procedures in the manual.

7 Reference information

7.2 Applicable standards

7.2 Applicable standards

General

The product is compliant with ISO 10218-1:2011, *Robots for industrial environments - Safety requirements - Part 1 Robots*, and applicable parts in the normative references, as referred to from ISO 10218-1:2011. In case of deviation from ISO 10218-1:2011, these are listed in the declaration of incorporation. The declaration of incorporation is part of the delivery.

Robot standards

Standard	Description
ISO 9283	Manipulating industrial robots – Performance criteria and related test methods
ISO 9787	Robots and robotic devices – Coordinate systems and motion nomenclatures
ISO 9946	Manipulating industrial robots – Presentation of characteristics

Other standards used in design

Standard	Description
IEC 60204-1	Safety of machinery - Electrical equipment of machines - Part 1: General requirements, normative reference from ISO 10218-1
IEC 61000-6-2	Electromagnetic compatibility (EMC) – Part 6-2: Generic standards – Immunity standard for industrial environments
IEC 61000-6-4	Electromagnetic compatibility (EMC) – Part 6-4: Generic standards – Emission standard for industrial environments
ISO 13849-1:2006	Safety of machinery - Safety related parts of control systems - Part 1: General principles for design, normative reference from ISO 10218-1

Region specific standards and regulations

Standard	Description
ANSI/RIA R15.06	Safety requirements for industrial robots and robot systems
ANSI/UL 1740	Safety standard for robots and robotic equipment
CAN/CSA Z 434-03	Industrial robots and robot Systems - General safety requirements
EN ISO 10218-1	Robots and robotic devices — Safety requirements for industrial robots — Part 1: Robots

7.3 Unit conversion

Converter table

Use the following table to convert units used in this manual.

Quantity	Units		
Length	1 m	3.28 ft.	39.37 in
Weight	1 kg	2.21 lb.	
Weight	1 g	0.035 ounces	
Pressure	1 bar	100 kPa	14.5 psi
Force	1 N	0.225 lbf	
Moment	1 Nm	0.738 lbf-ft	
Volume	1 L	0.264 US gal	

7 Reference information

7.4 Screw joints

7.4 Screw joints

General

This section describes how to tighten the various types of screw joints on ABB robots.

The instructions and torque values are valid for screw joints comprised of metallic materials and do *not* apply to soft or brittle materials.

UNBRAKO screws

UNBRAKO is a special type of screw recommended by ABB for certain screw joints. It features special surface treatment (Gleitmo as described below) and is extremely resistant to fatigue.

Whenever used, this is specified in the instructions, and in such cases, *no other type of replacement screw* is allowed. Using other types of screws will void any warranty and may potentially cause serious damage or injury.

Gleitmo treated screws

Gleitmo is a special surface treatment to reduce the friction when tightening the screw joint. It is recommended by ABB for M6-M20 screw joints. Screws treated with Gleitmo may be reused 3-4 times before the coating disappears. After this the screw must be discarded and replaced with a new one.

When handling screws treated with Gleitmo, protective gloves of nitrile rubber type should be used.

Generally, screws are lubricated with *Gleitmo 603* mixed with *Geomet 500* or *Geomet 702* in proportion 1:3. *Geomet* thickness varies according to screw dimensions, refer to the following.

Dimension	Lubricant	Geomet thickness
M6-M20 (any length except M20x60)	<i>Gleitmo 603 + Geomet 500</i>	3-5 µm
M6-M20 (any length except M20x60)	<i>Gleitmo 603 + Geomet 720</i>	3-5 µm
M20x60	<i>Gleitmo 603 + Geomet 500</i>	8-12 µm
M20x60	<i>Gleitmo 603 + Geomet 720</i>	6-10 µm

Screws lubricated in other ways

Screws lubricated with Molykote 1000 or Molykote P1900 should *only* be used when specified in the repair, maintenance or installation procedure descriptions.

In such cases, proceed as follows:

- 1 Apply lubricant to the screw thread.
- 2 Apply lubricant between the plain washer and screw head.
- 3 Screw dimensions of M8 or larger must be tightened with a torque wrench. Screw dimensions of M6 or smaller may be tightened without a torque wrench *if* this is done by trained and qualified personnel.

Continues on next page

Lubricant	Article number
Molykote 1000 (molybdenum disulphide grease)	3HAC042472-001
Molykote P1900 (molybdenum disulphide grease)	3HAC070875-001

Tightening torque

Before tightening any screw, note the following:

- Determine whether a **standard** tightening torque or **special** torque is to be applied. The **standard torques** are specified in the following tables. Any **special torques** are specified in the repair, maintenance or installation procedure descriptions. **Any special torque specified overrides the standard torque!**
- Use the *correct tightening torque* for each type of screw joint.
- Only use *correctly calibrated* torque keys.
- *Always tighten the joint by hand*, and never use pneumatic tools.
- Use the *correct tightening technique*, that is *do not* jerk. Tighten the screw in a slow, flowing motion.
- Maximum allowed total deviation from the specified value is **10%!**

Tightening torque for oil-lubricated screws with slotted or cross-recess head screws

The following table specifies the recommended standard tightening torque for *oil-lubricated screws with slotted or cross-recess head screws*.



Note

A special torque specified in the repair, maintenance or installation procedure overrides the standard torque.

Tightening torque for oil-lubricated screws with allen head screws

The following table specifies the recommended standard tightening torque for *oil-lubricated screws with allen head screws*.



Note

A special torque specified in the repair, maintenance or installation procedure overrides the standard torque.

Dimension	Tightening torque (Nm)	Tightening torque (Nm)	Tightening torque (Nm)
	Class 8.8, oil-lubricated	Class 10.9, oil-lubricated	Class 12.9, oil-lubricated
M5	6	-	-
M6	10	-	-
M8	24	34	40
M10	47	67	80
M12	82	115	140
M16	200	290	340
M20	400	560	670

Continues on next page

7 Reference information

7.4 Screw joints

Continued

Dimension	Tightening torque (Nm) Class 8.8, oil-lubricated	Tightening torque (Nm) Class 10.9, oil-lubricated	Tightening torque (Nm) Class 12.9, oil-lubricated
M24	680	960	1150

Tightening torque for lubricated screws (Molykote, Gleitmo or equivalent) with allen head screws
The following table specifies the recommended standard tightening torque for *screws lubricated with Molykote 1000, Gleitmo 603 or equivalent with allen head screws.*



Note

A special torque specified in the repair, maintenance or installation procedure overrides the standard torque.

Dimension	Tightening torque (Nm) Class 10.9, lubricated ⁱ	Tightening torque (Nm) Class 12.9, lubricated ⁱ
M5		8
M6		14
M8	28	35
M10	55	70
M12	96	120
M16	235	300
M20	460	550
M24	790	950

ⁱ Lubricated with Molykote 1000, Gleitmo 603 or equivalent

7.5 Weight specifications

Definition

In installation, repair, and maintenance procedures, weights of the components handled are sometimes specified. All components exceeding 22 kg (50 lbs) are highlighted in this way.

To avoid injury, ABB recommends the use of a lifting accessory when handling components with a weight exceeding 22 kg. A wide range of lifting accessories and devices are available for each manipulator model.

Example

Following is an example of a weight specification in a procedure:

	Action	Note
	 CAUTION The arm weighs 25 kg. All lifting accessories used must be sized accordingly.	

7 Reference information

7.6 Standard tools

7.6 Standard tools

General

All service (repairs, maintenance, and installation) procedures contains lists of tools required to perform the specified activity.

All special tools required are listed directly in the procedures while all the tools that are considered standard are gathered in the standard toolkit and defined in the following table.

This way, the tools required are the sum of the standard toolkit and any tools listed in the instruction.

Contents, standard toolkit

Qty	Tool	Rem.
1	Ring-open-end spanner 8-19 mm	
1	Socket head cap 5-17 mm	
1	Torx socket no: 20-60	
1	Box spanner set	
1	Torque wrench 10-100 Nm	
1	Torque wrench 75-800 Nm	
1	Ratchet head for torque wrench 1/2	
2	Hexagon-headed screw M10x100	
1	Hexagon-headed screw M16x90	
1	Hex bit socket head cap no. 14 socket 40 mm L=100 mm	
1	Hex bit socket head cap no. 14 socket 40 mm L=20 mm	To be shortened to 12 mm
1	Hex bit socket head cap no. 6 socket 40 mm L=145 mm	
1	Hex bit socket head cap no. 6 socket 40mm bit L=220 mm	
1	Multigrip plier	
1	Plastic mallet	

7.7 Special tools

General

All service instructions contain lists of tools required to perform the specified activity. The required tools are a sum of standard tools, defined in the section [Standard tools on page 398](#), and of special tools, listed directly in the instructions and also gathered in this section.

Calibration equipment, Axis Calibration

The following table specifies the calibration equipment needed when calibrating the robot with the Axis Calibration method.

Description	Art. no.	Note
Calibration tool box, Axis Calibration	3HAC074119-001	Delivered as a set of calibration tools. Required if Axis Calibration is the valid calibration method for the robot.

Special tools

This table specifies the special tools required during several of the service procedures. The tools are specified directly in concerned instructions.

Description	Qty	Article no.
Guide pins M12x130	2	3HAC022637-001
Guide pins M10x150	2	3HAC13120-2
Guide pins M10x140 (Used with one of the M10x150 guide pins when replacing the axis 2 and 3 gear-boxes)	1	-
Lifting eye M12	2	3HAC025333-005
Adapter (used with lifting eye M12)	2	3HAC040381-001
Shackle, lifting capacity 1,000 kg (Used with lifting eye M12)	2	-
Lifting eye bolt, M20	2	-
Shackle, lifting capacity 2,000 kg (Used with lifting eye bolt M20)	2	-
Crank	1	-
Press tool, premounting outer race bearing	1	3HAC077982-001

Continues on next page

7 Reference information

7.7 Special tools

Continued

Description	Qty	Article no.
Press tool, replacing shaft tilthouse The tool consists of: <ul style="list-style-type: none"> • 3HAC040029-002 Pressing tool bearing • 3HAC040029-003 Pressing tool bearing • 3HAC040021-004 Pressing tool • 3HAC040021-005 Hollow cylinder RCH 123 • 3HAC040022-004 Threaded bar M16 length 450 mm (removal). For refitting length 350 mm. 	1	3HAC040029-001
Auxiliary shaft Used together with press tool 3HAC040029-001 (only when removing).	1	3HAC040035-001
KM7 socket	1	3HAC040025-001
Adapter	1	3HAC040027-001
Press tool, support ring	1	3HAC072616-001
Press tool, upper arm The tool is also used as Pull tool. <i>Difference</i> : Press bushing is used instead of support bushing. The tool consists of: <ul style="list-style-type: none"> • 3HAC040026-003 Press bushing • 3HAC040026-002 Pressing tool upper arm • 3HAC040021-004 Thread washer • 3HAC040021-005 Hollow cylinder RCH 123 • 3HAC040022-004 Threaded bar M16 length 350 mm. 	1	3HAC040026-001
Pull tool, upper arm The tool is also used as Press tool. <i>Difference</i> : Support bushing is used instead of Press bushing. The tool consists of: <ul style="list-style-type: none"> • 3HAC040026-004 Support bushing • 3HAC040026-002 Pressing tool upper arm • 3HAC040021-004 Thread washer • 3HAC040021-005 Hollow cylinder RCH 123 • 3HAC040022-004 Threaded bar M16 length 350 mm. 	1	3HAC040026-001
KM12 socket	1	3HAC040023-001
Auxiliary shaft	1	3HAC040022-002
Press tool link, bearing outer races	1	3HAC077981-001
Lower part of pressing tool	1	3HAC040031-001

Continues on next page

Description	Qty	Article no.
Press tool, link The tool consists of: <ul style="list-style-type: none"> • 3HAC040022-002 Pressing tool • 3HAC040022-003 Pressing tool • 3HAC040021-004 Pressing tool • 3HAC040021-005 Hollow cylinder RCH 123 • 3HAC040022-004 Threaded bar M16 length 350 mm. 	1	3HAC040022-001
KM8 socket	1	3HAC040024-001
Mounting/Demounting tool (Parallel rod) The tool consists of: <ul style="list-style-type: none"> • 3HAC040021-004 Pressing tool • 3HAC040021-002 Pressing tool • 3HAC040021-003 Pressing tool • 3HAC040021-005 Hollow cylinder RCH 123 • 3HAC040021-006 Threaded bar M16 length 530 mm. 	1	3HAC040021-001
Shims thickness 8 mm	1	-
Rotation tool	1	-
Screw M12x100 Fully threaded	2	-
Screw M12x60 Fully threaded	2	-
Bits extension	1	3HAC12342-1
Bits holder Stahlwille 736/40 D10 (or similar)	1	-
Lifting accessory, motor axes 2-3	1	3HAC15534-1
Support, base and gear ax 1	1	3HAC15535-1
Lifting accessory, base and gear ax 1	1	3HAC15556-1
Lifting accessory	1	3HAC025214-001
Oil collecting vessel capacity 8,000 ml	1	-
Oil exchange equipment	1	3HAC021745-001

7 Reference information

7.8 Lifting accessories and lifting instructions

7.8 Lifting accessories and lifting instructions

General

Many repair and maintenance activities require different pieces of lifting accessories, which are specified in each procedure.

The use of each piece of lifting accessories is *not* detailed in the activity procedure, but in the instruction delivered with each piece of lifting accessories.

The instructions delivered with the lifting accessories should be stored for later reference.

8 Spare parts

8.1 Spare part lists and illustrations

Location

Spare parts and exploded views are not included in the manual but delivered as a separate document for registered users on myABB Business Portal, www.abb.com/myABB.



Tip

All documents can be found via myABB Business Portal, www.abb.com/myABB.

This page is intentionally left blank

9 Circuit diagrams

9.1 Circuit diagrams

Overview

The circuit diagrams are not included in this manual, but are available for registered users on myABB Business Portal, www.abb.com/myABB.

See the article numbers in the tables below.

Controllers

Product	Article numbers for circuit diagrams
<i>Circuit diagram - IRC5</i>	3HAC024480-011
<i>Circuit diagram - IRC5 Compact</i>	3HAC049406-003
<i>Circuit diagram - IRC5 Panel Mounted Controller</i>	3HAC026871-020

Manipulators

Product	Article numbers for circuit diagrams
<i>Circuit diagram - IRB 120</i>	3HAC031408-003
<i>Circuit diagram - IRB 140 type C</i>	3HAC6816-3
<i>Circuit diagram - IRB 260</i>	3HAC025611-001
<i>Circuit diagram - IRB 360</i>	3HAC028647-009
<i>Circuit diagram - IRB 390</i>	3HAC060545-009
<i>Circuit diagram - IRB 460</i>	3HAC036446-005
<i>Circuit diagram - IRB 660</i>	3HAC025691-001
<i>Circuit diagram - IRB 760</i>	3HAC025691-001
<i>Circuit diagram - IRB 1200</i>	3HAC046307-003
<i>Circuit diagram - IRB 1410</i>	3HAC2800-3
<i>Circuit diagram - IRB 1600/1660</i>	3HAC021351-003
<i>Circuit diagram - IRB 1520</i>	3HAC039498-007
<i>Circuit diagram - IRB 2400</i>	3HAC6670-3
<i>Circuit diagram - IRB 2600</i>	3HAC029570-007
<i>Circuit diagram - IRB 4400/4450S</i>	3HAC9821-1
<i>Circuit diagram - IRB 4600</i>	3HAC029038-003
<i>Circuit diagram - IRB 6620</i>	3HAC025090-001
<i>Circuit diagram - IRB 6620 / IRB 6620LX</i>	3HAC025090-001
<i>Circuit diagram - IRB 6640</i>	3HAC025744-001
<i>Circuit diagram - IRB 6650S</i>	3HAC13347-1 3HAC025744-001

Continues on next page

9 Circuit diagrams

9.1 Circuit diagrams

Continued

Product	Article numbers for circuit diagrams
<i>Circuit diagram - IRB 6660</i>	<i>3HAC025744-001 3HAC029940-001</i>
<i>Circuit diagram - IRB 6700 / IRB 6790</i>	<i>3HAC043446-005</i>
<i>Circuit diagram - IRB 7600</i>	<i>3HAC13347-1 3HAC025744-001</i>
<i>Circuit diagram - IRB 14000</i>	<i>3HAC050778-003</i>
<i>Circuit diagram - IRB 910SC</i>	<i>3HAC056159-002</i>

Index

A

additional mechanical stop location, 117
 allergenic material, 30
 aluminum
 disposal, 388
 ambient humidity
 operation, 45
 storage, 45
 ambient temperature
 operation, 45
 storage, 45
 assembly instructions, 41
 assessment of hazards and risks, 30
 Axis Calibration, 370
 calibration tool
 article number, 373, 377
 examining, 373
 installation position, 375
 overview of method, 370
 procedure on FlexPendant, 377
 protective cover and protection plug, 375, 377

B

base plate
 guide pins, 63
 securing, 63
 batteries
 disposal, 388
 battery
 replacing, 134, 178
 battery pack
 replacing, interval, 102
 battery shutdown
 service routine, 134, 178
 brake release, 60
 brake release board, replacement, 183
 brakes
 testing function, 38
 buttons for brake release, 60

C

cabinet lock, 31
 cable harness attachments, 111
 cabling, robot, 92
 cabling between robot and controller, 92
 calibrating
 robot, 370
 roughly, 364, 368
 calibrating robot, 370
 calibration
 rough, 364, 368
 standard type, 360
 verification, 383
 when to calibrate, 361
 calibration manuals, 360
 calibration marks, 362
 calibration position
 jogging to, 384–385
 scales, 362
 calibration scales, 362
 carbon dioxide extinguisher, 31
 cast iron
 disposal, 388
 changing oil

axis 1, 124
 axis 2, 128
 axis 3, 128
 axis 6, 132
 cleaning, 138
 climbing on robot, 34
 Cold environments, 91
 connecting the robot and controller, cabling, 92
 copper
 disposal, 388

D

damage to additional mechanical stop, 117
 damage to mechanical stop, 115
 dampers, 119
 dimensions
 turning disk, 74
 upper arm, 72
 direction of axes, 363

E

environmental information, 388
 equipment on robot, 72
 ESD
 damage elimination, 51
 sensitive equipment, 51
 extra equipment
 robot, 72
 turning disk, 74
 upper arm, 72

F

fire extinguishing, 31
 fitting equipment on robot, 72
 fitting fork lift, 52
 FlexPendant
 jogging to calibration position, 384–385
 MoveAbsJ instruction, 384–385
 updating revolution counters, 365, 368
 fork lift, 55
 foundation
 requirements, 45

G

gearbox
 oil change axis 1, 124
 oil change axis 2, 128
 oil change axis 3, 128
 oil change axis 6, 132
 gearbox axis 1, replacement, 328
 gearboxes
 location of, 123
 grease, 34
 disposal, 388
 guide pins, base plate, 63

H

hanging
 installed hanging, 30
 hazard levels, 21
 hazardous material, 388
 height
 installed at a height, 30
 hot surfaces, 34
 HRA, 30
 humidity
 operation, 45

storage, 45

I

information labels location, 113

inspecting

additional mechanical stop, 117

cable harness, 111

information labels, 113

mechanical stop, 115

inspecting oil levels

axes 2-3, 106

axis-1, 104

axis 6, 109

inspection

dampers, 119

installation

mechanical stop axis 1, 89

installing equipment on robot, 72

instructions for assembly, 41

integrator responsibility, 30

intervals for maintenance, 101

L

labels

robot, 23

lamp unit

installing, 87

leak-down test, 142

lifting accessory, 397

lifting robot

with fork lift, 55

with roundslings, 58

limitation of liability, 19

linkage

replacing lower rod, 248

replacing upper rod, 240

Lithium

disposal, 388

loads on foundation, 44

lock and tag, 31

lubricants, 34

lubrication

amount in gearboxes, 123

type of lubrication, 123

M

maintenance schedule, 101

manually releasing brakes, 60

mechanical stop

axis 1, 89

mechanical stop location, 115

MoveAbsJ instruction, 384–385

N

national regulations, 30

negative directions, axes, 363

neodymium

disposal, 388

nodular iron

disposal, 388

O

oil, 34

amount in gearboxes, 123

disposal, 388

type of oil, 123

oil change

axis 1, 124

axis 2, 128

axis 3, 128

axis 6, 132

oil level

gearbox axes 2-3, 106

gearbox axis-1, 104

gearbox axis 6, 109

operating conditions, 45

option

signal lamp, 83, 87

original spare parts, 19

P

pedestal

installed on pedestal, 30

personnel

requirements, 20

plastic

disposal, 388

positive directions, axes, 363

PPE, 20

product standards, 392

protection classes, 46

protection type, 46

protective equipment, 20

protective wear, 20

R

recycling, 388

regional regulations, 30

release brakes, 37

replacement

brake release board, 183

gearbox axis 1, 328

turning disk, 196

replacements, report, 141

replacing

lower rod, linkage, 248

upper rod, linkage, 240

xx, 95

report replacements, 141

requirements on foundation, 45

responsibility and validity, 19

restricting

working range axis 1, 89

revolution counters

storing on FlexPendant, 365, 368

updating, 364, 368

risk of burns, 34

risk of tipping, 49

robot

labels, 23

protection class, 46

protection types, 46

symbols, 23

rubber

disposal, 388

S

safety

brake testing, 38

ESD, 51

fire extinguishing, 31

release robot axes, 37

signals, 21

signals in manual, 21

- symbols, 21
 - symbols on robot, 23
 - test run, 97
 - safety devices, 31
 - safety equipment
 - mechanical stop, 89
 - signal lamp, 121
 - safety hazard
 - hydraulic system, 32
 - pneumatic system, 32
 - safety signals
 - in manual, 21
 - safety standards, 392
 - scales on robot, 362
 - schedule for maintenance, 101
 - screw joints, 394
 - securing
 - base plate, 63
 - securing, robot, 68
 - securing the robot to foundation, attachment screws, 68
 - shipping, 387
 - signal lamp
 - installing, 87
 - signal lamp, installation, 83
 - signals
 - safety, 21
 - SMB
 - replacing, 178
 - SMB battery
 - extension of lifetime, 134, 178
 - replacing, 134, 178
 - special tools, 399
 - speed
 - adjusting, 91
 - stability, 49
 - standards, 392
 - ANSI, 392
 - CAN, 392
 - start of robot in cold environments, 91
 - steel
 - disposal, 388
 - storage conditions, 45
 - symbols
 - safety, 21
 - synchronization position, 364, 368
 - sync marks, 362
 - system integrator requirements, 30
-
- T**
 - temperatures
 - operation, 45
 - storage, 45
 - testing
 - brakes, 38
 - tools
 - Axis Calibration, 399
 - for service, 399
 - torques on foundation, 44
 - transportation, 387
 - troubleshooting
 - oil spills, 138
 - safety, 39
 - turning disk dimensions, 74
 - turning disk replacement, 196
-
- U**
 - UL lamp, installation, 83
 - upcycling, 388
 - updating revolution counters, 364, 368
 - upper arm
 - dimensions, 72
 - users
 - requirements, 20
-
- V**
 - validity and responsibility, 19
 - velocity
 - adjusting, 91
 - verifying calibration, 383
-
- W**
 - weight, 43
 - base plate, 62, 67
 - robot, 57–58, 190, 193, 215, 218, 229, 233, 286, 289, 295–296, 299, 305–306, 314, 316, 331–332, 334–335, 340, 342, 348, 350
 - working range, 47
 - restricting axis 1, 89
-
- X**
 - xx
 - replacing, 95
-
- Z**
 - zero position
 - checking, 384



ABB AB

Robotics & Discrete Automation

S-721 68 VÄSTERÅS, Sweden

Telephone +46 10-732 50 00

ABB AS

Robotics & Discrete Automation

Nordlysvegen 7, N-4340 BRYNE, Norway

Box 265, N-4349 BRYNE, Norway

Telephone: +47 22 87 2000

ABB Engineering (Shanghai) Ltd.

Robotics & Discrete Automation

No. 4528 Kangxin Highway

PuDong New District

SHANGHAI 201319, China

Telephone: +86 21 6105 6666

ABB Inc.

Robotics & Discrete Automation

1250 Brown Road

Auburn Hills, MI 48326

USA

Telephone: +1 248 391 9000

abb.com/robotics